



Caprari è un gruppo industriale specializzato nella progettazione, produzione ed assistenza di Pompe ed Elettropompe centrifughe e soluzioni avanzate per la gestione del ciclo integrato dell'acqua. Dalla captazione nei pozzi profondi al sollevamento e trattamento delle acque reflue e di drenaggio, dall'alimentazione e distribuzione idrica nei settori civile, industriale ed agricolo, alle più svariate applicazioni nella movimentazione delle acque, Caprari è in grado di fornire le migliori e più efficienti soluzioni grazie al suo consolidato know-how specialistico.

Caprari is an industrial group dedicated to the design, manufacture and servicing of centrifugal Pumps, Electric-Pumps and advanced solutions for managing the integrated water cycle. Thanks to its strong specialized know-how, Caprari is able to supply the best and most efficient solutions from extraction in deep wells to the lifting and treatment of waste and drainage waters; from the supply and distribution in civil, industrial and agricultural sectors to a large number of specific applications in water conveyance.

Caprari est un groupe industriel spécialisé dans la conception, la production et l'assistance de pompes et d'électropompes centrifuges et de solutions avancées pour la gestion du cycle intégré de l'eau. Du captage dans les puits profonds à l'élevation et traitement des eaux usées et de drainage, de l'alimentation et distribution hydrique dans les secteurs privé, industriel et agricole, aux applications les plus diverses dans le transfert des eaux, Caprari est en mesure de fournir les solutions les meilleures et les plus efficaces grâce à son savoir-faire spécialisé consolidé.

Acquedottistica
Trattamento acque, depurazione, fognature
Irrigazione agricola

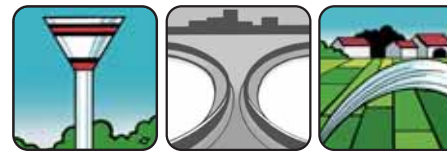

Aqueducts
Water treatment
Agricultural irrigation

Adduction d'eau
Traitement d'eau, station d'épuration
Irrigation

Serre e giardinaggio
Applicazioni industriali
Antincendio

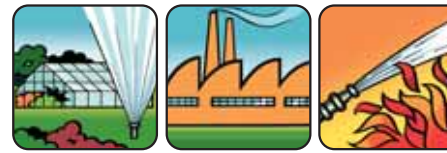

Market gardens, landscaping
Industrial applications
Fire Fighting

Serres et jardins
Installations Industrielles
Lutte anti-incendie

Alimentazione idrica ad uso civile
Impianti per il tempo libero
Allevamenti



Domestic water supply
Leisure parks
Stock-farming

Alimentation d'eau potable
Installation des bases de loisirs
Elevage

Drenaggio
Innevamento artificiale
Lavaggio industriale

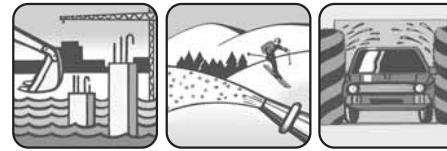

Site drainage
Artificial snow
Service stations

Drainage
Enneigement artificiel
Lavage industriel

Condizionamento ad uso civile
Bonifiche
Arredo urbano

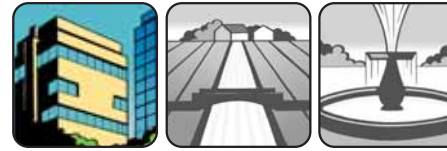

Civil Engineering
Land reclamation
Fountains

Climatisation
Drainage des marais
Fontainerie

caprari

COMPANY
WITH QUALITY SYSTEM
CERTIFIED BY DNV
= ISO 9001/2000 =

CAPRARI S.p.A. - VIA EMILIA OVEST 900 - 41100 - MODENA (ITALY)
Tel. +39 059 897611 - Fax +39 059 897897 - e-mail: info@caprari.it

www.caprari.com

BOMBAS CAPRARI S.A., ALCALÁ DE HENARES - MADRID (ESPAÑA) • CAPRARI FRANCE S.A.R.L., MAUREPAS - PARIS (FRANCE)
CAPRARI PORTUGAL LDA SANTARÉM (PORTUGAL) • CAPRARI PUMPEN GMBH, FÜRTH/BAY (DEUTSCHLAND) • CAPRARI HELLAS S.A., THESSALONIKI (GREECE)
CAPRARI PUMPS (U.K.) LTD., PETERBOROUGH (UNITED KINGDOM) • CAPRARI PUMPS AUSTRALIA PTY LTD., BEVERLY SA (AUSTRALIA)
SWM S.p.A. Submersible motors, RUBIERA - REGGIO EMILIA (ITALY) • FONDMATIC S.p.A. Foundry, CREVALCOORE - BOLOGNA (ITALY)

POMPE CENTRIFUGHE PLURISTADIO AD ASSE ORIZZONTALE
MULTISTAGE CENTRIFUGAL PUMPS WITH HORIZONTAL SHAFT
POMPES CENTRIFUGES MULTICELLULAIRES A AXE HORIZONTAL

Serie - Series - Série

HMU

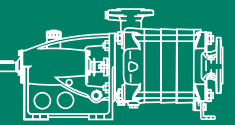

caprari
pumping power

Massima convenienza e prestazioni costanti nel tempo

Maximum convenience and constant performances over time

Le meilleur choix et la fiabilité des performances dans le temps

Le pompe della serie HMU sono pompe centrifughe multistadio ad asse orizzontale, a semplice aspirazione, dotate di un supporto a sedia ampiamente dimensionato che assicura una grande rigidità alla macchina, indispensabile per l'accoppiamento ai motori termici.

Queste pompe sono frutto di una lunga esperienza di progettazione, costruzione ed applicazione ai più diversi settori di impiego quali l'approvvigionamento idrico per uso acquedottistico, industriale, irriguo, antincendio, ed ogni più generale servizio di trasporto d'acqua dolce.

L'estensione della gamma di produzione, la possibilità di accoppiamento diretto a motori elettrici e termici, la disponibilità di esecuzioni speciali su richiesta permettono di proporre, per ogni diverso utilizzo, la soluzione ottimale dal punto di vista dell'affidabilità, del rendimento e, conseguentemente, dell'economia di esercizio.

Pompe adatte per il pompaggio di acqua dolce, pulita, chimicamente e meccanicamente non aggressiva.



Groupo elettropompa su base per installazione fissa
Electric pumping set - fixed installation
Groupe électropompe sur chassis pour installation fixe



Groupo motopompa per installazione mobile
Engine driven pumping set - mobile installation
Groupe motopompe pour installation mobile

The HMU series are multistage centrifugal pumps, horizontal, single suction, fitted with a heavy duty pedestal which gives to the machine the high rigidity necessary for coupling it to combustion engines.

These pumps are the outcome of a large experience acquired both in designing and manufacturing as well as in the most common application such as public and industrial water supply, fire fighting, irrigation and any fresh water handling.

The extended model range, the possibility of direct coupling to electric motors or to combustion engines, the availability of special constructions on demand are enabling offers for each of the different applications, the best solution for dependability, efficiency and energy saving.

Pumps suitable for clean, chemically and mechanically non-aggressive waters.

Les pompes de la série HMU sont des pompes centrifuges multicellulaires à axe horizontal, à aspiration axiale, montées sur chaise-palier largement dimensionné, assurant la rigidité indispensable pour l'accouplement aux moteurs à combustion interne.

Ces pompes sont le résultat d'une longue expérience dans le projet, la fabrication et l'application dans différents secteurs tels que l'adduction d'eau pour usage civil et industriel, lutte anti-incendie, irrigation, et tout service de pompage de l'eau.

L'étendue de la gamme de production, la possibilité d'accouplement direct à des moteurs électriques ou à combustion interne, la disponibilité de constructions spéciales sur demande, permettent de proposer, pour toute utilisation différente, la meilleure solution en tant que fiabilité, rendement et économie d'énergie.

Les pompes sont adaptées au pompage d'eaux douces, claires, chimiquement et mécaniquement non agressives.

COSTRUZIONE STANDARD

- Corpo mandata con bocca premente flangiata, posta in posizione radiale rivolta normalmente verso l'alto.
- Stadio intermedio costituito da mantello esterno e relativo diffusore palettato, girante radiale con dispositivo di compensazione della spinta assiale.
- Coperchio aspirazione con bocca aspirante flangiata in posizione assiale.
- Tiranti per il serraggio dei corpi intermedi fra quelli di aspirazione e mandata.
- Supporto a sedia, ampiamente dimensionato; funge da base di appoggio e, nel contempo, sostiene a sbalzo la parte idraulica.
- Albero: guidato e sostenuto da due cuscinetti a sfere alloggiati nel supporto a sedia e lubrificati con olio; essi sono largamente dimensionati a permettere l'accoppiamento sia a motore elettrico che endotermico a mezzo di giunto elastico.
- Tenuta a baderna registrabile, facilmente ricambiabile, alloggiata nella camera stoppa ricavata nel corpo mandata.
- Senso di rotazione: orario visto dal lato comando.

STANDARD CONSTRUCTION

- Pump casing with top directed radially positioned flanged delivery outlet.
- Intermediate bowl composed by an external casing protecting a guide blade diffuser, radial impeller with axial thrust compensation.
- Suction cover with flanged suction inlet axially positioned.
- Tie-rods for tightening up the intermediate bowls between suction cover and volute.
- Support bearing stand, amply sized; serves as a base and support of the overhanged wet end.
- Shaft: guided and supported by two oil lubricated ball bearings housed in the bearing stand support. Bearings are amply sized for coupling to electric motors and endothermic engines by means of flexible coupling.
- Seals usually adjustable packing, easily replaceable, housed in the delivery casing's packing gland chamber.
- Direction of rotation: clockwise viewed from drive side.

CONSTRUCTION STANDARD

- Corps de pompe avec tubulure de refoulement à bride, placé en position radiale et orientée normalement vers le haut.
- Etages intermédiaires composés par corps et diffuseurs renforcés de pièces, roues radiales avec dispositif pour la compensation de la poussée axiale.
- Couvercle d'aspiration avec la tubulure d'aspiration à bride en position axial.
- Tirants pour le serrage des corps intermédiaires entre le corps d'aspiration et le corps de refoulement.
- Palier largement dimensionné et faisant fonction d'appui pour la fixation de l'ensemble et sur lequel la partie hydraulique est montée en porte-à faux.
- Arbre: guidé et soutenu par deux roulements à billes logés dans le support et lubrifiés à l'huile. Ils sont largement dimensionnés pour permettre l'entraînement par moteur électrique ou thermique par l'intermédiaire d'un accouplement élastique.
- Garniture à tresse facilement remplaçable logée dans une chambre du corps de refoulement.
- Sens de rotation: horaire vu côté entraînement.

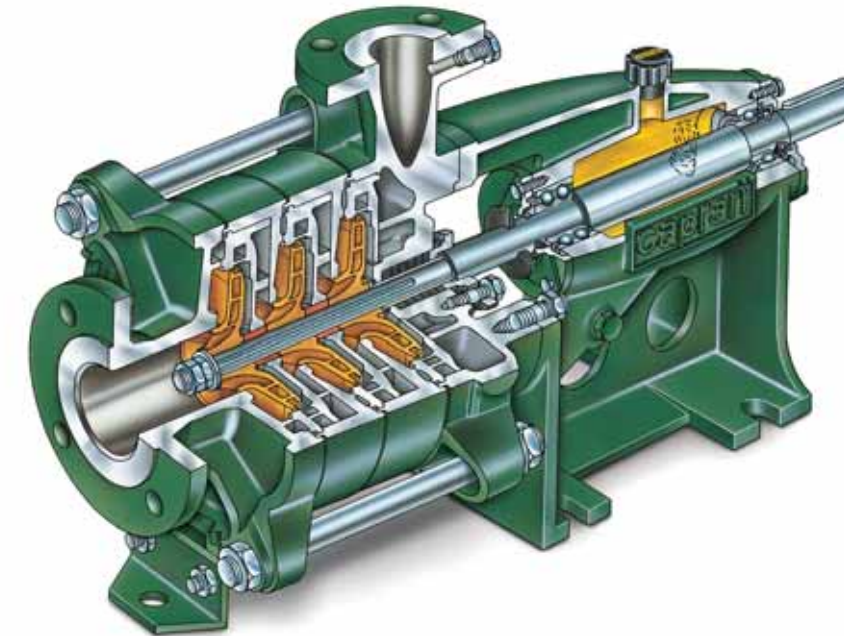

Materiali pompa - Pump materials - Matériaux pompe

- | | | |
|--|--|---|
| <ul style="list-style-type: none"> - CORPO MANDATA
Ghisa grigia
Cast iron - SUPPORTO ASPIRAZIONE
Ghisa grigia
Cast iron - GIRANTE
Cuprollega
Copperalloy - DIFFUSORE
Ghisa grigia
Cast iron - MANTELLO
Ghisa grigia
Cast iron - ALBERO POMPA
Acciaio inox
Stainless Steel - BUSSOLA ALBERO
Acciaio inox
Stainless Steel - PREMITRECCIA
Ghisa grigia
Cast iron - BADERNA
Trezza grafitata
Graphited cord - CUSCINETTI A SFERE
Acciaio
Steel - SUPPORTO A SEDIA
Ghisa grigia
Cast iron - PIEDE DI SOSTEGNO
Acciaio
Steel - TIRANTI
Acciaio
Steel - Prigionieri e dadi premitreccia
in acciaio inox.
Stainless Steel - ▲ BRONZINA
Bronzo
Bronze - ▲ BUSSOLA ALBERO
Acciaio inox
Stainless Steel - ● TENUTA MECCANICA
Acciaio/grafite
Steel/graphite - ● FLANGIA PORTA TENUTA
MECCANICA
MECCANICA
Ghisa grigia
Cast iron | <ul style="list-style-type: none"> - DELIVERY CASING
Cast iron - SUCTION CASING
Cast iron - IMPELLER
Copperalloy - DIFFUSER
Cast iron - SHELL
Cast iron - PUMP SHAFT
Stainless Steel - SHAFT BUSH
Stainless Steel - STUFFING BOX
Cast iron - PACKING
Graphited cord - BALL BEARINGS
Steel - PEDESTAL
Cast iron - DUCK FOOT PEDESTAL
Steel - TIE BOLTS
Steel - Studs and nuts of packing
gland in stainless steel.
Stainless Steel - ▲ BEARING BUSH
Bronze - ▲ SHAFT BUSH
Stainless Steel - ● MECHANICAL SEAL
Steel/graphite - ● MECHANICAL SEAL
COLLAR
Cast iron | <ul style="list-style-type: none"> - CORPS DE REFOULEMENT
Fonte grise
Cast iron - SUPPORT D'ASPIRATION
Fonte grise
Cast iron - ROUE
Alliage de cuivre
Copper alloy - DIFFUSEUR
Fonte grise
Cast iron - MANTEAU
Fonte grise
Cast iron - ARBRE DE POMPE
Acier inox
Stainless Steel - DOUILLE ARBRE
Acier inox
Stainless Steel - PRESSE-ETOUPPE
Fonte grise
Cast iron - ETOUPE
Tresse graphitée
Graphite/cord - ROULEMENTS A BILLES
Acier
Steel - CHAISE-PALIER
Fonte grise
Cast iron - PIED DE SOUTIEN
Acier
Steel - TIRANTS
Acier
Steel - Écrous du presse-étoupe en
Acier inox
Stainless Steel - ▲ COUSSINET
Bronze - ▲ DOUILLE ARBRE
Acier inox
Stainless Steel - ● GARNITURE MECANIQUE
Graphite/acier
Steel/graphite - ● BRIDE ETANCHEITE
MECANIQUE
MECANIQUE
Fonte grise
Cast iron |
|--|--|---|

- ▲ Solo per - Suitable for - Nur für: HMU-HMUT40-1/7*8 - HMU-HMUT40-2/7*8 - HMU-HMUT50-1/6*8 - HMU-HMUT50-2/6*8
- Versione HMUT - HMUT version - Version HMUT

Campi di prestazioni - Performance ranges
Champ de performances

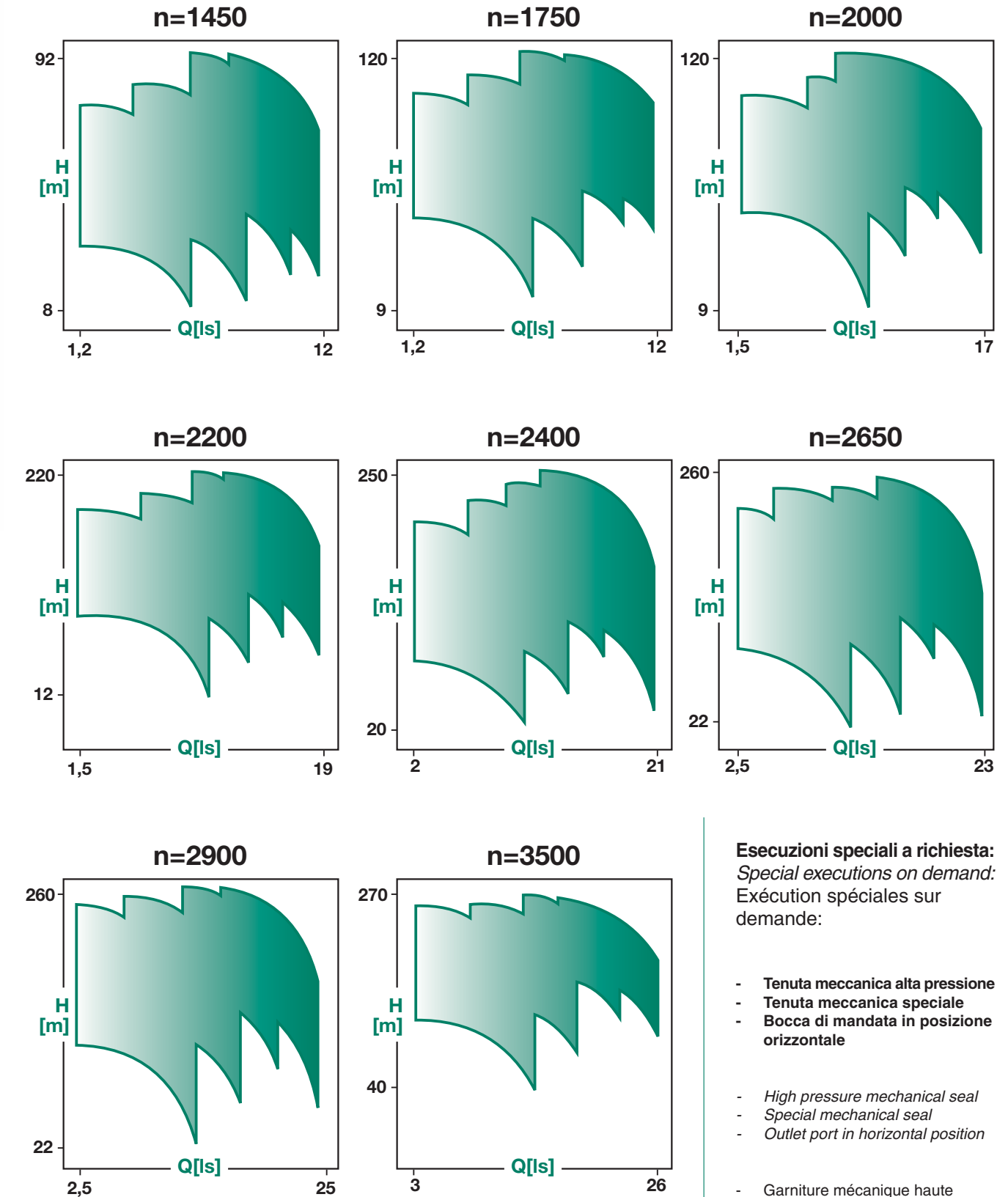

Per caratteristiche di funzionamento e dati tecnici consultare la documentazione di vendita
For performances and technical data refer to sale literature.
Pour performances et données techniques voir documentation de vente.

Esecuzioni speciali a richiesta:
Special executions on demand:
Exécution spéciales sur demande:

- Tenuta meccanica alta pressione
- Tenuta meccanica speciale
- Bocca di mandata in posizione orizzontale
- High pressure mechanical seal
- Special mechanical seal
- Outlet port in horizontal position
- Garniture mécanique haute pression
- Garniture mécanique spéciale
- Orifice de refoulement en position horizontale