

## FBM Tank Bottom Mixer

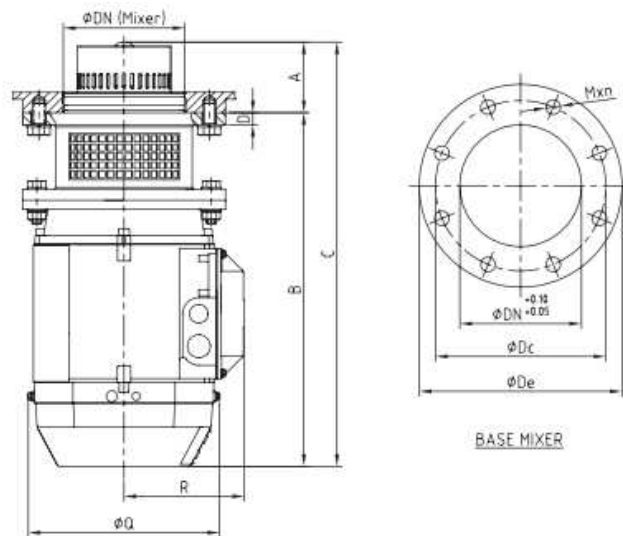

FBM series of the high shear bottom of the tank mixers present a highly hygienic solution for the processes of dispersion, emulsifying, homogenisation and disintegration of solids in the food-processing, cosmetics, pharmaceutical and fine chemistry industries. These mixers can be used either in open or closed tanks at atmospheric pressure or under pressure/vacuum. The bottom of the tank mixers are designed for the applications of the highly viscous media and intended for work with anchor type agitators.

Type	Motor	A	B	C	D	Q	R	Flange Dimensions			
								ØDe	ØDc	ØDn	M*n
FBM-30-022	2,2 kw 3000 rpm	82	355	437	18	180	122	200	160	131,5	M16*4
FBM-30-040	4 kw 3000 rpm	87	436	523	15	236	148	250	210	150	M16*8
FBM-30-075	7,5 kw 3000 rpm		492	579		261	163			150	
FBM-30-185	18,5 kw 3000 rpm	108	656	764	26	310	208	330	300	175	
FBM15-220	22 kw 1500 rpm	144	730	838		349	223		300	175	



Type	Viscosity		Additional agitation
	1 cpu	3000 cpu	
FBM-30-022	300L	100L	300L
FBM-30-040	750L	300L	750L
FBM-30-075	1500L	750L	1500L
FBM-30-185	2000L	1000L	2000L
FBM15-220	2500L	1500L	2500L

