

**FAV / FAP VERTICAL & PORTABLE AGITATOR**

**DIMENSIONS**

TYPE	Ø DN	ØA	ØB	E	ØG (n)	Ød	L Max	Cmax	H
FAV 15-007-130	30	160	130	130	10,54 (4)	16	1250	360	130
FAV 10-005-130	30	160	130	130	10,54 (4)	16	1250	360	130

**CAPACITY**

Capacity (m³)	Power (kw)	Speed (rpm)	Weight (kg)
0,8	0,75	1500	16,5
0,7	0,55	900	17



**FAV**

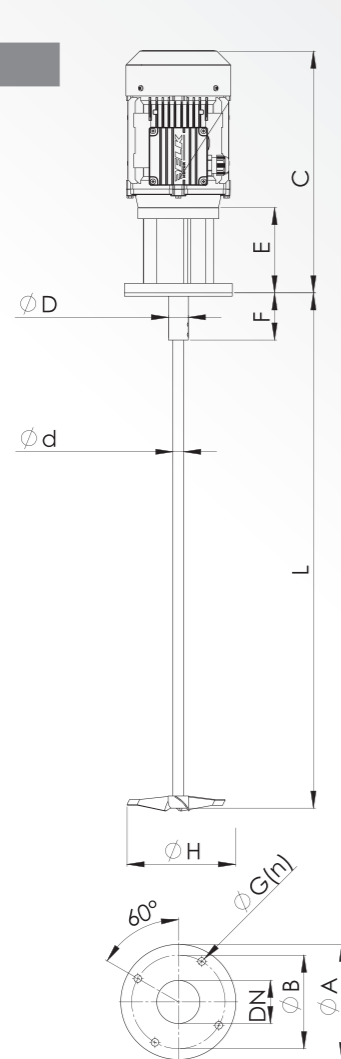

**FAP**

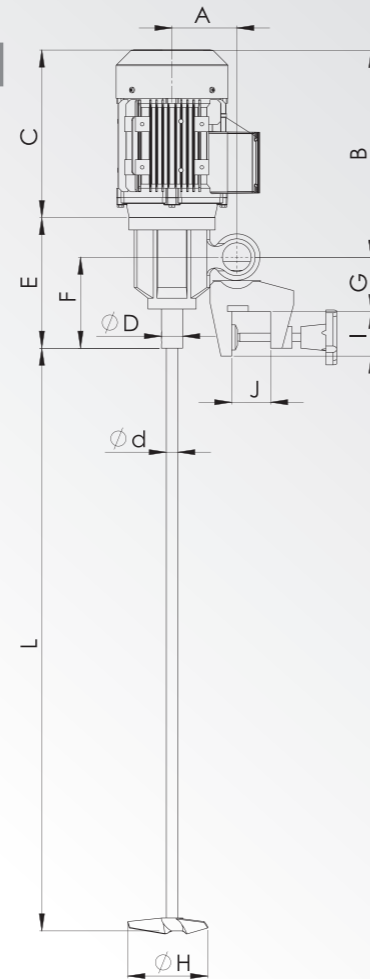

**FAV / FAP  
VERTICAL & PORTABLE  
AGITATOR**

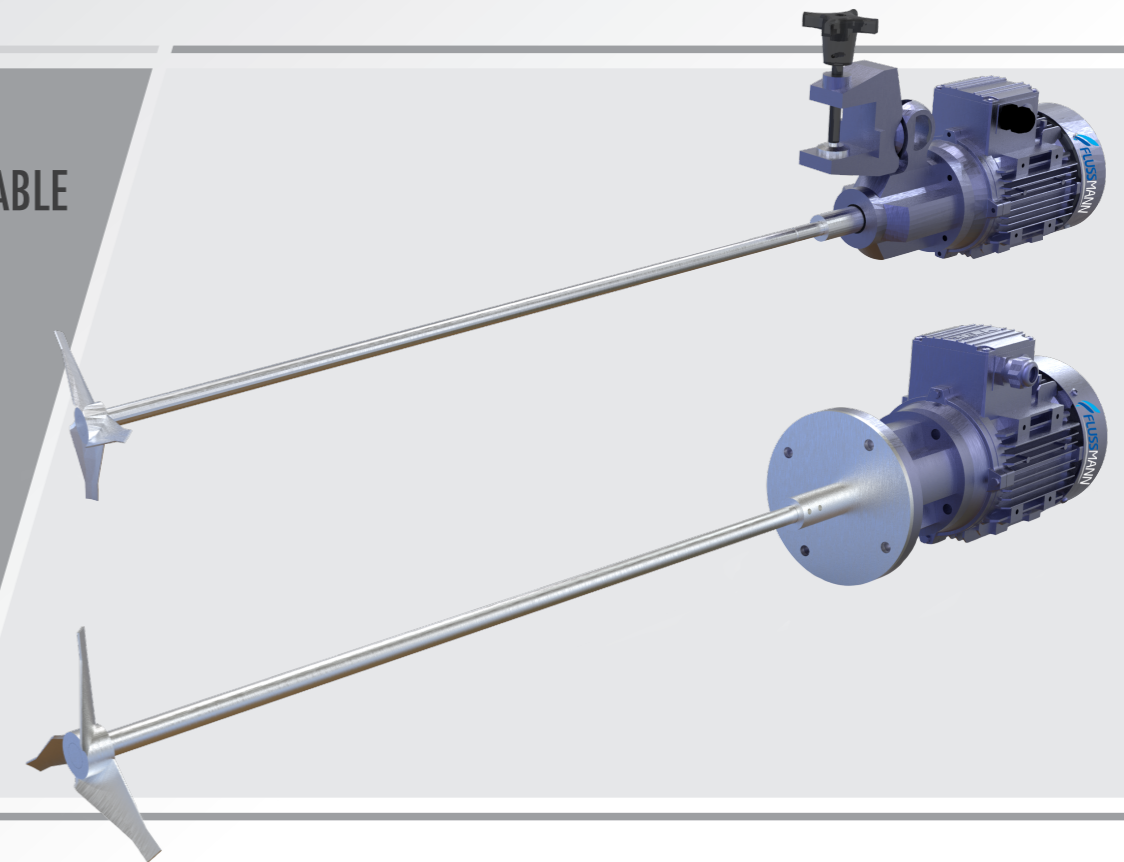

**DIMENSIONS**

Type	A	B	E	F	Ød	L max	Cmax	H	
FAP 15-007-130	30	90	290	180	124	16	1250	234	130
FAP 10-005-130	30	90	290	180	124	16	1250	234	130

**CAPACITY**

Capacity (m³)	Power (kw)	Speed (rpm)	Weight (kg)
0,8	0,75	1500	16
0,7	0,55	900	16,5

**YOUR SOLUTION PARTNER**



## FAP PORTABLE AGITATOR

### APPLICATION

- » FAP series agitators are vertical direct motor-driven agitators with clamp.
- » High-speed agitation is used in the food processing, cosmetics, pharmaceutical or chemical industries.

### WORKING PRINCIPLE

- » These agitators are fixed to the wall of the tank by means of a clamp
- » Thanks to the joint, they can be inclined to the use position.
- » The rotation of the propeller makes the fluid flow to the bottom of the tank and then up to the surface of the fluid along the tank wall opposite to the wall to which the agitator is fitted.
- » This effect is promoted if the bottom of the tank is curved.

### DESIGN AND FEATURES

- » Agitator with clamp.
- » Bearing support.
- » IEC B14 motors, 1500 rpm, IP 55, F-class insulation.
- » Maximum power 0,75 kW.
- » Lineflux propeller

### MATERIALS

- » Parts in contact with the media : AISI 316L
- » Retainer : NBR
- » Bearing support : Aluminum

### OPTIONS

- » Motor cover
- » Atex motor
- » Motors: 1000 rpm or 1500 rpm
- » Geared motors or variable speed drives
- » Saw tooth impeller

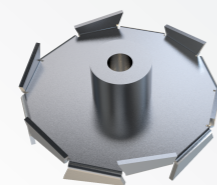

Saw Tooth



Line Flux

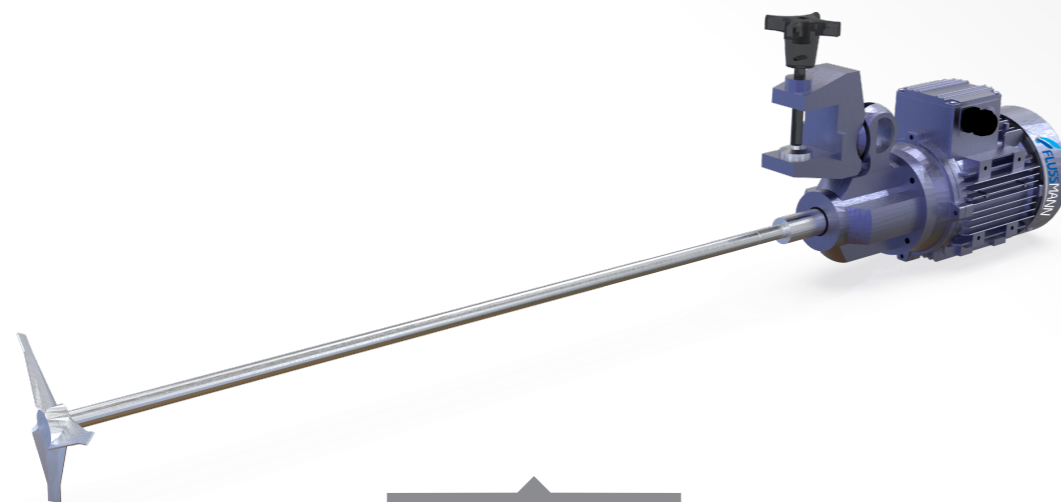

FAP PORTABLE AGITATOR

## FAV VERTICAL AGITATOR

### APPLICATION

- » FAV series agitators presents vertical direct motor-driven agitators.
- » High-speed agitation is required in the food processing, cosmetics, pharmaceutical or chemical industries.

### WORKING PRINCIPLE

- » The agitators are normally installed inside the tank either centrally with current deflectors,
- » The rotation of the propeller makes the fluid flow to the bottom and then up to the surface of the product along the walls of the tank.
- » The effect is promoted if the bottom of the tank is curved.

### DESIGN AND FEATURES

- » Vertical agitator.
- » Sealing: V-ring and retainer.
- » Bearing support.
- » IEC B14 motor, 1500 rpm, IP 55, F-class insulation.
- » Max. power 0.75 kW.

### MATERIALS

- » Parts in contact with the product : AISI 316L
- » V-ring and retainer : NBR
- » Bearing support : Aluminum

### OPTIONS

- » Motor cover
- » Atex motor
- » Motors: 1000 rpm or 1500 rpm
- » Geared motors or variable speed drives
- » Saw tooth impeller

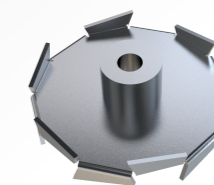

Saw Tooth

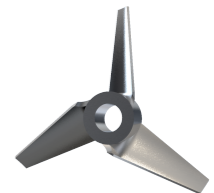

Line Flux

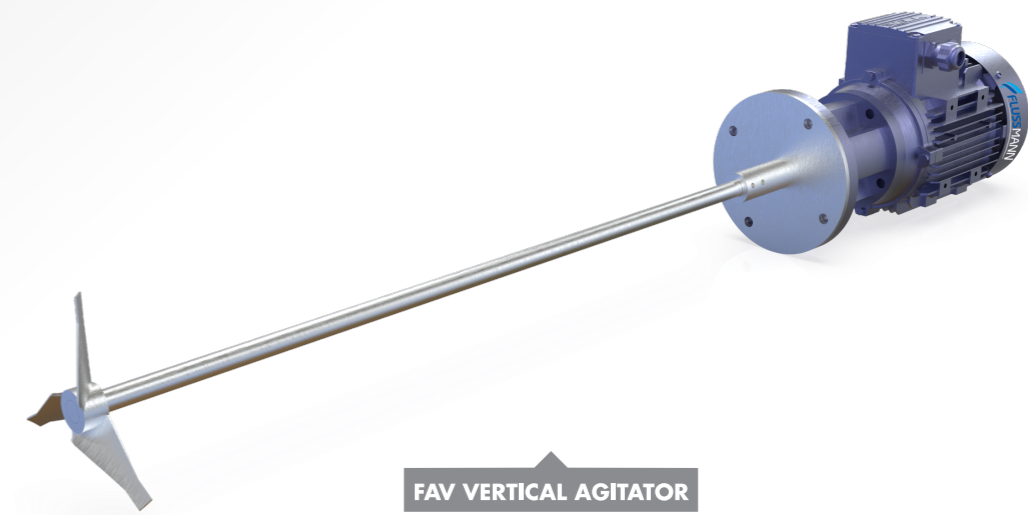

FAV VERTICAL AGITATOR