



GREENPUMPS

MAG - DRIVE SEAL- LESS PUMPS

**ALLOY ROTARY VANES PUMPS
SERIES GPA**



Zero leakages for environmental solution.

GREENPUMPS TECHNOLOGY INNOVATION AND RELIABILITY

GREENPUMPS is specialised in the design and application for water treatment, pharmaceutical, chemical, petrochemical and refinery applications. We continue every day to lead the way providing the most reliable sealless pumps available with the latest technology.

All GREENPUMPS sealless equipments are engineered to comply with the new environmental rules "1990 EPA Clean Air Act". Our mission is working for the future giving "zero emission" to preserve our environment.

GREENPUMPS GPA BENEFITS

GREENPUMPS GPA Sealless Sliding Vanes pumps are designed and fabricated for constant low flow and high head self regulating applications. All GREENPUMPS, due to the construction features are thought to have zero leakages even in extreme working conditions. The absence of mechanical seal or packing gland eliminates dangerous emissions in order to protect the environment and workers.

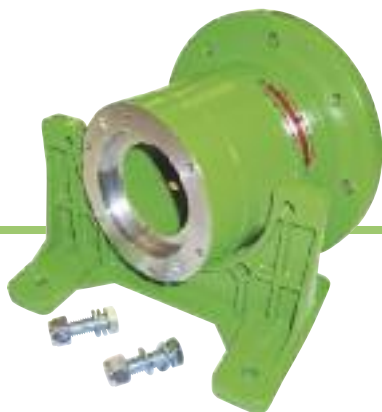

GREENPUMPS TECNOLOGIA E AFFIDABILITÀ

La GREENPUMPS è specializzata nella progettazione e nelle applicazioni dei processi per il trattamento acque, farmaceutici, chimici, petrolchimici e di raffinazione.

Ogni giorno ci impegniamo a progettare e produrre pompe a trascinamento magnetico che siano costruite con le tecnologie più avanzate.

Tutte le pompe GREENPUMPS a trascinamento magnetico sono in conformità con la normativa "1990 EPA Clean Air Act". La nostra missione è lavorare per il futuro dell'ambiente, senza emissioni nocive in atmosfera per poterlo preservare.

BENEFICI DELLE POMPE GREENPUMPS GPA

Le pompe a trascinamento magnetico GREENPUMPS della serie GPA, volumetriche a palette, sono progettate e costruite per un funzionamento a bassa portata e flusso costante, alta prevalenza, con pressione differenziale che si regola automaticamente.

Tutte le pompe GREENPUMPS, grazie alla loro robusta configurazione costruttiva, sono pensate per non avere pericolose perdite di liquido anche in condizioni di funzionamento estreme. L'assenza di tenuta meccanica o baderna assicura la totale eliminazione di emissioni pericolose, in modo da proteggere l'ambiente ed i lavoratori.

GREENPUMPS GPA SPECIFICATIONS

GREENPUMPS GPA Sliding Vane pump can maintain design head and flow for an extended running period because of self compensating carbon vanes.

GPA are suitable for thin non lubricating mediums, they eliminate pressure drop without rapid wear of carbon parts.

- Dry self-priming up to 2,5m (8 feet) of water
- Temperature range -70°C (-100°F) up to 250°C (480°F)
- Specific gravities up to 2 kg/dm^3
- Viscosities up to 2000 cPs (6 poles motor)
- System pressure rating 25 bar (350 PSI) special design up to 450 bar (6500 PSI)

GREENPUMPS GPA FEATURES

- Fully encapsulated external magnet
- Bronze Rub ring standard on coupling housing
- Dry Self-priming without damages
- No metal to metal contact, no internal slip
- Possibility to run with frequency converter
- Heavy duty machined pressure parts
- Easily replaceable carbon cartridge
- Low maintenance costs
- High MTBF (mean time between failure)
- High torque Cobalt Samarium magnets
- Easy removable pedestal for all frames
- Pumps are in accordance to ATEX regulation category

 II 2 G C T2-T6

SPECIFICHE DELLE POMPE GREENPUMPS GPA

Le pompe GREENPUMPS GPA possono mantenere a lungo la pressione e la portata richieste perché le palette interne in grafite compensano automaticamente l'eventuale usura dovuta allo strisciamento.

Le pompe GPA sono ideali per pompare liquidi scarsamente lubrificanti e per mantenere la pressione costante durante il normale funzionamento.

- Autoadescanti a secco fino a 2,5m di colonna d'acqua
- Campo di temperatura -70°C fino a 250°C
- Peso specifico fino a 2 kg/dm^3
- Viscosità fino a 2000 cPs (motore a 6 poli)
- Pressione di sistema standard 25 bar, applicazioni speciali fino a 450 bar

CARATTERISTICHE DELLE POMPE GREENPUMPS GPA

- Magnete esterno totalmente incapsulato
- Anello in bronzo (bronzina) standard installato nella lanterna di accoppiamento pompa motore
- Autoadescanti a secco senza danni per la pompa
- Nessun contatto metallo su metallo
- Possibilità di marcia con inverter
- Parti in pressione lavorate da barra piena
- Cartuccia interna in grafite facilmente sostituibile
- Bassi costi di manutenzione
- Alto valore di MTBF (tempo medio fra rotture)
- Magneti in Cobalto Samario ad alto momento torcente (coppia)
- Piedi del supporto facilmente rimovibili per tutta la serie
- Le pompe sono in accordo alla direttiva ATEX categoria

 II 2 G C T2-T6

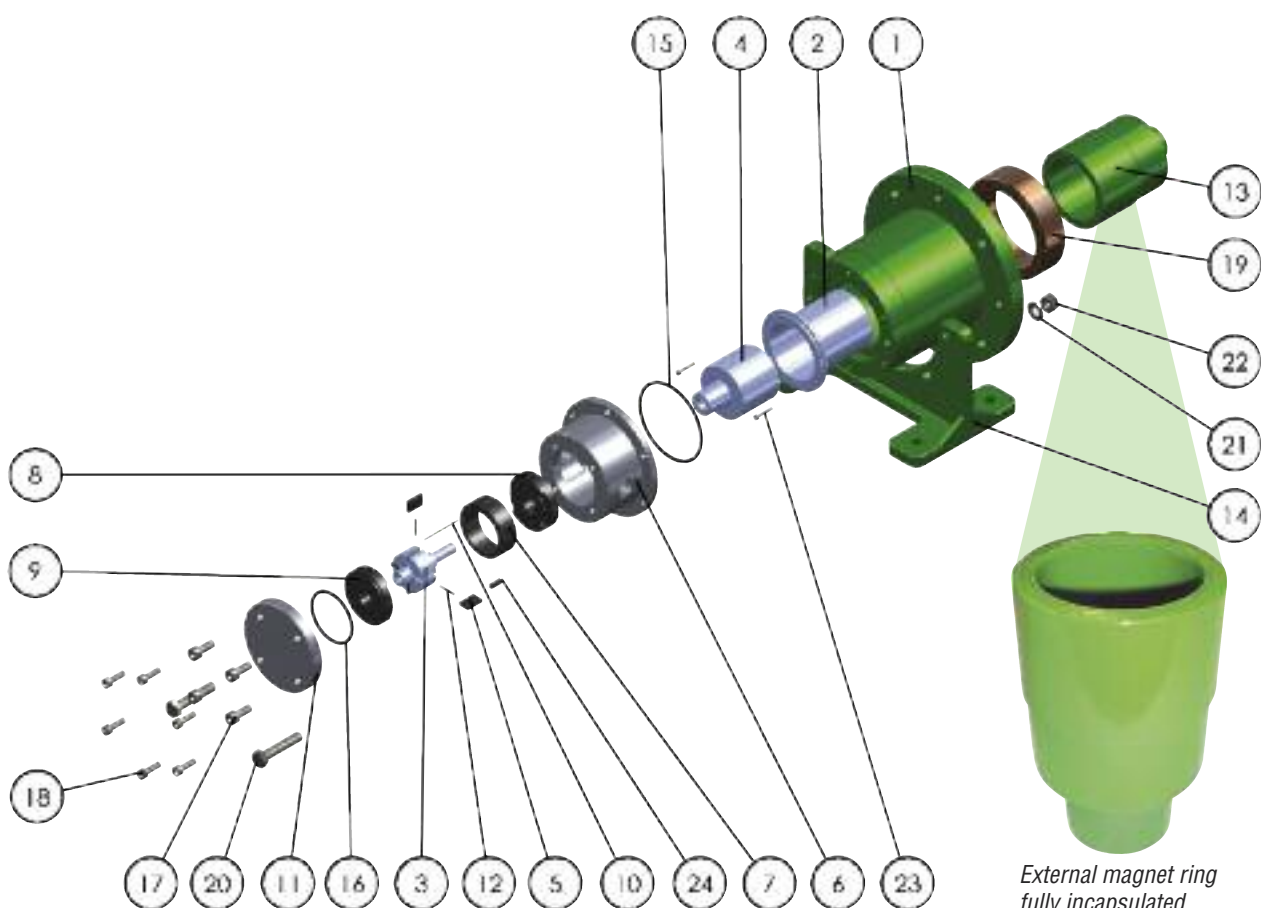

External magnet ring fully encapsulated.
Magnete esterno completamente incapsulato.

Ref. / Rif.	Description / Descrizione	Ref. / Rif.	Description / Descrizione
1	Coupling housing / Supporto pompa	13	External magnet ring / Magnete esterno
2	Containment shell / Bicchiere di contenimento	14	Coupling housing feet / Piedi supporto pompa
3	Rotor shaft / Albero rotore	15	Rear O-Ring / O-Ring posteriore
4	Internal magnet ring / Magnete interno	16	Front O-Ring / O-Ring anteriore
5	Vane / Paletta	17	End cover screw / Vite coperchio
6	Pump casing / Corpo pompa	18	Pump casing screw / Vite corpo pompa
7	Stator ring carbon / Statore grafite	19	Rub ring / Anello di strisciamento (Bronzina)
8	Rear flange carbon / Flangia posteriore grafite	20	Coupling housing feet screw / Vite piede supporto pompa
9	Front flange carbon / Flangia anteriore grafite	21	Washer / Rondella
10	Alignment pin / Spina di allineamento	22	Nut / Dado
11	End cover / Coperchio corpo pompa	23	Rub ring screw / Vite anello di strisciamento
12	Vane pin / Spina della paletta	24	Rotor shaft key / Chiavetta albero rotore

Typical services

- Pumping dangerous and radioactive liquids
- Transfer of solvents, acids, alkali, refrigerants
- Pilot plants
- Refineries sampling
- Mechanical seal flushing
- Chemical processing
- Hydrocarbon processing / Refining
- Municipal (scrubber system)
- Biofuels
- Pulp and Paper
- Pharmaceutical processes

Applicazioni tipiche

- Pompaggio di liquidi pericolosi e radioattivi
- Trasferimento solventi, acidi, alcali, refrigeranti
- Impianti pilota
- Campionatura analisi
- Flussaggio tenute meccaniche
- Processi chimici
- Processi petrolchimici
- Trattamento acque e lavaggi torri di processo
- Biocarburanti
- Cartiere
- Processi farmaceutici

GPA

950 RPM (50 Hz)

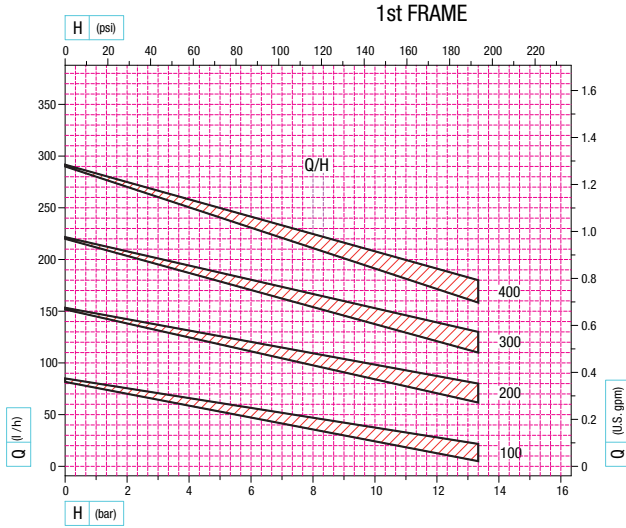

GPA

1450 RPM (50 Hz)

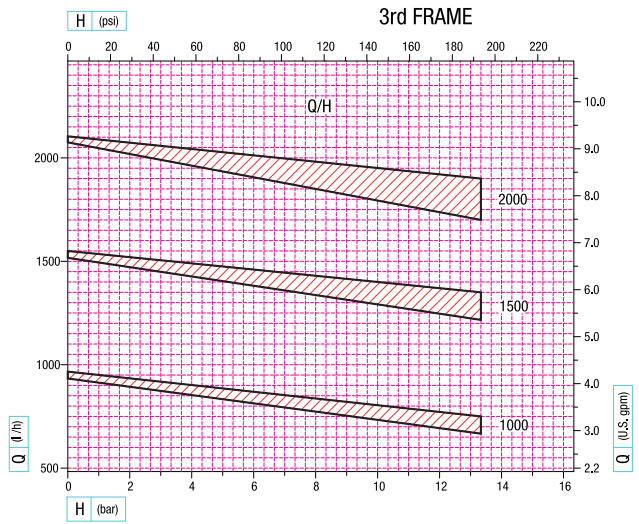
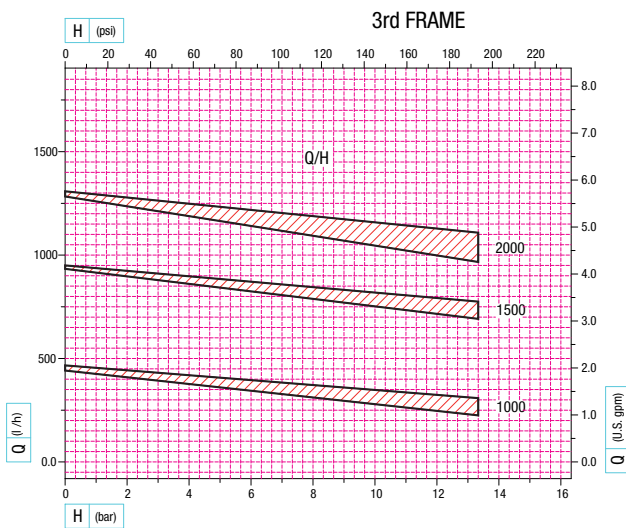
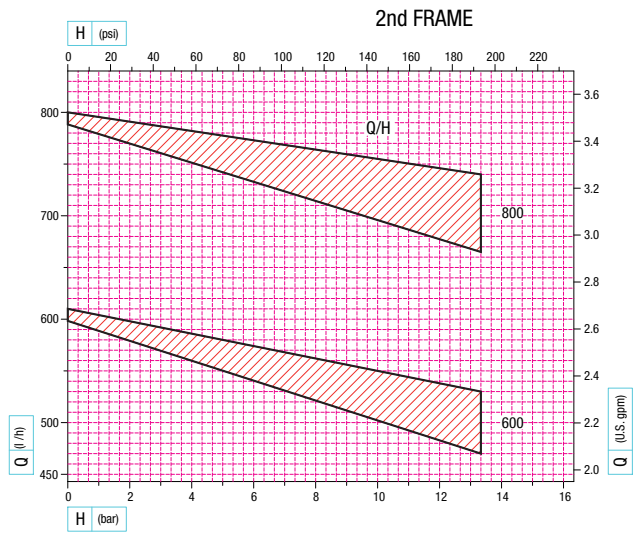
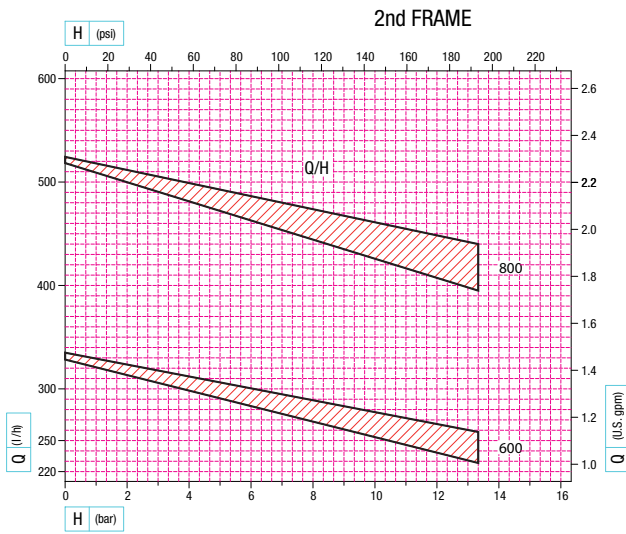
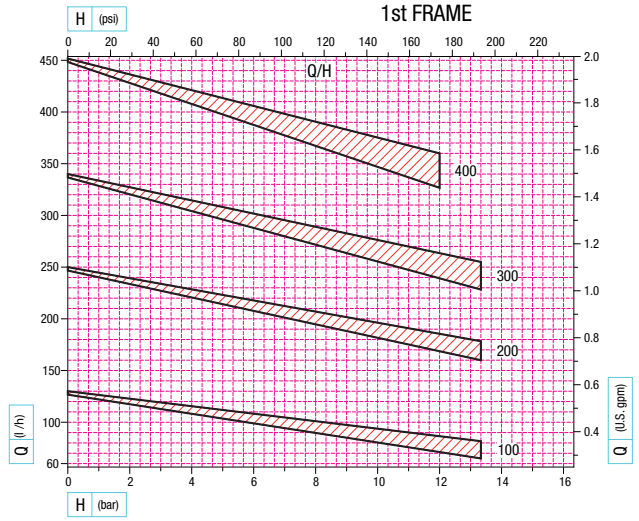

GPA

1150 RPM (60 Hz)

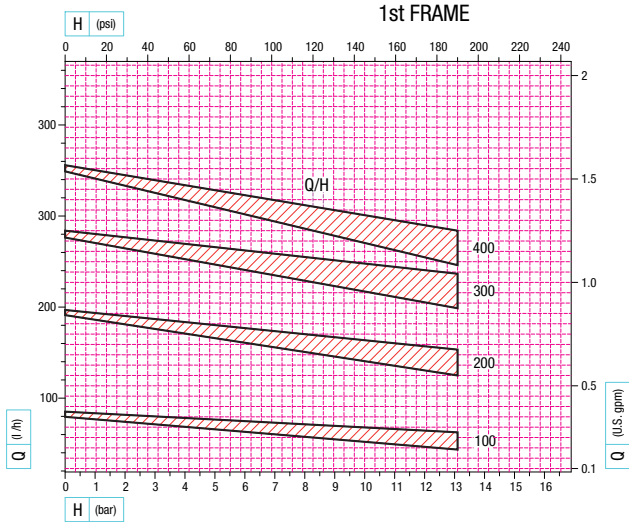

GPA

1750 RPM (60 Hz)

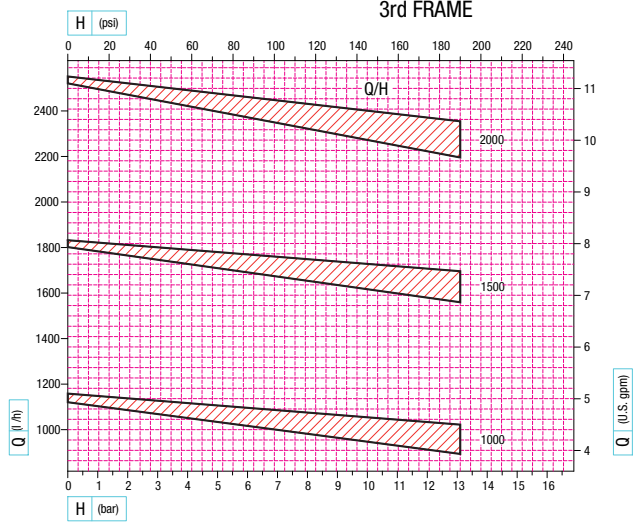
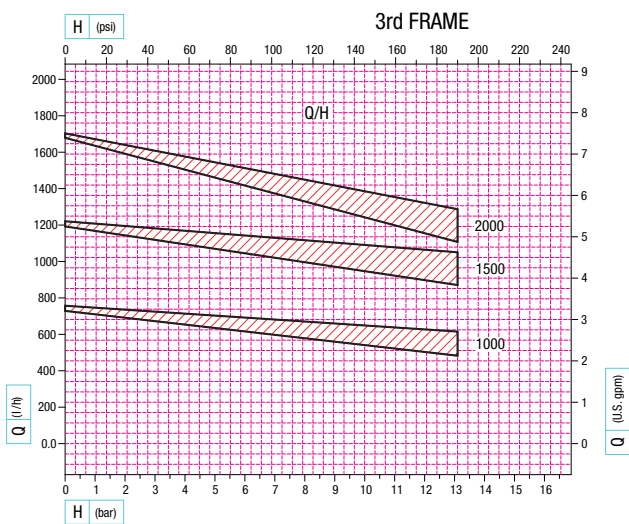
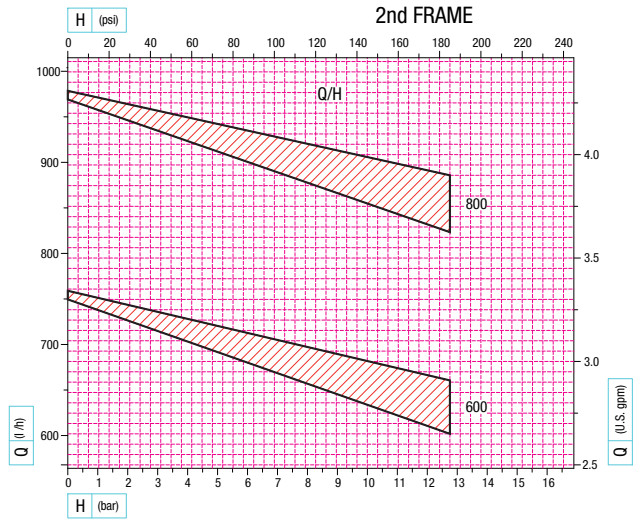
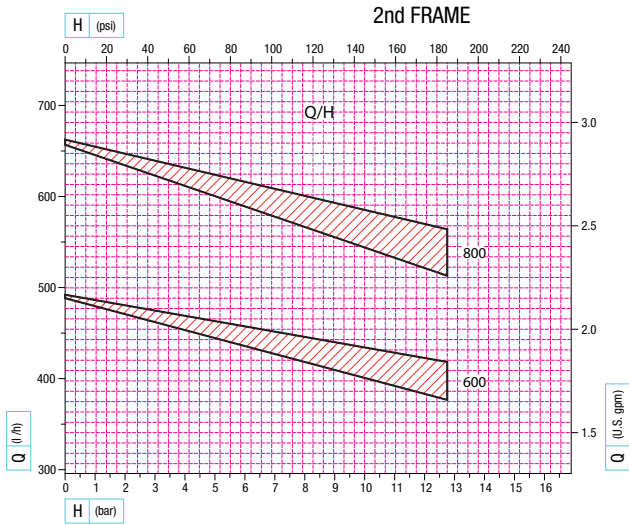
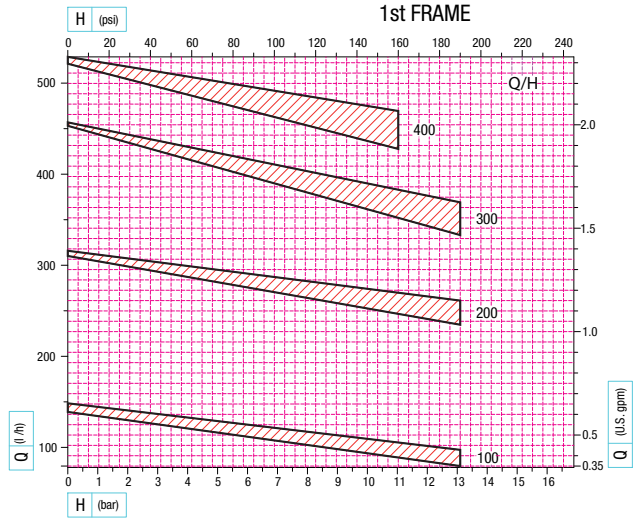

OVERALL DIMENSIONS DIMENSIONI INDICATIVE

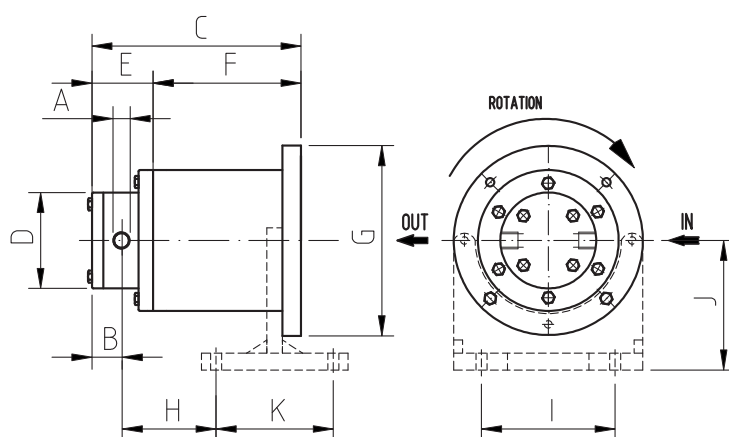

1° FRAME

PUMPS GPA 100 200 300 400												mm
A	B	C	D	E	F	G	H	I	J	K		inches
3/8" FPT	26	153	70	48	105	140	160	62	135	86	80	WEIGHT
3/8" NPT	1"	6"	2 3/4"	1 7/8"	4 1/8"	5 1/2"	6 1/4"	2 1/2"	5 3/8"	3 1/2"	3"	3,5Kg
												lbs7

2° FRAME

PUMPS GPA 600 800												mm
A	B	C	D	E	F	G	H	I	J	K		inches
1/2" FPT	36	204	95	66	138	200	94	175	115	98	WEIGHT	
1/2" NPT	1 3/8"	8"	3 3/4"	2 5/8"	5 1/2"	7 7/8"	3 3/4"	6 3/4"	4 1/2"	3 3/4"	6Kg	
											lbs12	

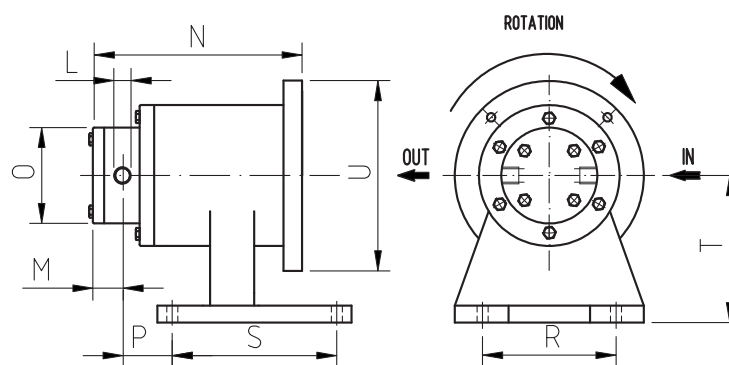

3° FRAME

PUMPS GPA 1000 1500 2000											mm
L	M	N	O	P	R	S	T	U			inches
3/4" FPT	47	256	123	90	155	192	134	200	WEIGHT		
3/4" NPT	1 7/8"	10"	4 7/8"	3 1/2"	6 1/8"	7 1/2"	5 1/4"	7 7/8"	14Kg		
										lbs28	

Construction materials

- Stainless Steel SS316L
- Incoloy 825™
- Alloy 20™
- Hastelloy C-276™
- Duplex
- Other materials on request

Materiali

- Acciaio inossidabile SS316L
- Incoloy 825™
- Alloy 20™
- Hastelloy C-276™
- Duplex
- Altri materiali a richiesta

GREENPUMPS GPA options & special executions

- Flanged ports ISO / ANSI
- Tri-clamp ports
- High temperature design
- Low temperature design
- High pressure design
- Special polished finishing
- Jacketed coupling housing
- Jacketed end cover
- Thermowell

Opzioni ed esecuzioni speciali pompe GREENPUMPS GPA

- Connessioni flangiate ISO / ANSI
- Connessioni con Tri-clamp
- Configurazione per alta temperatura
- Configurazione per bassa temperatura
- Configurazione per alta pressione
- Finitura lucidata a specchio
- Supporto pompa motore incamiciato
- Coperchio pompa incamiciato
- Pozzetto PT 100

*Special execution for sanitary applications.
All wetted parts polished with roughness less than 0,6 $\mu\text{m Ra}$*

Esecuzione speciale per uso sanitario.
Tutte le parti a contatto con il liquido, vengono lucidate con rugosità superficiale inferiore a 0,6 $\mu\text{m Ra}$



*Complete polished pump with tri-clamps connections
Pompa completa lucidata con connessioni sanitarie tri-clamps*



*Completely polished internal magnet ring
Magnete interno completamente lucidato*



*Completely polished containment shell
Bicchiere di contenimento completamente lucidato*

GP SERIES

Greenpumps Dry Running Protector



	PD - 05	PD - 30	PD - 60
<i>Current range / Campo funzionamento</i>	0.5 - 6 A	3.0 - 20 A	5.0 - 60 A
<i>Trip time setting / Regolaz. tempo di interv.</i>	0.2 - 30 sec.		
<i>Power supply / Alimentazione</i>	3 phase 220V AC		
<i>Output relay / Uscita</i>	3A 250V AC		

GREENPUMPS dry run protector

- Compact design
- Two internal current transformers
- Wide range current adjustment
- Definite trip time characteristic
- Manual (immediate) / Electric remote reset
- Easy maintenance

Strumento contro la marcia a secco GREENPUMPS

- Forma compatta
- Due trasformatori di corrente interni
- Larga gamma di regolazioni
- Tempo di intervento tarabile
- Manuale (immediata) / Azzeramento elettrico a distanza
- Manutenzione facile

www.greenpumps.it

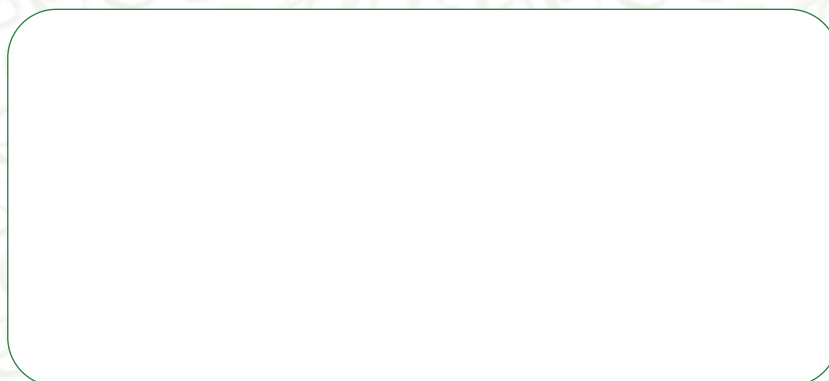

Via dell'Industria, 29 - 35020 Brugine - PADOVA - ITALY

Tel. +39 049 973 02 32 - +39 049 973 01 71

Fax +39 049 973 02 40