

C-22/C-23/C-24 Contents

	Page
Specifications	2
Installation	4
Disc Arrangement	5
C-22 Parts	6
C-23 Parts	8
C-24 Parts	10
Repair & Troubleshooting	11

C-22/C-23/C-24 Specifications

Specifications

Capacity	Maximum		Minimum	
	gpm	l/min	gpm	l/min
C-22	10	37.8	3	11.3
C-23	20	75.7	3	11.3
C-24	40	151.4	5	18.9

Pressure Range	Model Configuration			
	AA	AB	AC	AE
psi				
C-22	75-500	500-1000	1000-1500	1500-2500
C-23	75-500	500-1000	1000-1500	1500-2500
C-24	75-500	500-1000	1000-1500	—
bar				
C-22	5.3-34.5	34.5-69	69-103	103-172
C-23	5.3-34.5	34.5-69	69-103	103-172
C-24	5.3-34.5	34.5-69	69-103	—

Max Temperature: 200°F

Inlet and Outlet Ports:

C-22	3/4" NPT
C-23	1" NPT
C-24	1-1/4" NPT

Dimensions: (H x W x D)

C-22- AA, AB, AC	6.0 x 3.4 x 2.2 in. (152.4 x 86.4 x 55.9 mm)
C-22- AE	6.4 x 3.4 x 2.2 in. (163.6 x 86.4 x 55.9 mm)
C-23-AA, AB, AC	7.0 x 4.8 x 2.8 in. (178 x 122 x 71.1 mm)
C-23-AE	7.4 x 4.8 x 2.8 in. (188 x 122 x 71.1 mm)
C-24-AA, AB, AC	9.0 x 5.4 x 3.3 in. (229 x 137.2 x 83.8 mm)

Weight

C-22	3 lbs (1.3 kg)
C-23	6 lbs (2.7 kg)
C-24	10 lbs (4.5 kg)

C-22/C-23/C-24 Installation

Location

The Bypass Pressure Regulating Valve prevents system pressure from exceeding a preset maximum. As the system approaches this maximum pressure, excess fluid is bypassed (to a supply tank, or to the pump inlet). This prevents overpressurization and system failures.

Install the regulating valve between the pump outlet (as close to the pump as possible) and any shut-off device in the discharge plumbing. It may be located **in** the discharge line, or **off**-line:

- If in-line, use either of the horizontal ports as the inlet and the other as the outlet;
- If off-line, use either of the horizontal ports as the inlet and plug the other one.

The **bottom** port is always the bypass port.

Mounting Position

The preferred mounting position is vertical with the adjusting bolt at the top.

Connections

For best operation, the bypass line should return to the supply tank. If you must plumb the bypass line back to the pump inlet instead, have it enter the inlet line as far from the pump as possible. Contact the pump manufacturer, as a pressure regulator may be required in the pump inlet.

The bypass line should be as large as the ports of the regulating valve. Do **not** install shutoff valves or other restrictions.

Install a high-quality industrial pressure gauge in the discharge system to monitor system pressure. Failure to do so may result in overpressurization and premature failure of pumping system components.

For smoothest operation and minimal pressure spiking when the discharge system is closed (closed gun, plugged nozzles, valve closed), about 10% of the rated flow of the regulating valve should be bypassed at all times.

Example: With the C22A valve (rated at 10 gpm), 1 gpm should be bypassing at all times during operation. If the desired spray gun delivery is 6 gpm, then the pump should deliver 7 gpm (6 gpm to the gun and 1 gpm to be bypassed). The nozzle orifices should be properly sized for 6 gpm delivery at the desired pressure; the pump RPM for 7 gpm; and the pump HP for 7 gpm at the bypass pressure (bypass pressure is higher than nozzle pressure).

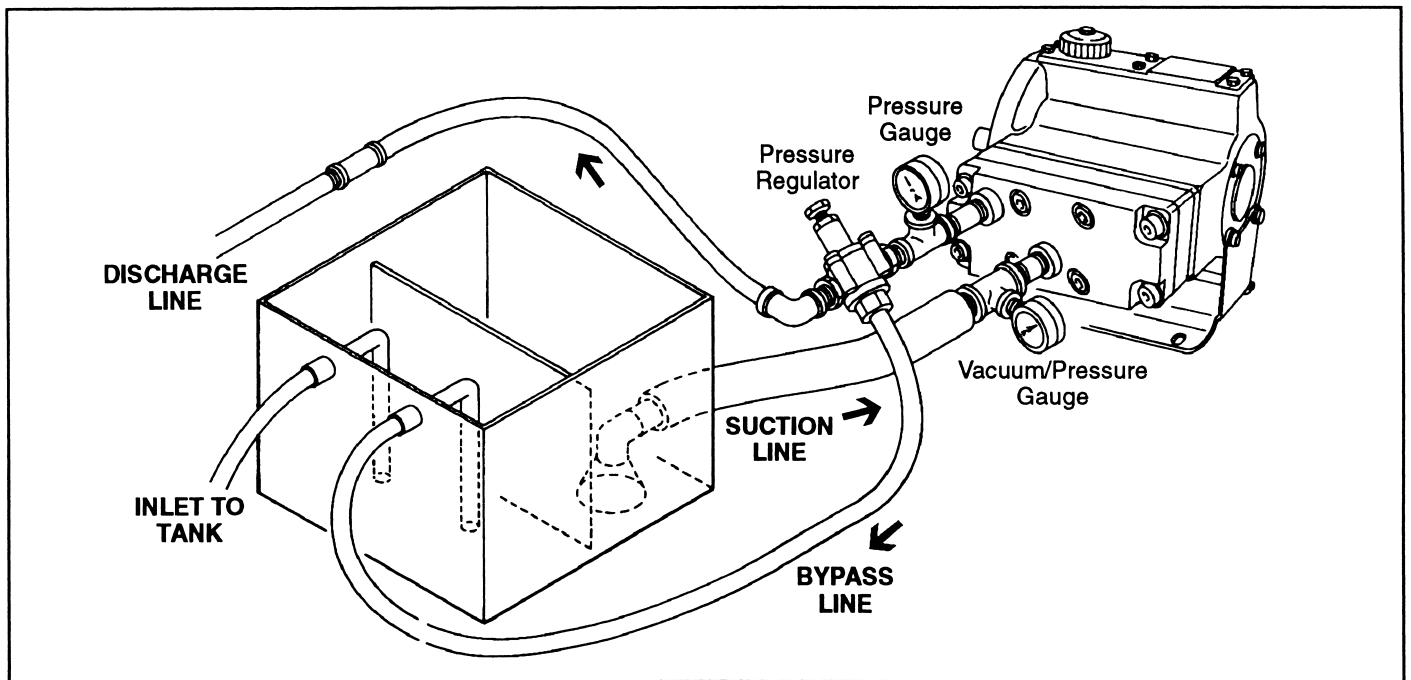

C-22/C-23/C-24 Installation

Pressure Adjustment

Systems *with* Shutoff Guns or Valves

1. Turn off the system.
2. Turn the adjusting nut counterclockwise until there is no longer any pressure on the springs in the regulating valve.
3. Close the discharge line.
4. Be sure the piping and all valves and nozzles are open.
With an accurate pressure gauge installed in the system, start the system and let it run for a few minutes to remove any air.
5. When all air has been removed, begin turning the adjusting nut clockwise until the desired bypass pressure is reached.
Do not exceed the maximum rated pressure of the pump or the regulating valve!
6. Open and close the discharge line 3 or 4 times. Re-check the bypass pressure each time, and readjust if necessary. Turn the adjusting nut clockwise to increase or counterclockwise to reduce the pressure.
7. Check that the fluid bypass is continuous and adequate. With guns or valves open, you should be bypassing about 10% of the rated flow of the regulating valve (see the Example above). If the system discharge pressure is less than desired when 10% of the flow is bypassing, check the pump speed and delivery and the size of the nozzle or system orifice.
8. When both the bypass pressure and the flow have been set, turn the locknut clockwise to lock in the adjustment.

Systems *without* Shutoff Guns or Valves

Note: When making this adjustment, you must be able to observe the amount of fluid being bypassed.

1. Turn off the system.
2. Turn the adjusting nut counterclockwise until there is no longer any pressure on the springs in the regulating valve.
3. With an accurate pressure gauge installed in the system start the system and let it run for a few minutes to remove any air. The full flow of the pump should be bypassing.
4. Be sure all nozzles are open.
5. When all air has been removed, begin turning the adjusting nut clockwise until the desired bypass pressure is reached, or until no fluid is being bypassed — whichever occurs first.
Do not exceed the maximum rated pressure of the pump or the regulating valve!
6. If the system discharge pressure is less than desired, check the pump speed and delivery and the size of the nozzle or system orifice.
7. When both the bypass pressure and the flow have been set, turn the locknut clockwise to lock in the adjustment.

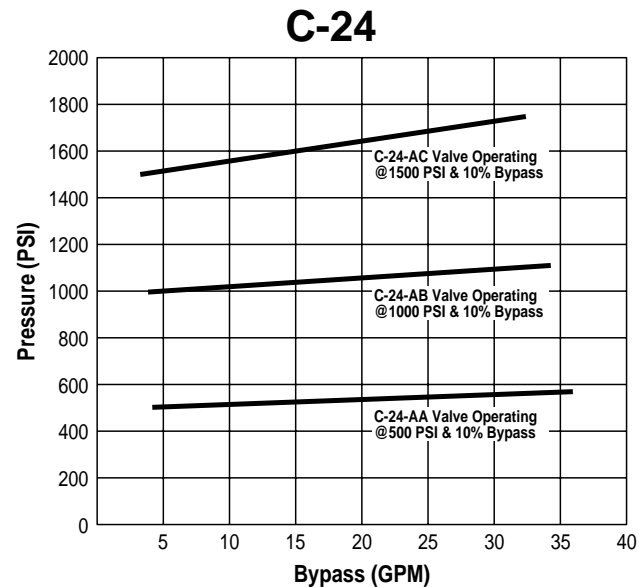
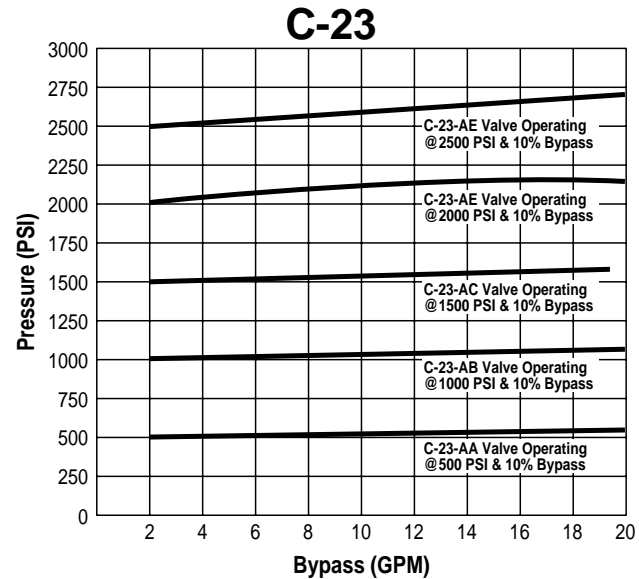
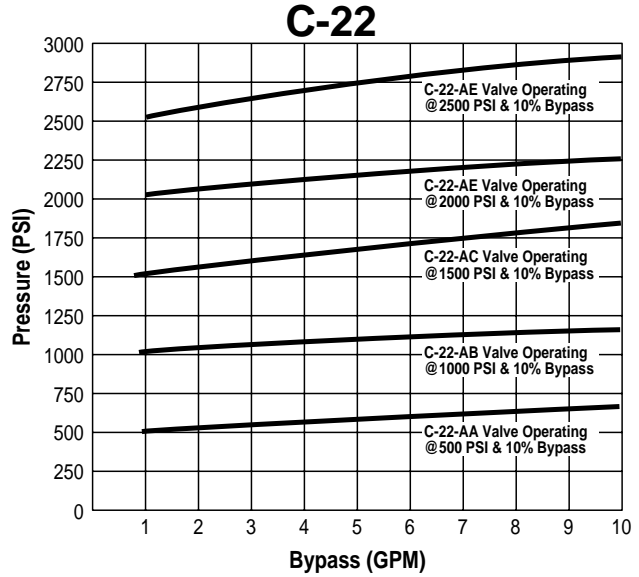

Spring Disc Arrangement

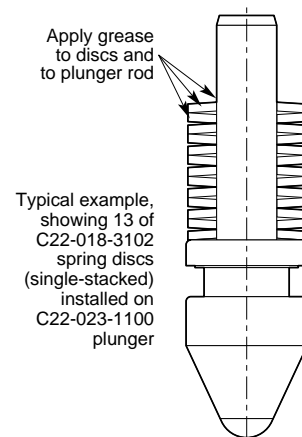
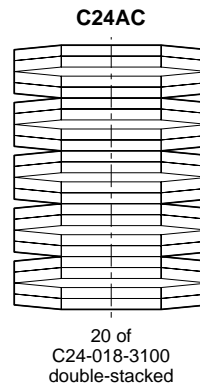
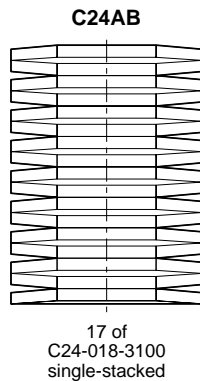
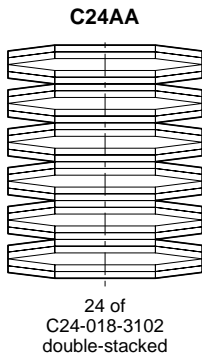
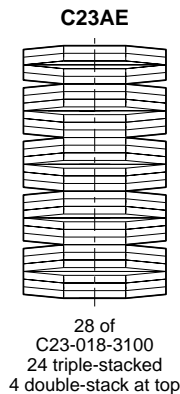
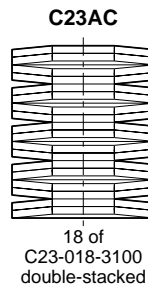
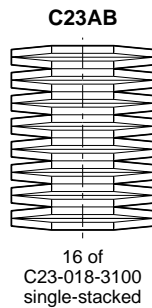
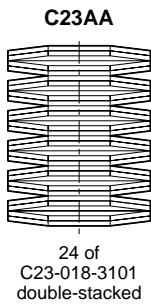
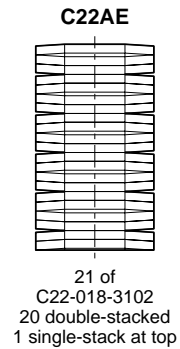
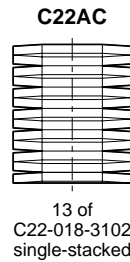
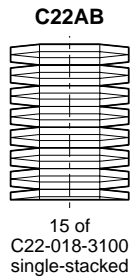
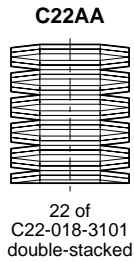

Spring Disc Size and Arrangement

Valve Model	GPM	PSI	Disc Size OD x ID x Thickness	Quantity Used
C-22-AA	3-10	75-500	20 x 10.2 x 0.8 mm	22 (double stack)
C-22-AB	3-10	500-1000	20 x 10.2 x 1.2 mm	15 (single stack)
C-22-AC	3-10	1000-1500	20 x 10.2 x 1.5 mm	13 (single stack)
C-22-AE	3-10	1500-2500	20 x 10.2 x 1.5 mm	1 (single stack); 20 (double stack)
C-23-AA	3-20	75-500	28 x 12.2 x 1.0 mm	24 (double stack)
C-23-AB	3-20	500-1000	28 x 12.2 x 1.5 mm	16 (single stack)
C-23-AC	3-20	1000-1500	28 x 12.2 x 1.5 mm	18 (double stack)
C-23-AE	3-20	1500-2500	28 x 12.2 x 1.5 mm	4 (double stack); 24 (triple stack)
C-24-AA	5-40	75-500	35.5 x 18.3 x 1.2 mm	24 (double stack)
C-24-AB	5-40	500-1000	35.5 x 18.3 x 2.0 mm	17 (single stack)
C-24-AC	5-40	1000-1500	35.5 x 18.3 x 2.0 mm	20 (double stack)