

PARTS MANUAL

Hydra-Cell[®]

INDUSTRIAL PUMPS

IMPORTANT

Record your pump model number and serial number here for easy reference:

Model No. _____

Serial No. _____

Date of Purchase _____

When ordering parts or making inquiries about this pump, please mention the model and serial numbers.

MODEL: D-04

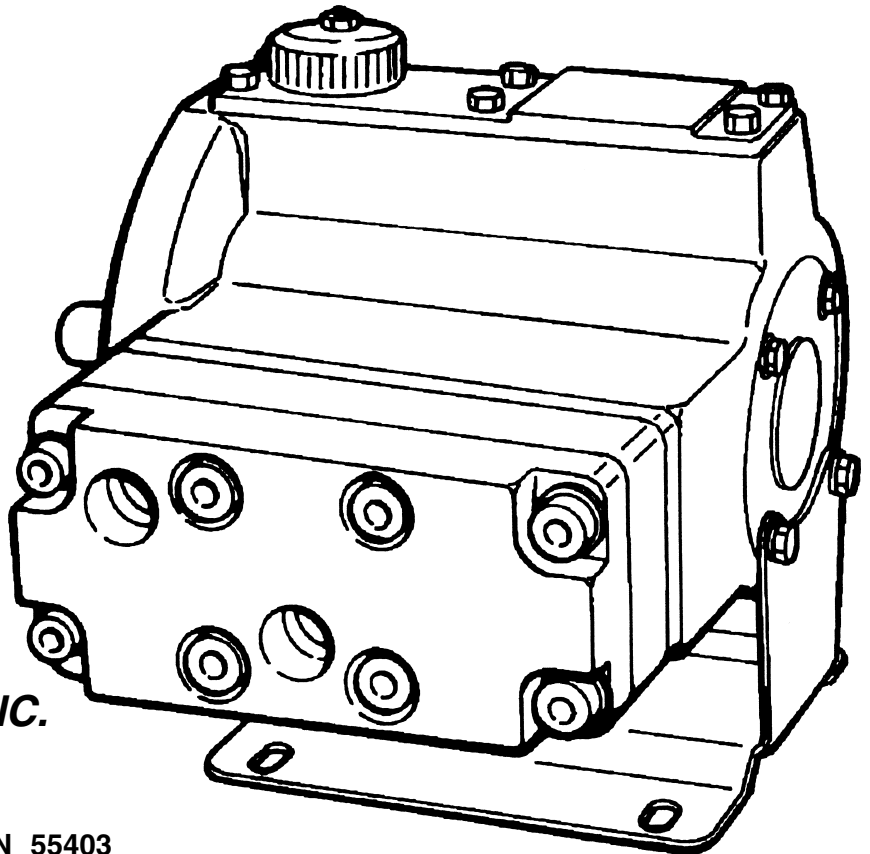

WANNER ENGINEERING, INC.

1204 Chestnut Avenue, Minneapolis, MN 55403
TEL: (612) 332-5681 FAX: (612) 332-6937
TOLL-FREE FAX [US only]: (800) 332-6812

www.hydra-cell.com

email: sales@wannereng.com

Document Fax Back System (510) 745-0440

D-04 Fluid End

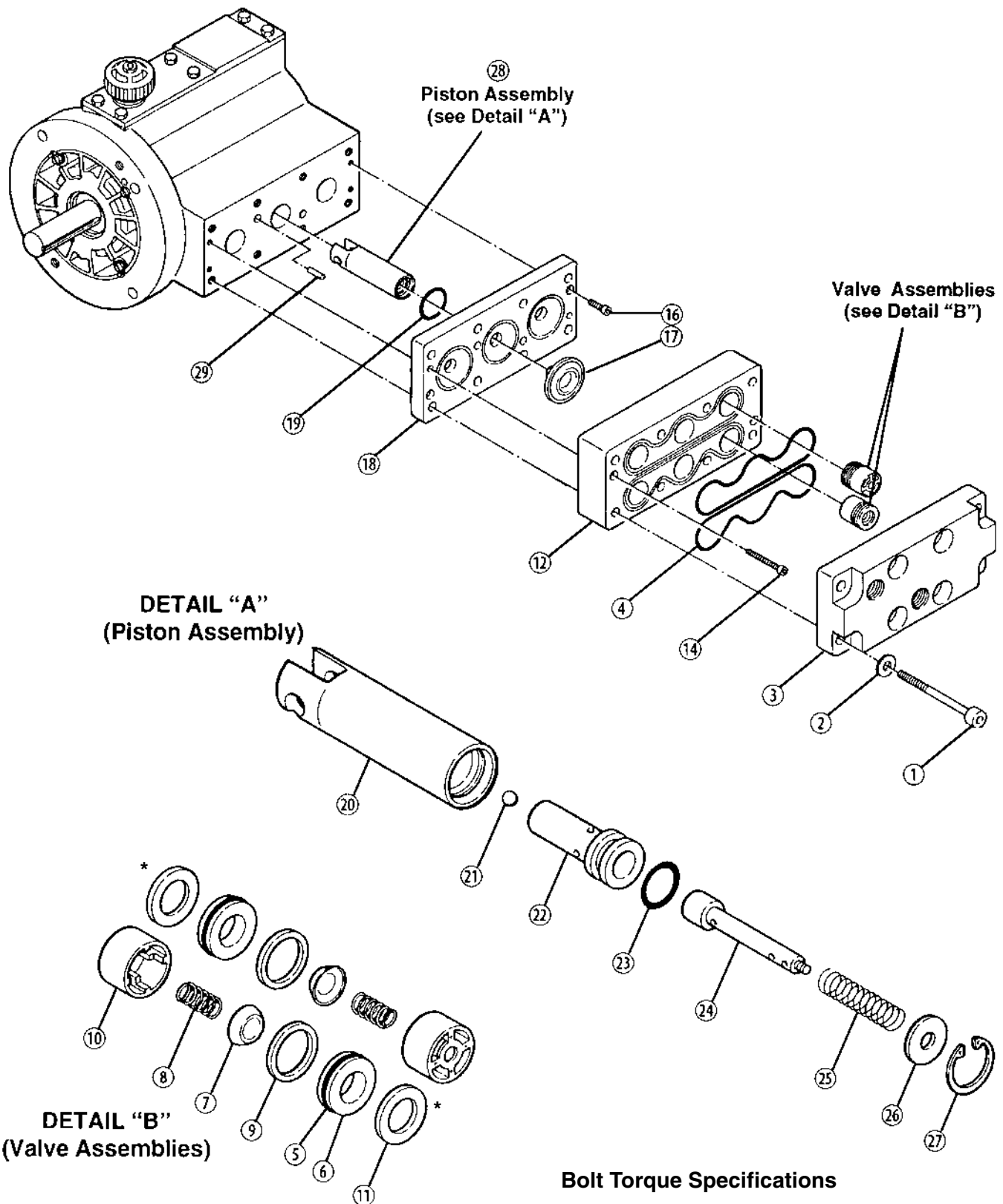

* Note: dampening washer (11) not used in newer models. The thickness of valve seat (6) is increased on newer models to eliminate the need for the dampening washers.

Bolt Torque Specifications

Ref. No.	D-04
1	50 ft-lbs
17	10 in-lbs

D-04 Fluid End

Ref #	Part Number	Description	Quantity/ Pump
1	G10-024-2010	Cap Screw, socket-head, M10 x 1.5 x 90 mm	8
2	D11-048-2011	Washer, flat, hardened	8
3	D03-004-1040	Manifold, brass	1
	D03-004-1034	Manifold, 304 SST	1
4	D03-073-2140	O-ring, manifold, Buna	2
	D03-073-2141	O-ring, manifold, Viton	2
5	D25-046-2110	O-ring, valve seat, Buna	6
	D25-046-2111	O-ring, valve seat, Viton	6
6	D15-020-2010	Valve Seat, Nitronic 50	6
	D15-020-2011	Valve Seat, 17-4 SST	6
	D15-020-2016	Valve Seat, carbide	6
	D15-020-2017	Valve Seat, Hastelloy C	6
7	D03-021-1011	Valve, Nitronic 50	6
	D03-021-1015	Valve, 17-4, machined	6
	D03-021-1016	Valve, carbide	6
	D03-021-1017	Valve, Hastelloy C	6
8	D03-022-3113	Valve Spring, Hastelloy C	6
	D03-022-3114	Valve Spring, Elgiloy	6
	D03-022-3118	Valve Spring, 316 SST	6
9	D03-092-2110	Tetra Seal, Buna	6
	D03-092-2111	Tetra Seal, Viton	6
10	D03-023-1010	Retainer, valve spring, 17-7 SST	6
	D03-023-1017	Retainer, valve spring, Hastelloy C ...	6
	D03-023-2310	Retainer, valve spring, Celcon	6
	D03-023-2316	Retainer, valve spring, Nylon	6
	D03-023-2317	Retainer, valve spring, polypropylene	6
	D03-023-2318	Retainer, valve spring, Kynar	6

Ref #	Part Number	Description	Quantity/ Pump
11	D03-125-1011	Washer, dampening, SST	6
12	D03-003-1030	Valve Plate, brass	1
	D03-003-1034	Valve Plate, 304 SST	1
14	G10-088-2010	Cap Screw, socket-head, M6 x 1.0 x 30 mm	2
16	G03-088-2010	Cap Screw, socket-head, M6 x 1.0 x 20 mm	2
17	D03-018-1240	Diaphragm, Buna-N-XS	3
	D03-018-1245	Diaphragm, Viton-XT	3
18	D03-002-1012	Diaphragm Plate, steel	1
19	D03-075-2110	O-ring, diaphragm plate, Buna	3
20	D03-014-1004	Piston	3
21	D10-015-3010	Ball	3
22	D03-043-1000	Valve Cylinder	3
23	D03-034-2110	O-ring, valve cylinder, Buna	3
24	D03-044-1000	Valve Plunger	3
25	D03-045-3110	Spring, sleeve valve	3
26	D03-049-1000	Washer	3
27	D03-048-2210	Snap Ring	3
28	D03-014-1210	Piston Assembly	3
29	D03-026-2210	Pin	2

D-04 Hydraulic End

**MODEL D-04
STANDARD PUMP BASEPLATE SHOWN**
(refer to illustration below when motor adapter is used)

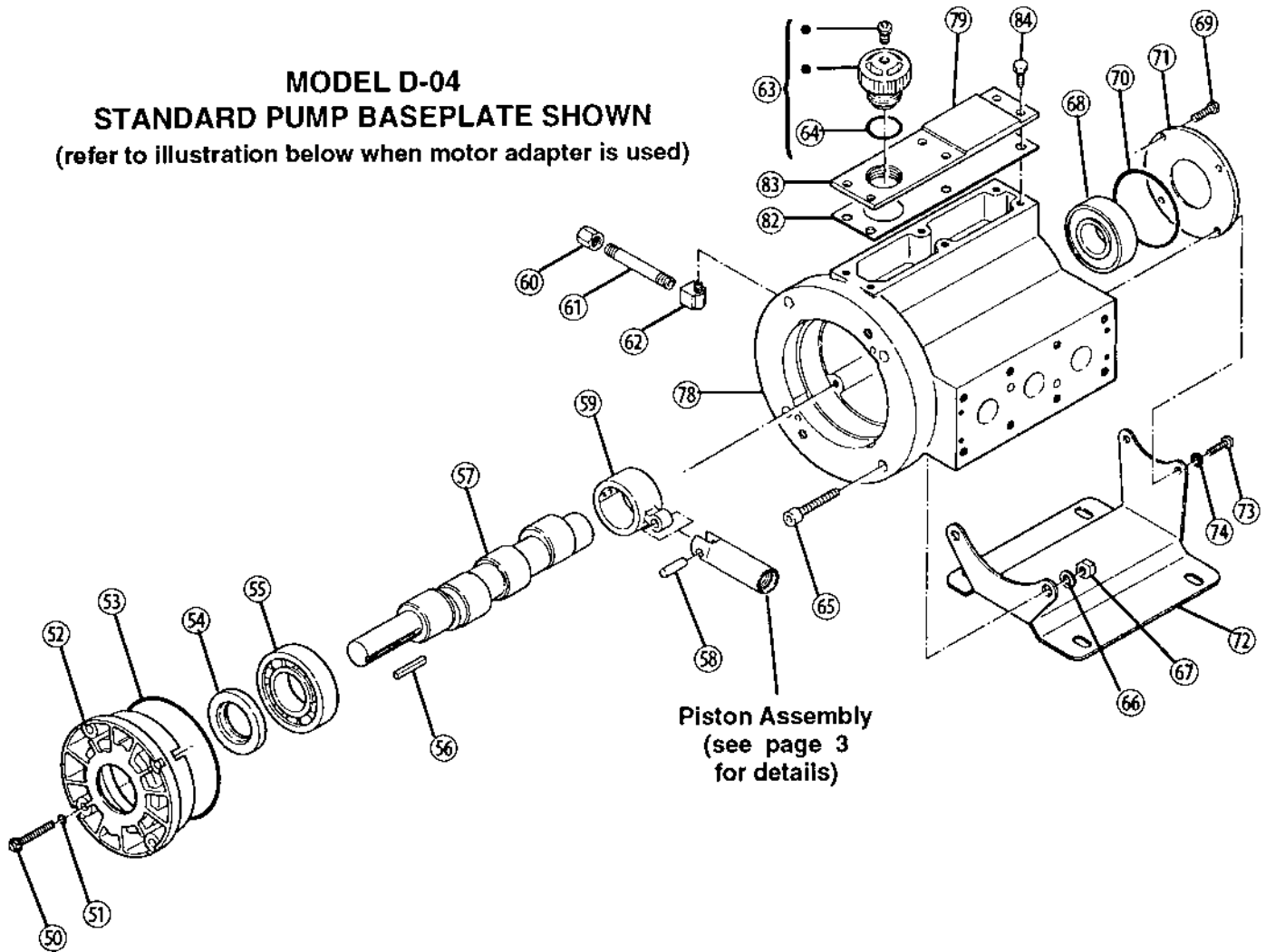

Piston Assembly
(see page 3
for details)

**PUMP HOUSING,
WITH MOTOR ADAPTER***

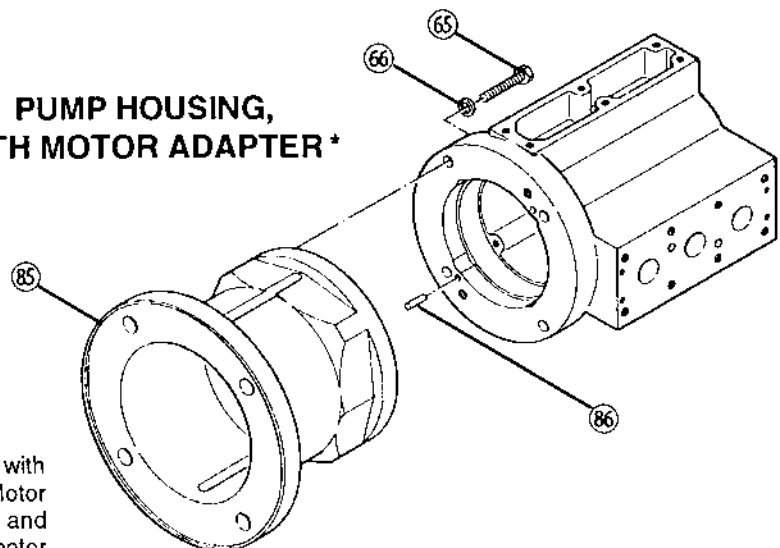

* NOTE: Motor Adapter is not supplied with pump, and must be purchased separately. Motor Adapter Kit includes all screws, washers, and pins required to connect it to the pump and motor (but does not include shaft coupling).

D-04 Hydraulic End

Ref #	Part Number	Description	Quantity/ Pump
50	G03-086-2010	Bolt, hex flange, M6 x 1.0 x 40 mm ...	4
51	D25-047-2110	O-ring, back cover screws, Buna	4
52	D03-131-1000	Back Cover	1
53	D03-037-2110	O-ring, back cover, Buna	1
54	D03-031-2110	Seal, Buna	1
55	D03-011-2910	Back Bearing	1
56	D10-085-2210	Key, shaft	1
57	D03-009-1048	Crank Shaft, shaft-driven, 7/8" O.D., 1.8 GPM @ 1750 RPM	1
	D03-009-1042	Crank Shaft, shaft-driven, 7/8" O.D., 2.2 GPM @ 1750 RPM	1
	D03-009-1040	Crank Shaft, shaft-driven, 7/8" O.D., 3.0 GPM @ 1750 RPM	1
58	D03-133-1000	Pin	3
59	D03-132-1004	Connecting Rod, aluminum-bronze ...	3
60	D10-078-2210	Cap, brass, 1/8"	1
61	D10-077-2210	Pipe, brass, 1/8"	1
62	D10-076-2210	Elbow, brass, 1/8"	1
63	D03-039-1210	Cap, oil fill (includes breather & O-ring)	1
64	D10-080-2110	O-ring, oil fill, Buna	1
65	G03-068-2010	Cap Screw, socket-head, M10 x 1.5 x 40 mm ¹	2

Ref #	Part Number	Description	Quantity/ Pump
66	G25-048-2010	Washer, M10 ¹	2
67	G10-028-2010	Nut, hex, M10 ²	2
68	D03-010-2910	Front Bearing	1
69	D03-087-2010	Cap Screw, hex-head, 1/2" ¹	2
70	D40-074-2110	O-ring, front cover, Buna	1
71	D03-130-1000	Front Cover	1
72	D03-025-1010	Base Plate	1
73	D03-089-2010	Cap Screw, hex-head, 3/4" ¹	2
74	D03-050-2010	Washer, lock ²	2
78	G03-001-1218	Pump Housing Assembly ⁵	—
	G03-001-1228	Pump Housing ⁵	1
79	D10-040-2410	Name Plate	1
82	G25-106-2318	Gasket, cover	1
83	H25-105-1018	Cover, housing	1
84	G25-090-2010	Cap Screw, hex-head, M8 x 1.25 x 16 mm	6
85	A04-001-1202	Adapter, motor, NEMA 56C-145TC ⁵ ..	1
	A04-002-1202	Adapter, motor, NEMA 182TC-215TC ⁵	1
86	D03-026-2211	Pin ³	2

¹ Qty: 2 on pumps with baseplate (72); 4 on pumps with motor adapter (85).

² Qty: 2 on pumps with baseplate (72); not included on pumps with motor adapter (85).

³ Qty: 2 on pumps with motor adapter (85); 4 on pumps with baseplate (72).

⁴ Pump Housing Assembly includes housing (78), drain plug (60, 61, 62) and from bearing (68).

⁵ Motor adapter is not supplied with pump, and must be purchased separately. Motor Adapter Kit includes all screws, washers, and pins required to connect it to the pump and motor (but does not include shaft coupling.)

D-04 Series Replacement Parts Kits

TO ORDER REPLACEMENT PARTS KIT: A Replacement Parts Kit contains 11 digits corresponding to customer-specified design options.

1	2	3	4	5	6	7	8	9	10	11
---	---	---	---	---	---	---	---	---	----	----

Digit	Order Code	Description
1-3		Pump Configuration
	D04	For all D-04 Pumps
4		Kit Designator
	K	Complete Fluid End Kit
	D	Diaphragm Kit
	V	Valve Kit (diaphragm not included)
5-6		Pump Head Version
	51	Pump Head Version
7		Diaphragm & O-ring Material
	G	Viton®-XT
	T	Buna-N-XS
8		Valve Seat Material
	D	Tungsten Carbide
	H	17-4 PH Stainless Steel
	N	Nitronic 50
	T	Hastelloy® C
	X	Not included in Diaphragm Kit
9		Valve Material
	D	Tungsten Carbide
	F	17-4 PH Stainless Steel – Machined
	N	Nitronic 50
	T	Hastelloy® C
	X	Not included in Diaphragm Kit
10		Valve Springs
	E	Elgiloy®
	S	316 Stainless Steel
	T	Hastelloy® C
	X	Not included in Diaphragm Kit
11		Valve Spring Retainers
	C	Celcon
	H	17-7 PH Stainless Steel
	M	Kynar®
	P	Polypropylene
	T	Hastelloy® C
	Y	Nylon
	X	Not included in Diaphragm Kit

Kit Contents

Part Number*	Description	Qty	Kit Designator		
			K	D	V
D03-018-___	Diaphragm	3	•	•	
D25-073-___	O-ring, manifold	2	•	•	•
D25-046-___	O-ring, valve seat	6	•		•
D03-020-___	Valve seat	6	•		•
D03-021-___	Valve	6	•		•
D03-022-___	Valve spring	6	•		•
D03-092-___	Tetra seal	6	•		•
D03-023-___	Retainer, valve spring	6	•		•
D03-125-1011**	Washer, dampening	6	•		•
A01-113-3400	Threadlocker	1	•	•	

* Last four digits of part numbers with —___ refer to specific material of construction.

** Note: dampening washer not used in newer models. The thickness of valve seat is increased on newer models to eliminate the need for the dampening washers.



WANNER ENGINEERING, INC.

1204 Chestnut Avenue, Minneapolis, MN 55403
 TEL: (612) 332-5681 FAX: (612) 332-6937
 TOLL-FREE FAX [US only]: (800) 332-6812

www.hydra-cell.com

email: sales@wannereng.com

Document Fax Back System (510) 745-0440