

G03 Series

Maximum Flow Rate: 11.7 l/min (3.1 gpm)
Maximum Pressure: 103 bar (1500 psi) for Metallic Pump Heads
24 bar (350 psi) for Non-metallic Pump Heads



WANNER
Hydra-Cell[®]
Seal-less Pump Technology



G03 Shaft-driven with Stainless Steel pump head



G13 Close-coupled with Polypropylene pump head

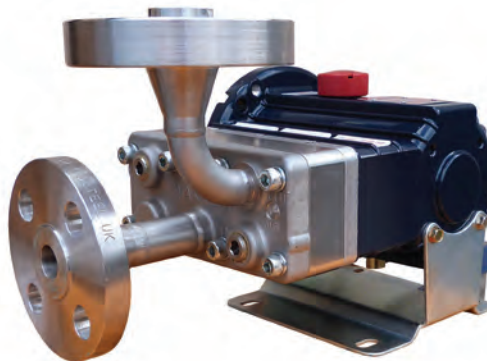

G03 with Stainless Steel pump head and ANSI RF flanges



G13 Close-coupled with Brass pump head

G03 Series Performance

Capacities

Flow

Model	Max. Input rpm	Max. Flow @ 69 bar (1000 psi)	
		gpm	l/min
G03-X	1750	3.1	11.7
G03-E	1750	2.2	8.3
G03-S	1750	1.7	6.4
G03-B	1750	1.0	3.6
G03-G	1750	0.6	2.3
@ 83 bar (1200 psi)			
G03-E	1750	2.1	8.1
G03-S	1750	1.6	6.3
G03-B	1750	0.9	3.5
G03-G	1750	0.6	2.2

Pressure

Maximum Inlet Pressure
17 bar (250 psi)

Maximum Discharge Pressure

Metallic Pump Heads:

G03-X to 103 bar (1500 psi)

G03-S, E, B, G to 83 bar (1200 psi)

Non-metallic Pump Heads:

17 bar (250 psi) Polypropylene

24 bar (350 psi) PVDF

Performance and specification ratings apply to G03 Kel-Cell and G03 Shaft-driven configurations unless specifically noted otherwise.

Metering & Dosing

API 675 Performance Characteristics of Steady State Accuracy $\pm 1\%$, Linearity $\pm 3\%$ and Repeatability $\pm 3\%$ can be achieved at speeds up to 1440 rpm and pressures up to 24 bar (non-metallic pump heads) or up to 69 bar (metallic pump heads) for X-cam pumps only.

Maximum Flow at Designated Pressure

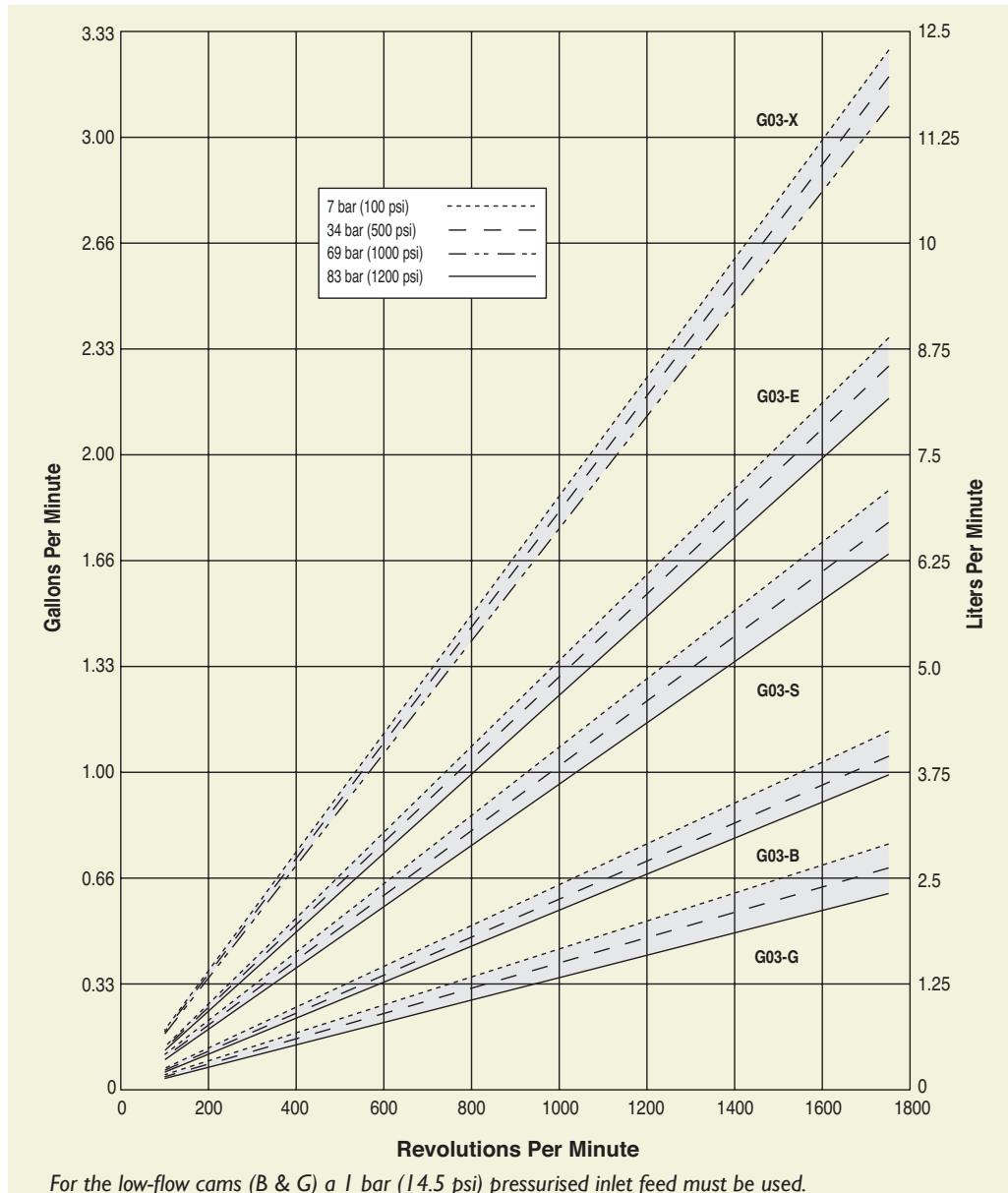

G03 Series Specifications

Flow Capacities @ 69 bar (1000 psi) 4-pole Motor @ 50 Hz

Model	rpm	gpm	l/min
G03-X	1450	2.45	9.3
G03-E	1450	1.80	6.8
G03-S	1450	1.48	5.6
G03-B	1450	0.92	3.5
G03-G	1450	0.40	1.5

Flow Capacities @ 69 bar (1000 psi) 6-pole Motor @ 50 Hz

Model	rpm	gpm	l/min
G03-X	960	1.64	6.2
G03-E	960	1.18	4.5
G03-S	960	0.98	3.7
G03-B	960	0.60	2.3
G03-G	960	0.26	1.0

Delivery @ 83 bar (1200 psi)

Model	gal/rev	liters/rev
G03-E	0.0012	0.0046
G03-S	0.0009	0.0036
G03-B	0.0005	0.0020
G03-G	0.0003	0.0013

Delivery @ 69 bar (1000 psi)

Model	gal/rev	liters/rev
G03-X	0.0018	0.0067
G03-E	0.0013	0.0047
G03-S	0.0010	0.0037
G03-B	0.0005	0.0021
G03-G	0.0004	0.0013

Maximum Discharge Pressure

Metallic Heads:	G03-X to 103 bar (1500 psi)
	G03-S, E, B to 83 bar (1200 psi)
	G13 X, E to 69 bar (1000 psi)
Non-metallic Heads:	17 bar (250 psi) Polypropylene
	24 bar (350 psi) PVDF

Maximum Inlet Pressure 17 bar (250 psi)

Maximum Operating Temperature

Metallic Heads:	121 °C (250 °F) - Consult factory for correct component selection for temperatures from 71 °C (160 °F) to 121 °C (250 °F).
	Non-metallic Heads:
	60 °C (140 °F)

Maximum Solids Size 200 microns

Inlet Port

1/2 inch BSPT
1/2 inch NPT
300lb ANSI RF Flange
PN40 DN20 DIN Flange
1 inch Tri-clamp

Discharge Port

3/8 inch BSPT
3/8 inch NPT
600lb ANSI RF Flange
PN100 DN15 DIN Flange
3/4 inch Tri-clamp

Shaft Diameter

G13: 24 mm (0.945 inch) hollow shaft
G03: 22.2 mm (7/8 inch)

Shaft Rotation

Reverse (bi-directional)

Bearings

Precision ball bearings

Oil Capacity

0.95 litres (1.0 US quart)

Weight

Metallic Heads:	12.7 kg (28 lbs.)
Non-metallic Heads:	8.6 kg (19 lbs.)

Calculating Required Power

$$\frac{6 \times \text{rpm}}{63,000} + \frac{\text{gpm} \times \text{psi}}{1,460} = \text{electric motor hp}$$

$$\frac{6 \times \text{rpm}}{84,428} + \frac{\text{l/min} \times \text{bar}}{511} = \text{electric motor kW}$$

Calculating Pulley Size

$$\frac{\text{motor pulley OD}}{\text{pump rpm}} = \frac{\text{pump pulley OD}}{\text{motor rpm}}$$

When using a variable frequency controller (VFD) calculate the hp or kW at minimum and maximum pump speed to ensure the correct hp or kW motor is selected. Note that motor manufacturers typically de-rate the service factor to 1.0 when operating with a VFD.

Net Positive Suction Head (NPSHr)

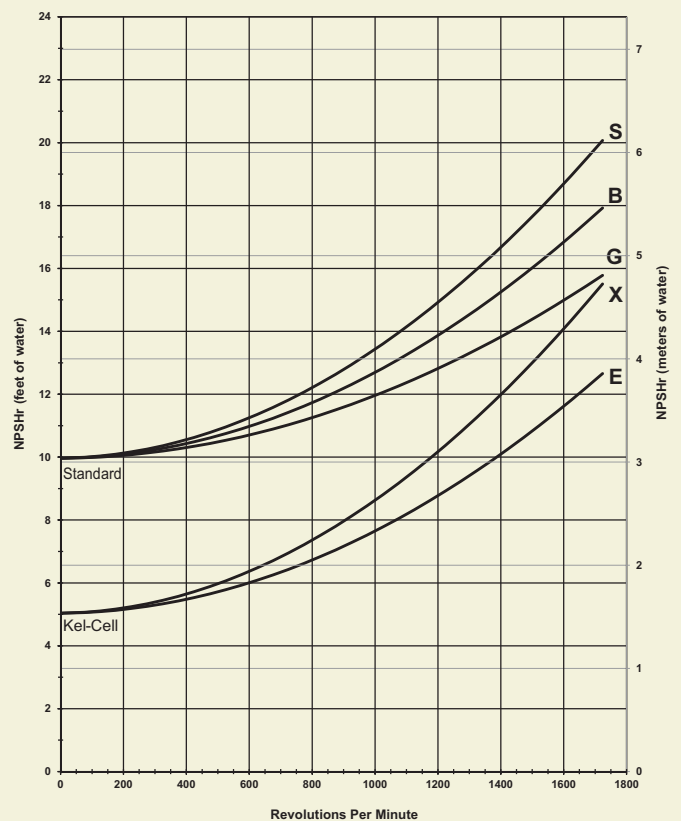

Note: Positive inlet pressure required with PTFE diaphragms.

Self-priming:

Each Hydra-Cell pump has different lift capability depending on model size, cam angle, speed, and fluid characteristics. To ensure that your specific lift characteristics are met, refer to the inlet calculations regarding friction, and acceleration head losses in your Hydra-Cell Installation & Service Manual. Compare those calculations to the NPSHr curves above.

G03 Series General Assemblies

Baseplate Assembly with Motor Adaptor for IEC 90 Motor Frame

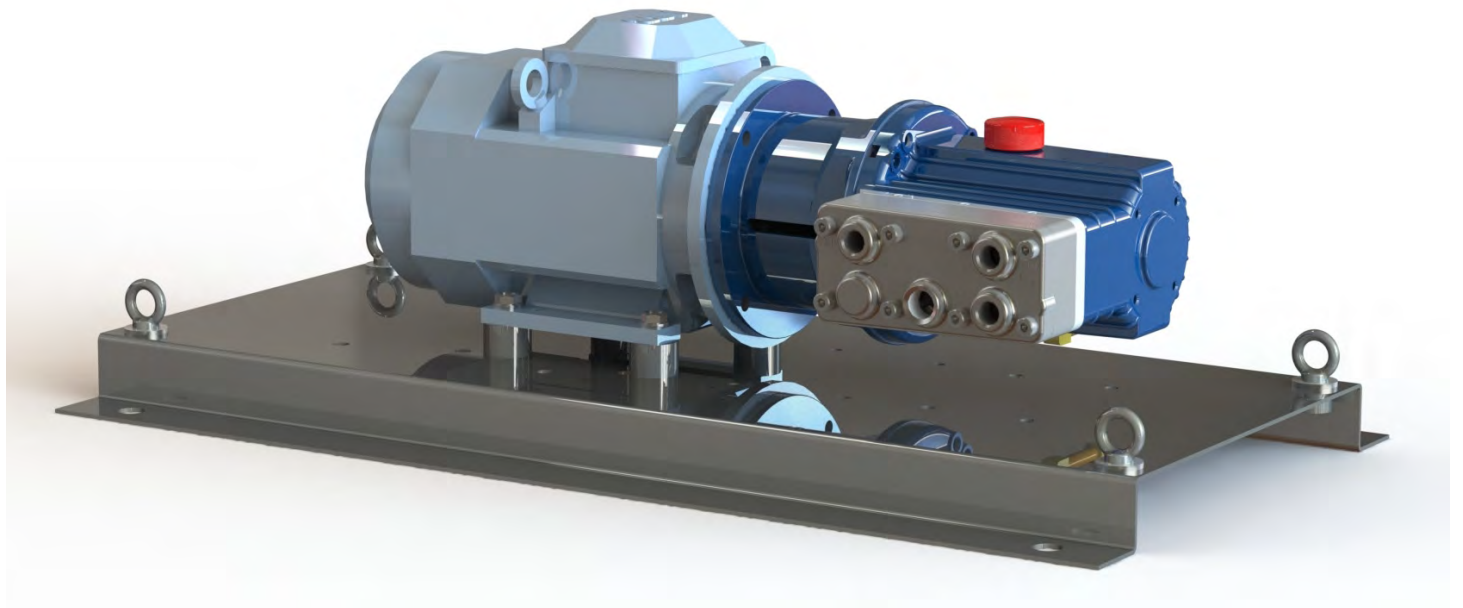

Dimensions in mm

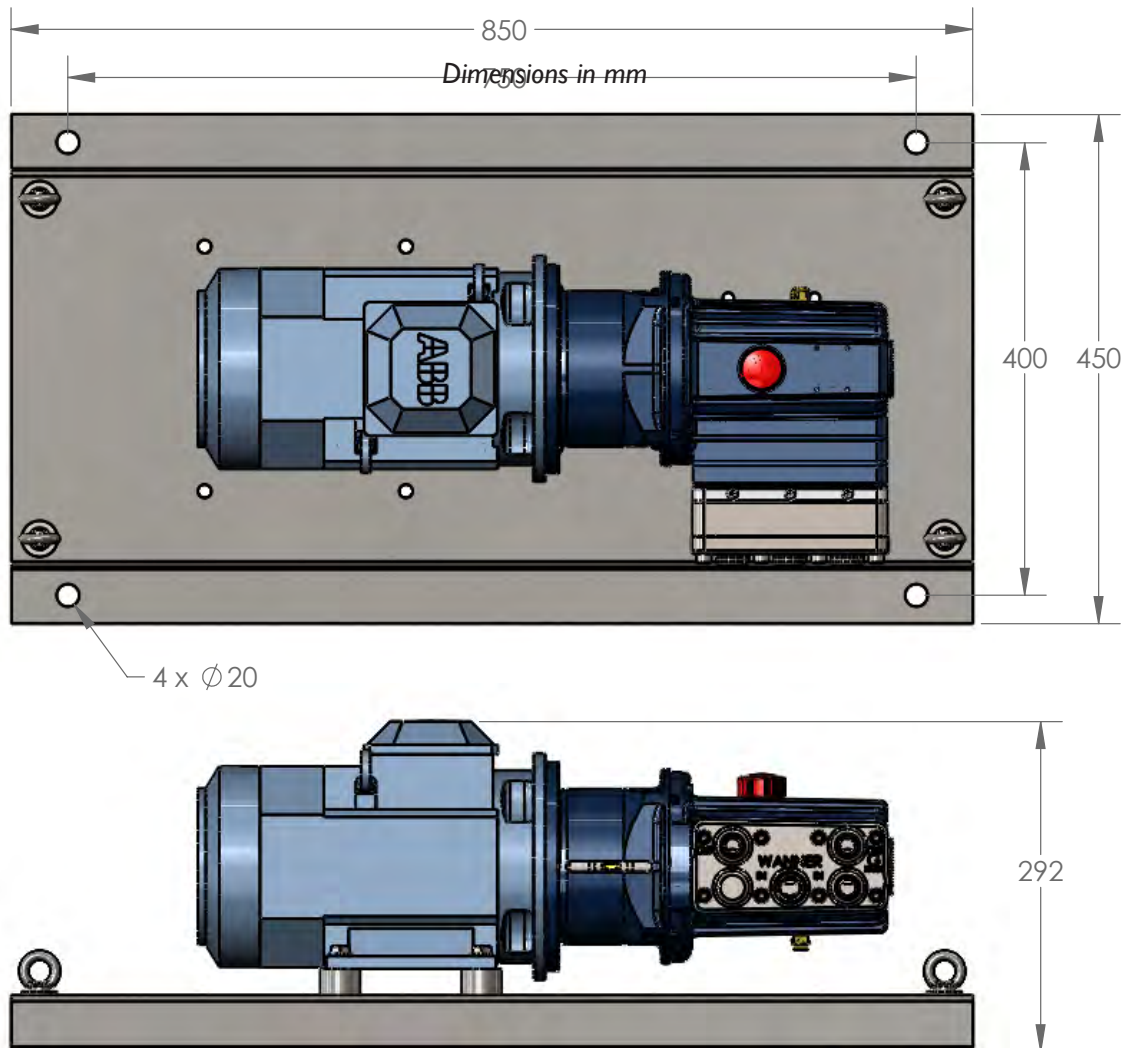

G03 Series General Assemblies

Baseplate Assembly with Motor Adaptor for IEC 100 Motor Frame

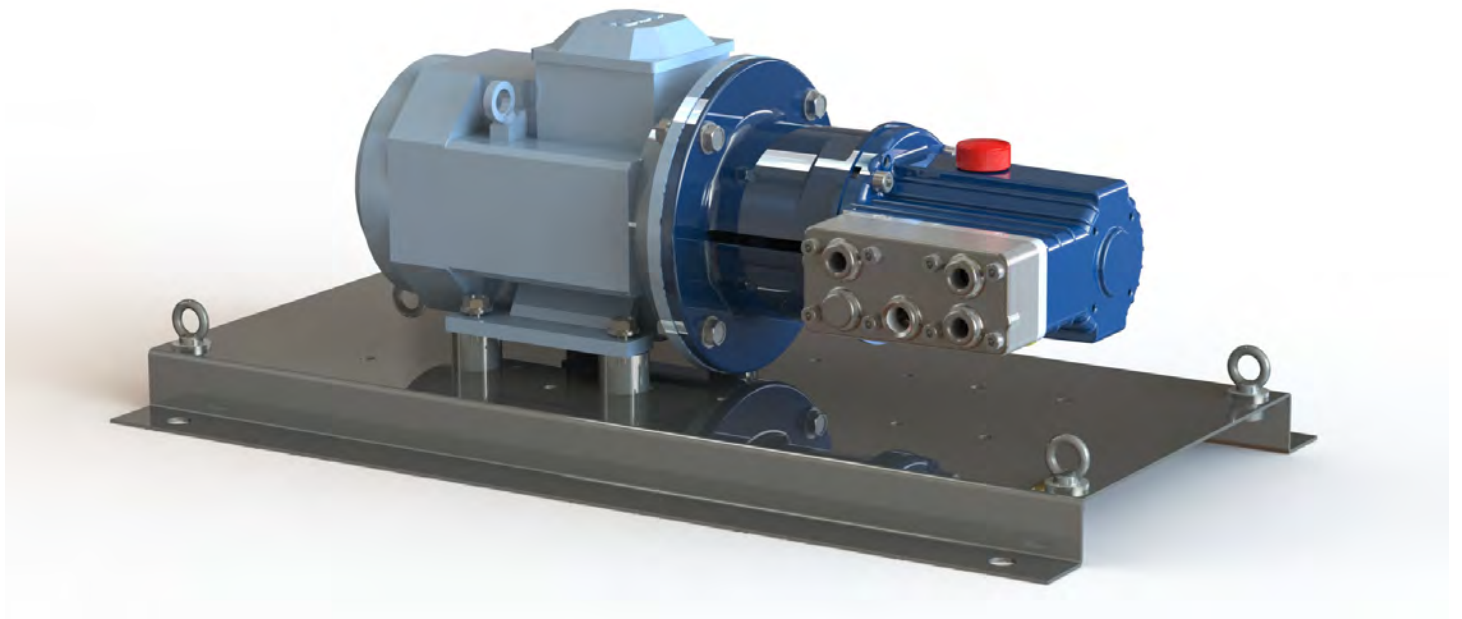

Dimensions in mm

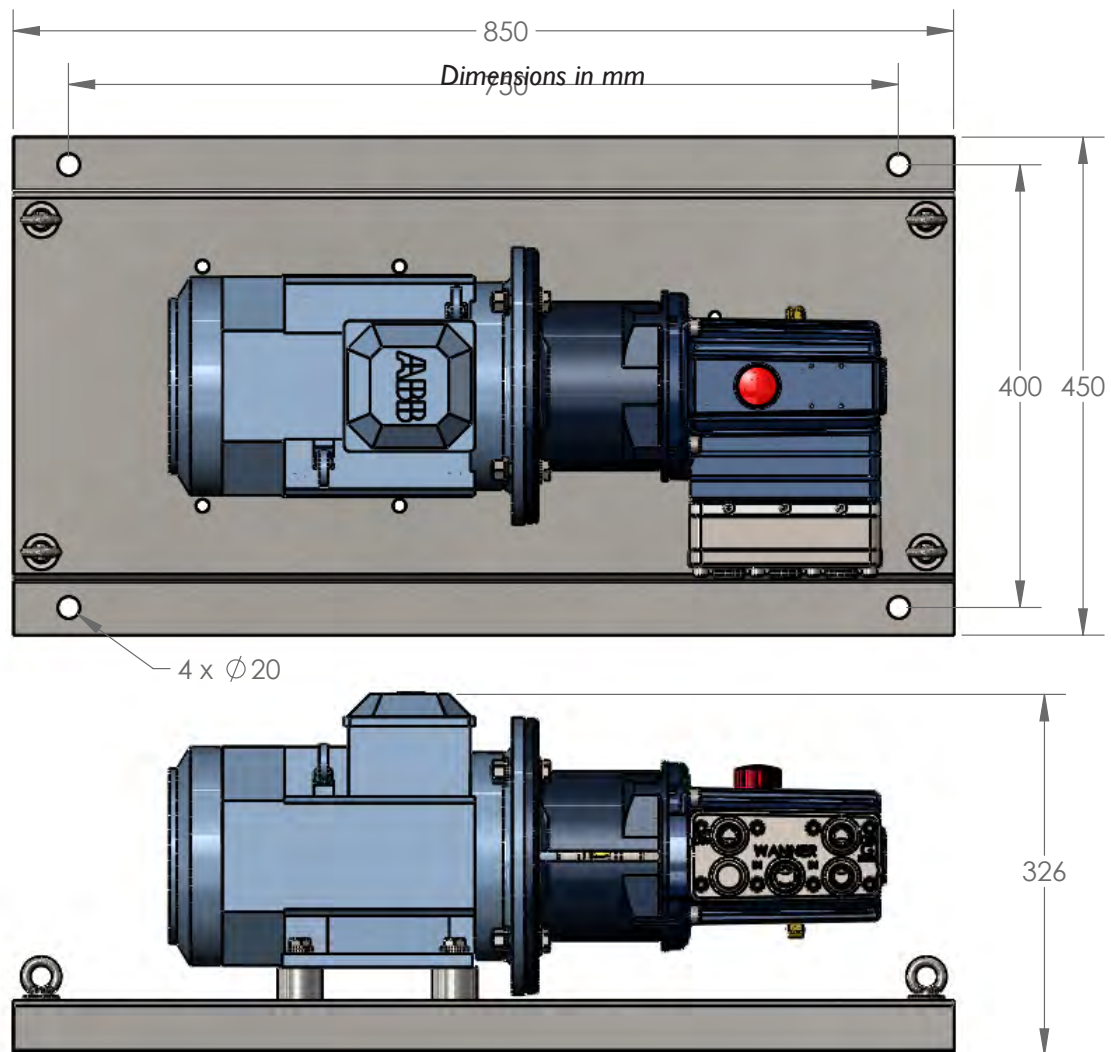

G03 Series General Assemblies

Baseplate Assembly with Motor Adaptor for IEC I32 Motor Frame

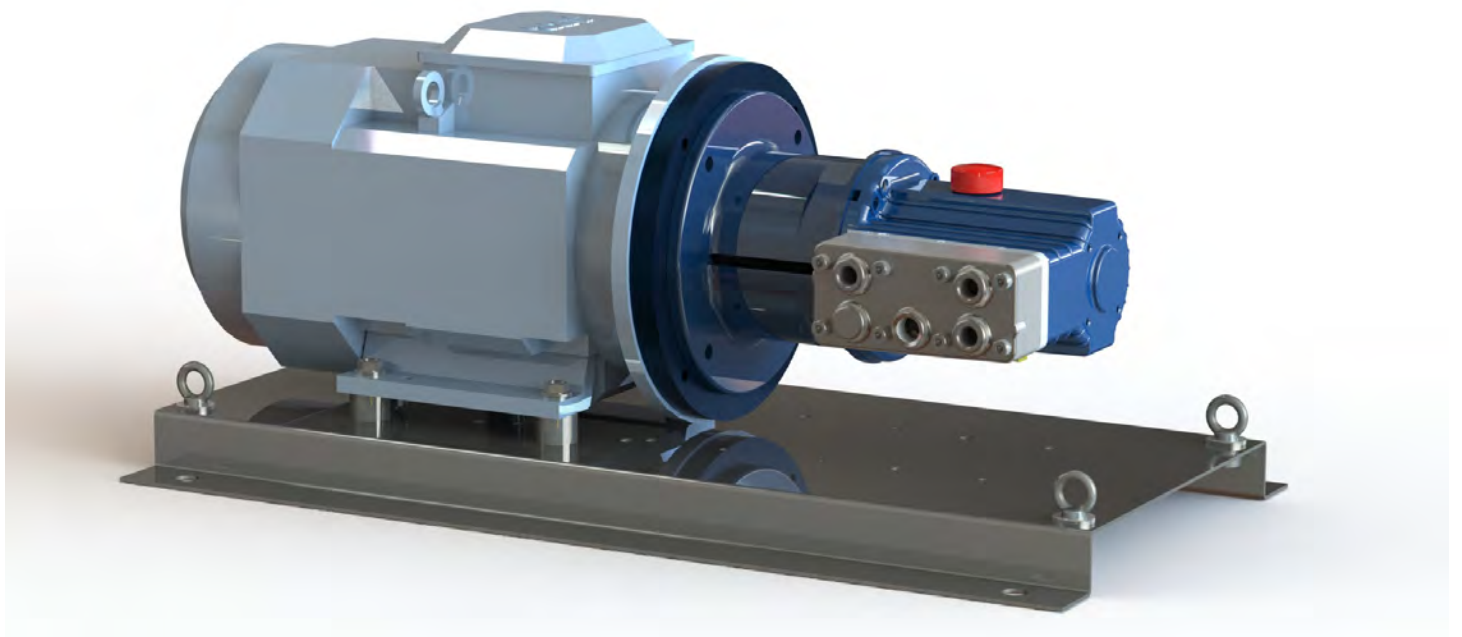

Dimensions in mm

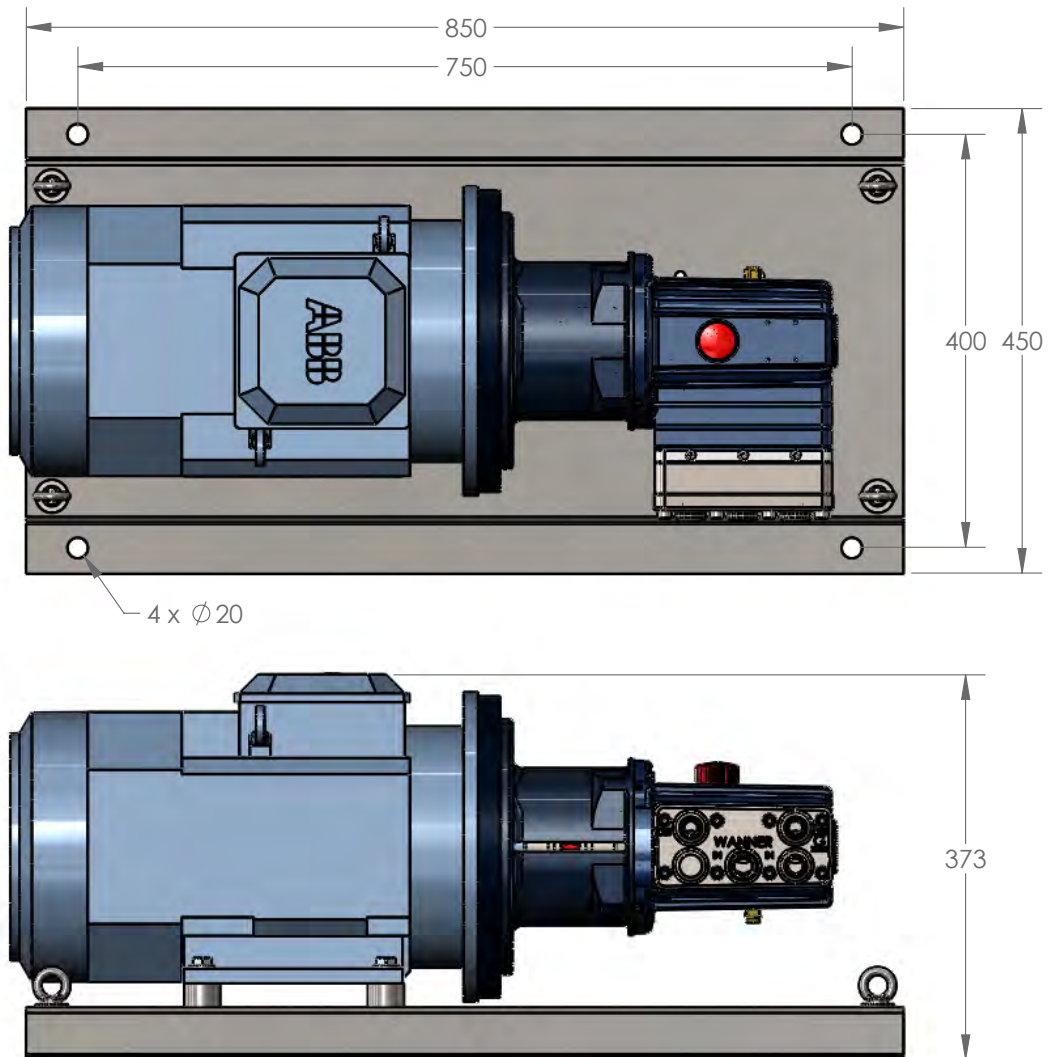

G03 Series Representative Drawings

G13 Models with Metallic Pump Head mm (Inches)

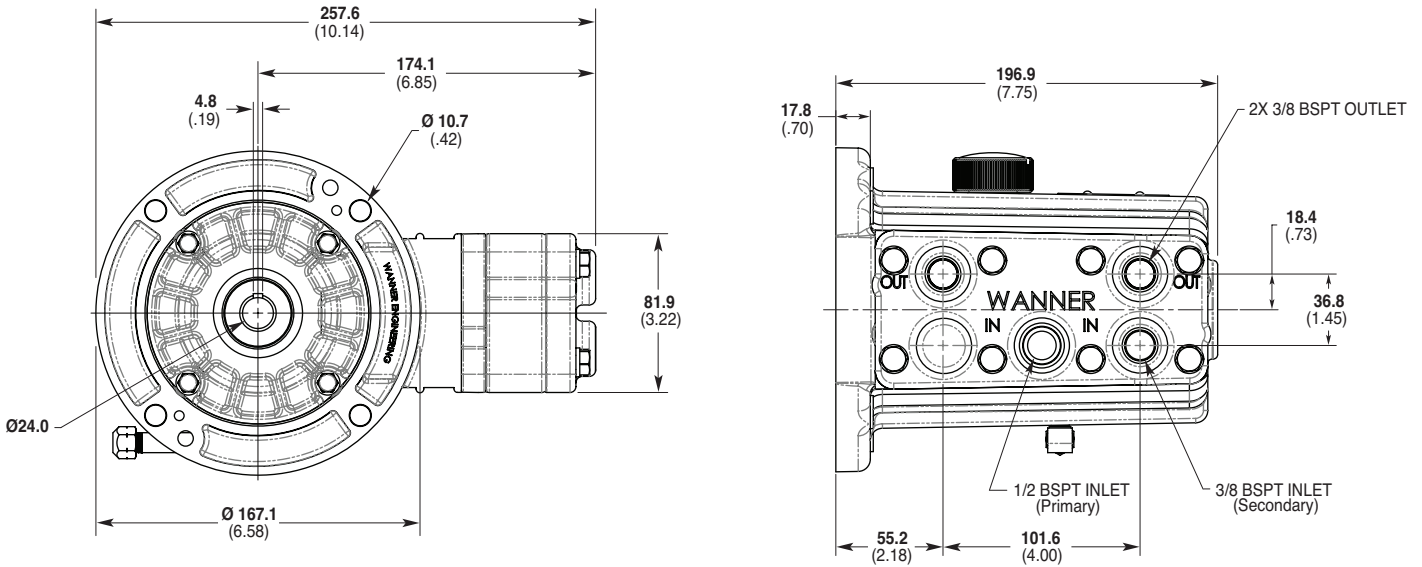

G03 Models with Non-metallic Pump Head mm (Inches)

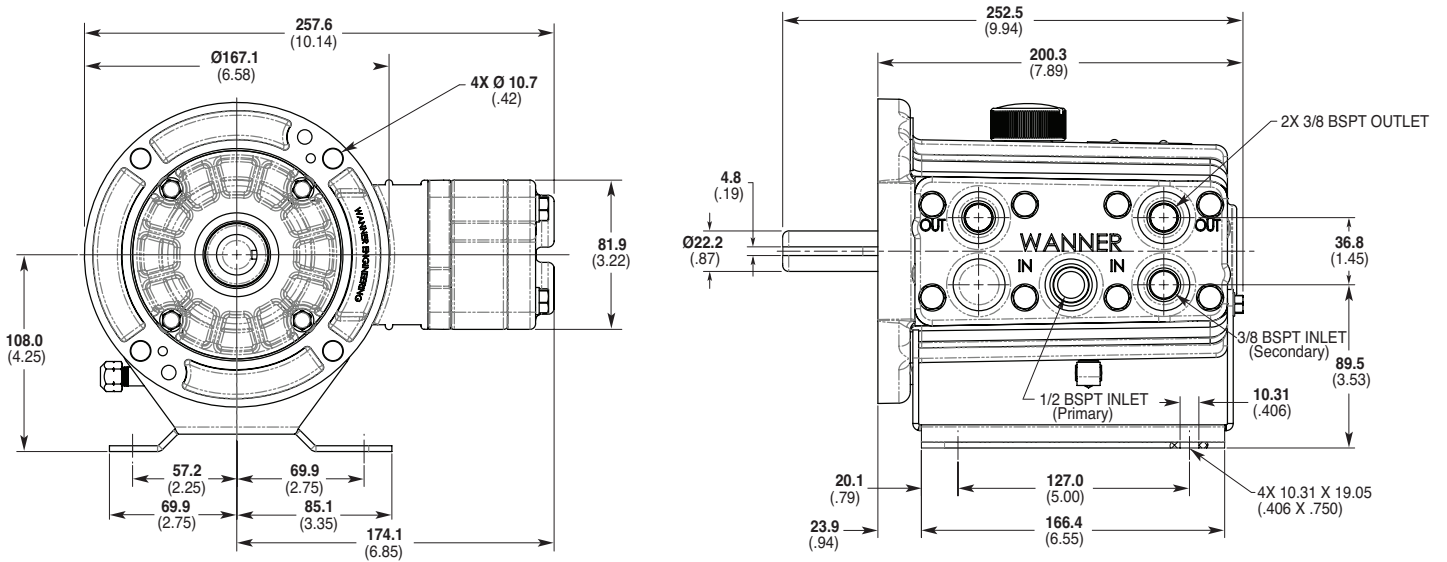

Note: Contact factory for additional drawings of specific models and configurations.

G03 Series Representative Drawings

G03 Models with ANSI RF Flanges mm (Inches)

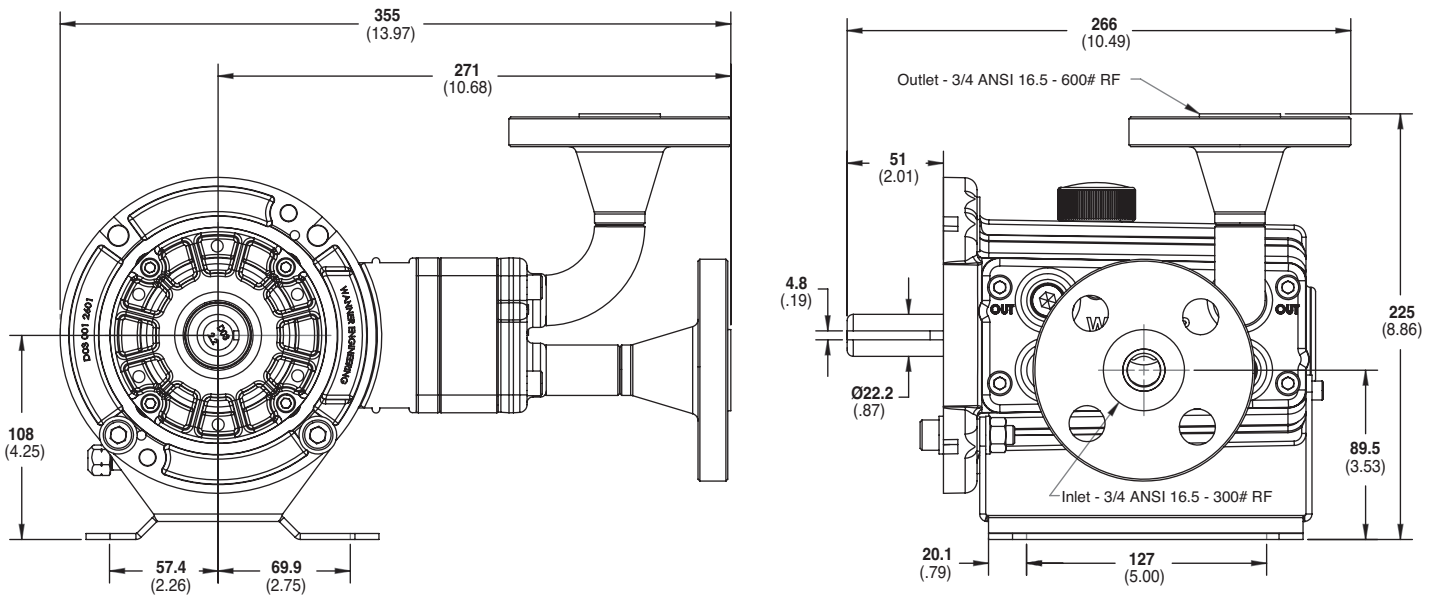

G03 Models with Tri-clamp Flanges mm (Inches)

Maximum Discharge Pressure: 80 bar

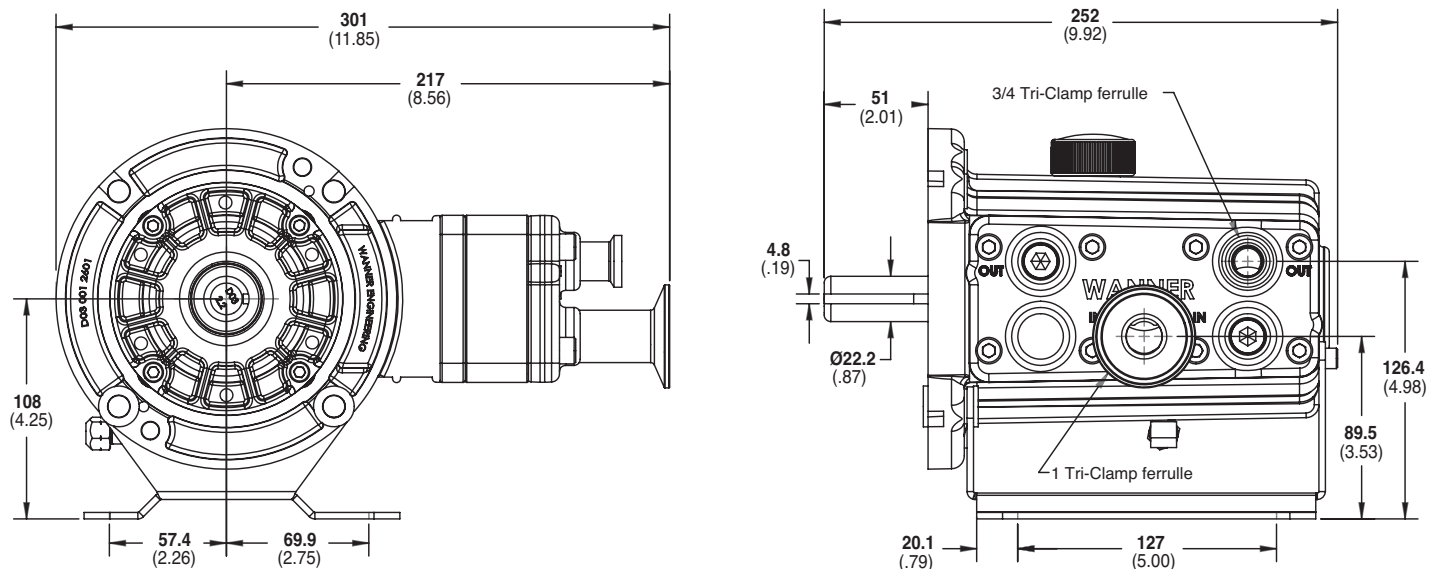

Note: Contact factory for additional drawings of specific models and configurations.

G03 Series Representative Drawings

G03 Models with DIN Flanges mm (Inches)

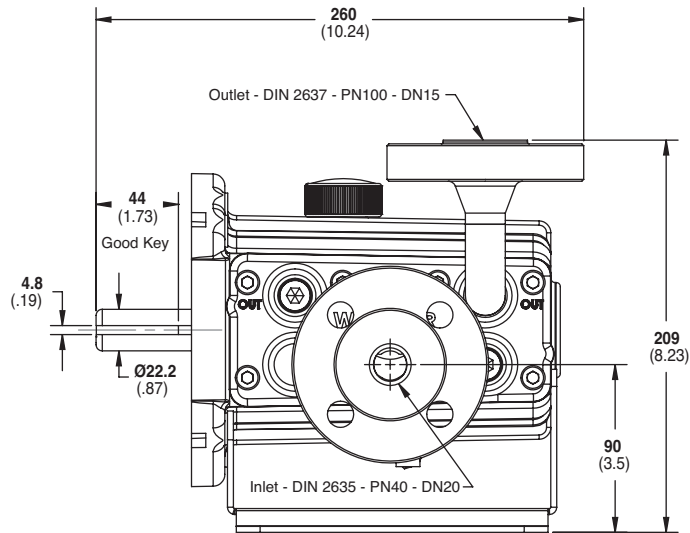
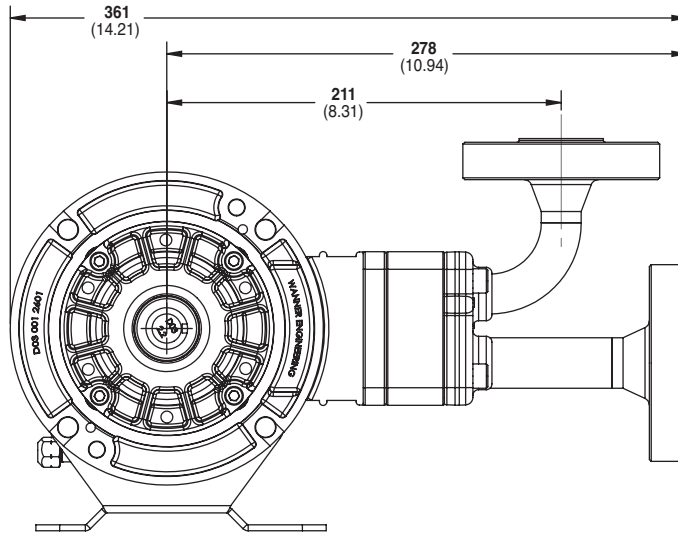

Note: Contact factory for additional drawings of specific models and configurations.

G03 Series Motor Adaptors / Valves

Pump/Motor Adaptor mm (Inches)

Part Number: A04-003-I202

Must be ordered separately for G03 models for use with IEC 80 - 90 frame motors, B5 flange.

NEMA adaptor available - consult factory.

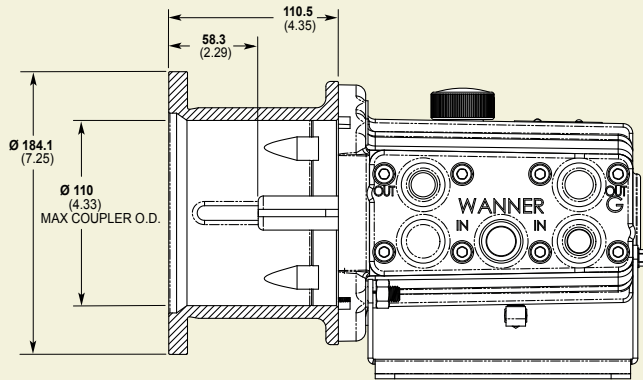

Part Number: A04-004-I202

Must be ordered separately for G03 models for use with IEC 100 - 112 frame motors, B5 flange.

NEMA adaptor available - consult factory.

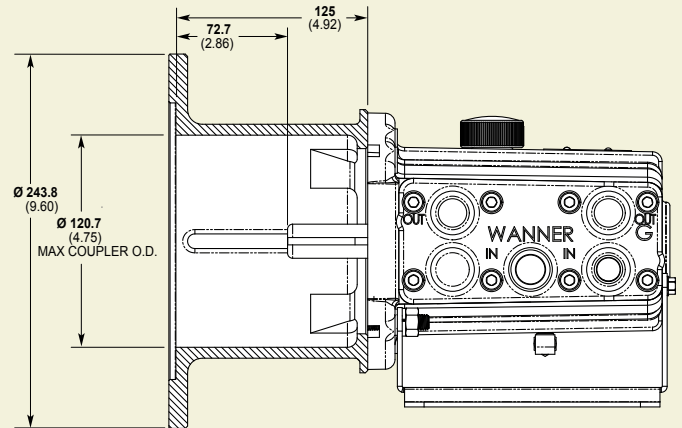

Valve Selection

A Hydra-Cell G03 pumping system uses a C46 Pressure Regulating Valve.



G03 Series **How to Order**

Ordering Information

1	2	3	4	5	6	7	8	9	10	11	12
---	---	---	---	---	---	---	---	---	----	----	----

A complete G03 Series Model Number contains 12 digits including 9 customer-specified design and materials options, for example: G03XKSTHFECA.

Digit	Order Code	Description
1-3	G03	Pump Configuration G03 Shaft-driven (BSPT Ports)*
	G13	G13 Close-coupled to IEC 90 motor (BSPT Ports)*
	-	G13 Option for IEC 80 motor connection (BSPT Ports)
		*Pump/motor adaptors ordered separately. See previous page.
4	X	Hydraulic End Cam Max 9.9 l/min (2.6 gpm) @ 1450 rpm
	E	Max 6.8 l/min (1.8 gpm) @ 1450 rpm
	S	Max 5.6 l/min (1.5 gpm) @ 1450 rpm
	B	Max 3.5 l/min (0.9 gpm) @ 1450 rpm
	G	Max 1.5 l/min (0.4 gpm) @ 1450 rpm
5	D	Pump Head Version Standard BSPT Ports (S, B & G cams)
	K	Kel-Cell BSPT Ports (X & E cams)
	-	ATEX 2014/34/EU Certified, Category 2, Zone 1, Hazardous Liquids
	-	ATEX 2014/34/EU Certified, Category 2, Zone 1, Non-Hazardous Liquids
	-	ATEX 2014/34/EU Certified, Category 3, Zone 2
		<i>Note: All options include Certificate, Oil Level Monitor or Sight Glass, Earth Stud & Secondary ATEX Label.</i>
6	B	Pump Head Material Brass
	M	PVDF
	P	Polypropylene
	R	316L Stainless Steel with ANSI RF Flanges, Class 300lb x 600lb
	-	316L Stainless Steel with DIN Flanges, Class PN40 DN20 x PN100 DN15♦
	S	316L Stainless Steel
	-	316L Stainless Steel with Tri-clamp (1" Inlet & 3/4" Discharge) Flanges polished to 0.8 Ra♦
	-	316L Stainless Steel with Tri-clamp (1" Inlet & 3/4" Discharge) Flanges polished to 0.8 Ra♦
		<i>Tri-clamp options include polishing of Pump Head, Valve Plate, Valves, Valve Seats, Springs & Retainers to 0.8 Ra or 0.4 Ra per above, along with TSE, Passivation, Surface Finish & Weld Procedure Certificates</i>
	T	Hastelloy CW12MW
		♦ Selecting this option will result in a Wanner International generated Pump Code, stamped onto the pump.

Digit	Order Code	Description
7	A	Diaphragm & O-ring Material Aflas diaphragm / PTFE o-ring
	E	EPDM (requires EPDM-compatible oil - Digit 12 oil code J)
	G	FKM
	J	PTFE
	P	Neoprene
	T	Buna-N
8	C	Valve Seat Material Ceramic
	D	Tungsten Carbide
	H	17-4 Stainless Steel
	S	316L Stainless Steel
	T	Hastelloy C
9	C	Valve Material Ceramic
	D	Tungsten Carbide
	F	17-4 Stainless Steel
	N	Nitronic 50
	T	Hastelloy C
10	E	Valve Springs Elgiloy
	S	316L Stainless Steel
	T	Hastelloy C
11	C	Valve Spring Retainers Celcon
	H	17-7 Stainless Steel
	M	PVDF
	P	Polypropylene
	T	Hastelloy C
	Y	Nylon
12	A	Hydra-Oil 10W30 standard-duty oil
	G	5W30 cold-temp severe-duty synthetic oil
	J	20-wt EPDM-compatible oil
	K	Food-contact oil



WANNER
Hydra-Cell[®]
Partners in over 70 Countries

WANNER ENGINEERING - WORLD HEADQUARTERS & MANUFACTURING
Minneapolis USA
t: (612) 332-5681
e: sales@wannereng.com

WANNER PUMPS
Kowloon HONG KONG
t: +852 3428 6534
e: sales@wannerpumps.com

WANNER INTERNATIONAL
Hampshire UK
t: +44 (0) 1252 816847
e: sales@wannerint.com

WANNER ENGINEERING
Latin American Office
t: +55 (11) 4081-7098
e: sales@wannereng.com

WANNER PUMPS
Shanghai CHINA
t: +86-21-6876 3700
e: sales@wannerpumps.com

OFFICIAL UK DISTRIBUTOR:
Michael Smith Engineers Limited
www.michael-smith-engineers.co.uk
freephone: 0800 316 7891

www.hydra-cell.eu