

# H-25-SD/G-25-SD Contents

	Page
Installation .....	2
Maintenance .....	5
Service (Fluid End) .....	6
Service (Hydraulic End) .....	12
Troubleshooting .....	13

**NOTE:** The numbers in parentheses are the Reference Numbers on the illustrations in the Parts Manual.

## H-25-SD/G-25-SD Installation

### Location

Locate the pump as close to the supply source as possible.

Install it in a lighted clean space where it will be easy to inspect and maintain. Allow room for checking the oil level, changing the oil, and removing the manifold support (43), manifold (7), and valve plate (18).

### Mounting

Do not exceed the maximum pump speed. Refer to the Pump Specifications Manual for ratings.

The pump shaft can rotate in either direction.

To prevent vibration, mount the pump securely on a level rigid base.

On a belt-drive system, align the sheaves accurately; poor alignment wastes horsepower and shortens the belt and bearing life. Make sure the belts are properly tightened, as specified by the belt manufacturer.

On a direct-drive system, align the shafts accurately to the specifications of the coupler manufacturer.

### Important Precautions

**Adequate Fluid Supply.** To avoid cavitation and premature pump failure, be sure that the pump will have an adequate fluid supply and that the inlet line will not be obstructed. See "Inlet Piping".

**Positive Displacement.** This is a positive-displacement pump. To avoid severe system damage if the discharge line ever becomes blocked, install a relief valve downstream from the pump. See "Discharge Piping".

**Safety Guards.** Install adequate safety guards over all pulleys, belts, and couplings. Follow all codes and regulations regarding installation and operation of the pumping system.

**Shut-Off Valves.** Never install shut-off valves between the pump and discharge pressure regulator, or in the regulator bypass line.

**Freezing Conditions.** Protect the pump from freezing. See also the Maintenance Section.

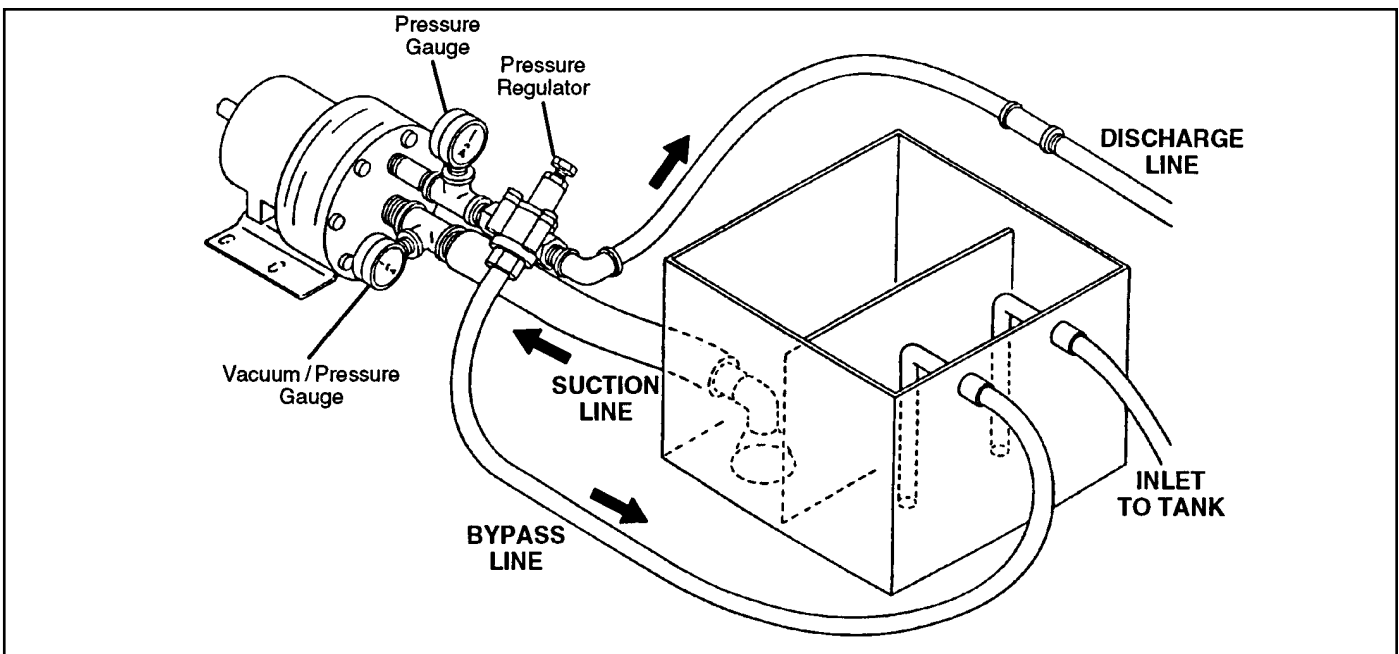

# H-25-SD/G-25-SD Installation

## Inlet Piping (Suction Feed)

**Caution: Do not pump at fluid temperatures above 140° F (60° C). Consult the Pump Specifications Manual for current ratings, based on the pump head material.**

Install draincocks at any low points of the suction line, to permit draining in freezing conditions.

Provide for permanent or temporary installation of a vacuum gauge to monitor the inlet suction. Vacuum at the pump inlet should not exceed **7 in. Hg**.

Do not supply more than one pump from the same inlet line.

Consult the Factory for the following situations:

- Extreme temperature applications — above 120° F (49° C) or below 40° F (4° C)
- Pressure feeding of pumps
- Viscous or extremely abrasive fluid applications
- Chemical compatibility problems
- Hot ambient temperatures — above 100° F (38° C)
- Conditions where pump oil may exceed 180° F (82° C) because of a combination of hot ambient temperatures, hot fluid temperature, and full horsepower load — an oil cooler may be required

## Supply Tank

See the illustration on page 2.

Use a supply tank that is large enough to provide time for any trapped air in the fluid to escape. The tank size should be at least twice the maximum pump flow rate.

Isolate the pump and motor stand from the supply tank, and support them separately.

Install a separate inlet line from the supply tank to each pump.

Install the inlet and bypass lines so they empty into the supply tank below the lowest water level, on the opposite side of the baffle from the pump suction line.

If a line strainer is used in the system, install it in the inlet line to the supply tank.

To reduce aeration and turbulence, install a completely-submerged baffle plate to separate the incoming and outgoing liquids.

Install a vortex breaker in the supply tank, over the outlet port to the pump.

Place a cover over the supply tank, to prevent foreign objects from falling into it.

## Hose Size and Routing

Size the suction line at least one size larger than the pump inlet, and so that the velocity will not exceed 1 to 3 ft/sec (0.3 to 0.9 m/sec):

$$\text{Velocity (ft/sec)} = \frac{0.408 \times \text{GPM}}{\text{Pipe I.D.}^2 *}$$

\*where pipe I.D. is in inches

Keep the suction line as short and direct as possible.

The smallest permissible inlet hose size is:

1 to 10 gpm .....	1-1/2 in. I.D.
11 to 20 gpm .....	2 in. I.D.
1 to 38 liters/min .....	38 mm I.D.
39 to 76 liters/min .....	50 mm I.D.

Use flexible hose and/or expansion joints to absorb vibration, expansion, or contraction.

If possible, keep the suction line level. Do not have any high points to collect vapor unless these high points are vented.

To reduce turbulence and resistance, do not use 90° elbows. If turns are necessary in the suction line, use 45° elbows or arrange sweeping curves in the flexible inlet hose.

If a block valve is used, be sure it is fully opened so that the flow to the pump is not restricted. The opening should be at least the same diameter as the inlet plumbing I.D.

Do not use a line strainer or filter in the suction line unless regular maintenance is assured. If used, it should have a free-flow area of at least three times the free-flow area of the inlet.

Install piping supports where necessary to relieve strain on the inlet line and to minimize vibration. **These supports are essential because the manifold and inlet/outlet adapters are plastic and more susceptible to damage.**

Always tighten all piping connections, gauges, and regulators before installing the piping cluster into the pump manifold.

## Inlet Piping (Pressure Feed)

Provide for permanent or temporary installation of a vacuum/pressure gauge to monitor the inlet vacuum or pressure. Pressure at the pump inlet should not exceed 50 psi (345 kPa); if it could get higher, install an inlet pressure regulator.

Do not supply more than one pump from the same inlet line.

Always tighten all piping connections, gauges, and regulators before installing the piping cluster into the pump manifold.

# H-25-SD/G-25-SD Installation

## Inlet Calculations

### Acceleration Head

#### Calculating the Acceleration Head

Use the following formula to calculate acceleration head losses. Subtract this figure from the NPSHa, and compare the result to the NPSHr of the Hydra-Cell pump.

$$H_a = (L \times V \times N \times C) \div (K \times G)$$

where:

$H_a$  = Acceleration head (ft of liquid)

$L$  = Actual length of suction line (ft) — not equivalent length

$V$  = Velocity of liquid in suction line (ft/sec) [ $V = \text{GPM} \times (0.408 \div \text{pipe ID}^2)$ ]

$N$  = RPM of crank shaft

$C$  = Constant determined by type of pump — use 0.066 for the H-25-SD and G-25-SD Hydra-Cell pumps

$K$  = Constant to compensate for compressibility of the fluid — use: 1.4 for de-aerated or hot water; 1.5 for most liquids; 2.5 for hydrocarbons with high compressibility

$G$  = Gravitational constant (32.2 ft/sec<sup>2</sup>)

### Friction Losses

#### Calculating Friction Losses in Suction Piping

When following the above recommendations (under “Inlet Piping”) for minimum hose/pipe I.D. and maximum length, frictional losses in the suction piping are negligible (i.e.,  $H_f = 0$ ) if you are pumping a water-like fluid.

When pumping more viscous fluids such as lubricating oils, sealants, adhesives, syrups, varnishes, etc., frictional losses in the suction piping may become significant. As  $H_f$  increases, the available NPSH (NPSHa) will decrease, and cavitation will occur.

In general, frictional losses increase with increasing viscosity, increasing suction-line length, increasing pump flowrate, and decreasing suction-line diameter. Changes in suction-line diameter have the greatest impact on frictional losses; a 25% increase in suction-line diameter cuts losses by more than two times, and a 50% increase cuts losses by a factor of five times.

Use one of the following formulas to calculate friction losses in your system. Subtract the resulting figure from the NPSHa, and compare the result to the NPSHr of the Hydra-Cell pump.

**For flowrates of 1 to 10 gpm, use:**

$$H_f = 0.38 \text{ ft} \times \frac{\text{CPS}}{100} \times \frac{\text{GPM}}{10} \times \frac{L}{3} \times \left(\frac{1.5}{\text{ID}}\right)^4$$

**For flowrates of 11 to 20 gpm, use:**

$$H_f = 0.25 \text{ ft} \times \frac{\text{CPS}}{100} \times \frac{\text{GPM}}{20} \times \frac{L}{3} \times \left(\frac{2}{\text{ID}}\right)^4$$

where:

CPS = Viscosity of pumped material (in centipoise)

$L$  = Length of suction line (in feet), and

ID = Pipe I.D. (in inches)

### Minimizing Acceleration Head and Frictional Losses

To minimize the acceleration head and frictional losses:

- Keep inlet lines less than 3 ft (1 m) long
- Use at least 1-1/2 in. (38 mm) I.D. inlet hose
- Use soft hose (low-pressure hose, noncollapsing) for the inlet lines
- Minimize fittings (elbows, valves, tees, etc.)
- **Use a suction stabilizer on the inlet.**

### Net Positive Suction Head

NPSHa must be equal to or greater than NPSHr. If not, the pressure in the pump inlet will be lower than the vapor pressure of the fluid— and cavitation will occur.

#### Calculating the NPSHa

Use the following formula to calculate the NPSHa:

$$\text{NPSHa} = P_t + H_z - H_f - H_a - P_{vp}$$

where:

$P_t$  = Atmospheric pressure

$H_z$  = Vertical distance from surface liquid to pump centerline (if liquid is below pump centerline, the  $H_z$  is negative)

$H_f$  = Friction losses in suction piping

$H_a$  = Acceleration head at pump suction

$P_{vp}$  = Absolute vapor pressure of liquid at pumping temperature

NOTES:

- In good practice, NPSHa should be 2 ft greater than NPSHr
- All values must be expressed in feet of liquid

#### Atmospheric Pressure at Various Altitudes

Altitude (ft)	Pressure (ft of H <sub>2</sub> O)	Altitude (ft)	Pressure (ft of H <sub>2</sub> O)
0	33.9	1500	32.1
500	33.3	2000	31.5
1000	32.8	5000	28.2

## Discharge Piping

**NOTE: Consult the Factory before manifolding two or more pumps together.**

### Hose and Routing

Size the discharge line one or two sizes larger than the pump discharge opening. Use the shortest, most direct route.

Size the discharge line so that the velocity will not exceed 7 - 10 ft/sec (2 to 3 m/sec):

$$\text{Velocity (ft/sec)} = \frac{0.408 \times \text{GPM}}{\text{Pipe I.D.}^2}$$

\*where pipe I.D. is in inches

# H-25-SD/G-25-SD Installation

The smallest permissible discharge hose size is:

1 to 10 gpm .....	11/16 (0.687) in. I.D.
11 to 20 gpm .....	1 in. I.D.
1 to 38 liters/min .....	17 mm I.D.
39 to 76 liters/min .....	25 mm I.D.

Use flexible hose between the pump and hard piping, to absorb vibration, expansion, or contraction.

Never install a shutoff valve in the discharge line between the pump and the regulator, or in the bypass line.

Select pipe or hose with a working pressure rating of at least 1.5 times the maximum system pressure. Example: Select a 300-psi W.P.-rated hose for systems to be operated at 200-psi-gauge pressure.

Support the pump and piping independently. **These supports are essential, because the manifold and inlet/outlet adapters are plastic and more susceptible to damage.**

## Pressure Regulation

**Install a pressure regulator or unloader in the discharge line.** Bypass pressure must not exceed the pressure limit of the pump.

Size the regulator so that, when fully open, it will be large enough to relieve the full capacity of the pump without overpressurizing the system.

Locate the valve as close to the pump as possible and ahead of any other valves.

Adjust the pressure regulating valve to no more than 10% over the maximum working pressure of the system. Do not exceed the manufacturer's pressure rating for the pump or regulator.

Route the bypass line to the supply tank, or to the suction line as far as possible from the pump (to reduce the chance of turbulence).

If the pump will be operating for a long time with the discharge closed and fluid bypassing, install a thermal protector set to trip at 120° F (49° C) in the bypass line — to prevent severe temperature buildup in the bypassed fluid.

**Caution: Never install shutoff valves in the bypass line or between the pump and pressure regulator or relief valve.**

Provide for permanent or temporary installation of a pressure gauge to monitor the discharge pressure at the pump.

For additional system protection, install a "pop-off" safety relief valve in the discharge line, downstream from the pressure regulator.

Always tighten all piping connections, gauges, and regulators before installing the piping cluster into the pump manifold.

## Before Initial Start-Up

Before you start the pump, be sure that:

- All shut-off valves are open, and the pump has an adequate supply of fluid.
- All connections are tight.
- The oil level is approximately 1 in. (2.5 cm) from the top of the fill port — so that the floor of the upper reservoir within the pump housing is flooded and the chamber itself is about 1/4 full, allowing for oil expansion as the pump runs and heats up.
- The relief valve on the outlet of the pump is adjusted so the pump starts under minimum pressure.
- All pulleys and belts are properly aligned, and belts are tensioned according to specification.
- All pulleys and belts have adequate safety guards.

## Initial Start-Up Procedure

1. Turn on power to the pump motor.
2. Check the inlet pressure or vacuum. Inlet vacuum must not exceed 7 in. Hg at 70° F (180 mm Hg at 21° C). Inlet pressure must not exceed 50 psi (345 kPa).
3. If you hear any erratic noise or if the flow is unsteady, refer to the Troubleshooting Section.
4. If the system has an air lock and the pump fails to prime:
  - a. Turn off the power.
  - b. Remove the drain plug (4) on the bottom center of the manifold.

**Note: Fluid may come out of this port when the plug is removed. Provide an adequate catch basin for fluid spillage, if required. Fluid will come out of this port when the pump is started, so we recommend that you attach adequate plumbing from this port so fluid will not be sprayed or lost. Use high-pressure-rated hose and fittings from this port. Take all safety precautions to assure safe handling of the fluid being pumped.**

  - c. Jog the system on and off until the fluid coming from this port is air-free.
  - d. Turn off the power.
  - e. Remove the plumbing that was temporarily installed, and reinstall the drain plug (4).
5. Adjust the discharge pressure regulator to the desired operating and bypass pressures.
6. After the pressure regulator is adjusted, set the "pop-off" safety relief valve at 100 psi (690 kPa) higher than the desired operating pressure. To verify this setting, adjust the discharge pressure regulator upward until the relief valve opens. Follow the recommendations in the above Note (Step 4b) for handling the fluid that will come from the relief valve.
7. Reset the discharge pressure regulator to the desired system pressure.
8. Provide a return line from the relief valve to the supply tank, similar to the bypass line from the pressure regulator.