

I Application

The NLS valve is an overflow pneumatically actuated single seat valve designed for the dairy and food-processing industries, beverage production, pharmaceutical and fine chemicals industries. It is widely used as a bypass valve for the positive displacement pumps, it is also used to protect the equipment in case of excessive pressure.

I Operating principle

The spring pressure forces the valve to close, the pressure can be adjusted by a screw on the top of the valve. When the configured pressure is exceeded, the valve opens. The valve is provided with a pneumatic seat lift, it allows the CIP liquid pass through during the CIP process.

I Design and features

- 360° adjustable body.
- Compact design.
- Pneumatic seat lift.
- Pressure range: 0,5 - 6 bar.
- Weld connections.
- Clamp facilitates assembly/disassembly of the internal parts.

I Materials

Parts in contact with the product	AISI 316L
Other stainless steel parts	AISI 304
Gaskets	EPDM according to FDA 177.2600
Internal surface finish	Ra ≤ 0,8 μm
External surface finish	bright polish

I Options

- Steam barrier (if shaft sterilisation is required).
- Jacketed body.
- Spring: up to 10 bar for DN 25, 40 and 50 valves.
- Internal surface finish: Ra ≤ 0,5 μm.
- Gaskets: NBR or FPM.
- Connections: DIN, Clamp, SMS, RJT, FIL-IDF, etc.



I Technical specifications

Available sizes	DN 25 - DN 80	DN 1" - DN 3"
Working temperature	-10 °C to +120 °C (EPDM)	14 °F to 248 °F
	+140 °C (SIP, max. 30 min)	284 °F
Maximum working pressure	10 bar	145 PSI
Minimum working pressure	Vacuum	
Maximum opening pressure	6 bar	87 PSI
Minimum opening pressure	0.5 bar	7 PSI
Compressed air pressure	6-8 bar	87-116 PSI
Air supply connections	G1/8" (BSP)	

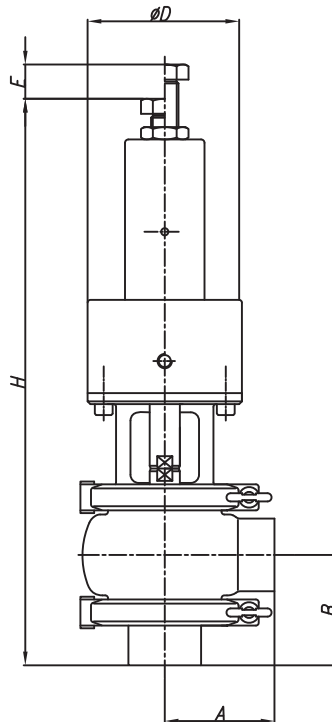

DN	A	B	E	D	H	
25	1"	50	55	35	86	325
40	1½"	60	65	35	86	345
50	2"	70	80	25	112	405
65	2½"	80	90	35	145	415
80	3"	90	100	35	145	455



The information is for guidance only. We reserve the right to modify any material or feature without notice in advance. Photos are not binding. For further information, please, consult our web site. www.inoxpa.com



FT.NLS.2-EN-0913