

I Application

The TLS pump is a positive displacement rotary lobe pump designed according to the sanitary requirements. The pump has a reduced size and it is highly efficient and reliable. This pump is ideal for managing all kinds of fluid, of either low or high viscosity, in the food-processing, dairy and cosmetic industries as well as for filtering and bottling applications. Products containing fragile solids such as junket can be pumped without damage thanks to the specially designed lobes.

I Design and features

The TLS pump is a monoblock pump that can be adapted to any gear motor with a B5 flange. The pump basically consists of a stainless steel pump housing and cover manufactured by investment casting, two tri-lobe rotors with a sanitary design attachment. Moreover, the pump is provided with height adjustable stainless steel legs of hygienic design.

The rotary lobe pump is provided with a C/SiC/EPDM external single mechanical seal. The seal is balanced and has a sanitary design. If an application requires it, other seal materials can be used.

I Technical specifications

Materials:

Parts in contact with the product	AISI 316L (1.4404)
Other stainless steel parts	AISI 304L (1.4306)
Support and lantern	GG-25
Gaskets in contact with the product	EPDM according to FDA

Mechanical seal:

Rotary part	Silicon carbide (SiC)
Stationary part	Carbon (C)
Gaskets	EPDM

Internal surface finish:	Bright polish, Ra < 0,8 µm
External surface finish:	Bright

Connections:	DIN 11851 CLAMP SMS
--------------	---------------------------

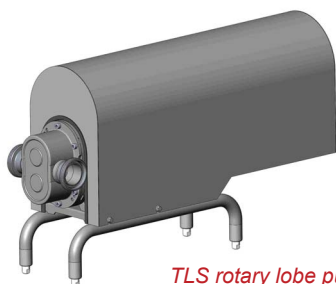

TLS rotary lobe pump
with shroud



I Technical specifications

Operating limits:

Nominal pressure	1200 kPa (12 bar)	174 PSI
Temperature range	-10 to 120 °C (EPDM)	14°F to 248°F
	+140°C (SIP, max. 30 min.)	284°F

	DN	Maximum speed min ⁻¹	Maximum pressure bar	Volume per revolution l/rev.
TLS 1-25	25 1"	950	12	0,10
TLS 1-40	40 1½"	950	7	0,14
TLS 2-40		950	12	0,23
TLS 2-50	50 2"	950	7	0,30
TLS 3-50		720	12	0,68
TLS 3-80	80 3"	720	7	0,95

I Motor and gear unit

Helical gear unit with B5 flange in compliance with the IEC standards and triphasic induction motor 4 poles=1500/1750 rpm, IE-2 efficiency class, IP 55 protection and F-class insulation.

3 phases, 50 Hz, 220-240 V Δ / 380-420 V Y, ≤ 4 kW
 3 phases, 50 Hz 380-420 V Δ / 660-690 V Y, ≥ 5,5 kW

I Options

- Pump casing with drain port.
- Mechanical seal options: SiC/SiC, TgC/SiC, C/StSt.
- Lip seal.
- FPM gaskets.
- External by-pass.
- Bi-lobe rotors.
- Stainless steel shroud can be mounted without disassembling the pump.
- Other drive types and protection classes.
- Different types of connections.
- Stainless steel trolley.
- Polyester or stainless steel control box.



I Dimensions

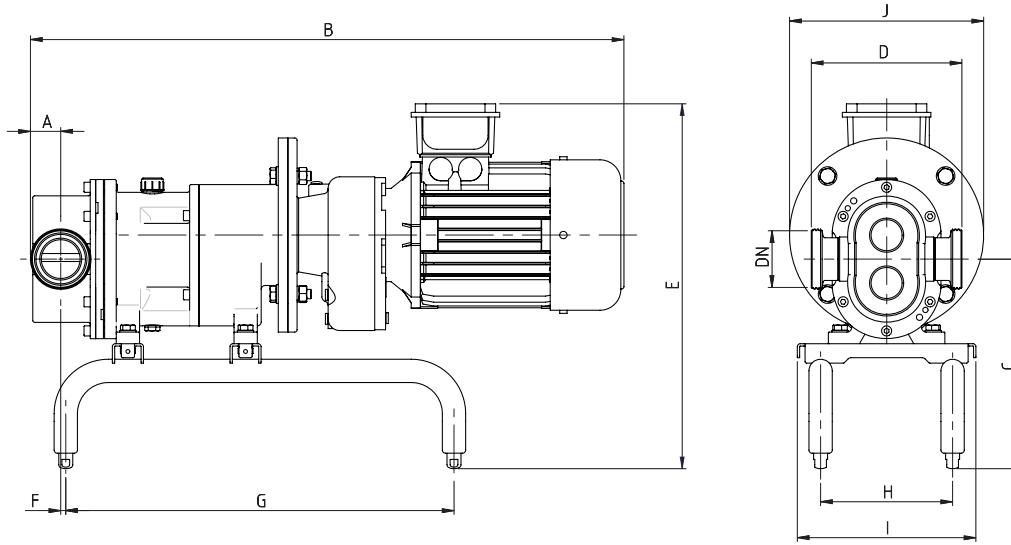

	DN	D		
		DIN 11851	SMS	CLAMP
TLS 1-25	25 1"	158	138	156
TLS 1-40	40 1½"	166	146	
TLS 2-40		190	170	180
TLS 2-50	50 2"	194		
TLS 3-50		239	215	225
TLS 3-80	80 3"	256	223	227



The information is for guidance only. We reserve the right to modify any material or feature without notice in advance. Photos are not binding. For further information, please, consult our web site. www.inoxpa.com



FT.TLS.2.EN-0914

I Dimensions

	Gear unit	kW	DN	A	B	C	E	F	G	H	I	J	kg
TLS 1-25	SK01F	0,55	25	26	625	220	387	2	375	140	200	165	36
		0,75	25	26	625	220	387	2	375	140	200	165	39
TLS 1-40	SK01F	0,75	40	33	640	220	387	8	375	140	200	165	40
		1,1	40	33	675	220	392	8	375	140	200	185	44
TLS 2-40	SK20F	1,1	40	33	725	270	448	1	500	170	230	200	59
		1,5	40	33	725	270	448	1	500	170	230	200	63
TLS 2-50	SK20F	1,5	50	39	735	270	448	6	500	170	230	200	64
		2,2	50	39	765	270	470	6	500	170	230	200	74
TLS 3-50	SK25F	2,2	50	39	880	353	569	-13	600	200	280	250	121
		3	50	39	880	353	569	-13	600	200	280	250	121
		4	50	39	925	353	579	-13	600	200	280	250	126
TLS 3-50	SK33F	5,5	50	39	1010	353	604	-13	600	200	280	300	156
TLS 3-80	SK25F	3	80	55	905	353	569	-2	600	200	280	250	124
		4	80	55	955	353	579	-2	600	200	280	250	130
TLS 3-80	SK33F	5,5	80	55	1035	353	604	-2	600	200	280	300	159
		7,5	80	55	1035	353	604	-2	600	200	280	300	166



The information is for guidance only. We reserve the right to modify any material or feature without notice in advance. Photos are not binding. For further information, please, consult our web site. www.inoxpa.com



FT.TLS.2.EN-0914