

Product Range

Company, Technology & Applications



NETZSCH Group



NETZSCH Group

The Gebrüder NETZSCH Maschinenfabrik (NETZSCH Brothers Machine Works), founded in 1873, was the starting point for today's NETZSCH Group still head-quartered in Selb, Germany, which has since become an international family-owned enterprise with over 3.000 employees working at 163 locations in nearly 28 countries on five continents.

The three Business Units, Analyzing & Testing, Grinding & Dispersing and Pumps & Systems, operate independently with the goal to offer the customer the best solution for his particular application. The result of over 140 years of engineering experience is both technological and market leadership.

NETZSCH Holding

Under the umbrella of the Erich NETZSCH GmbH & Co. Holding KG, the synergies between the Business Units are ensured through worldwide communication.

The NETZSCH Holding builds the bridge between the shareholder family and the business units and is mainly involved in the group strategy and the financial management.

Table of Contents

NETZSCH Group.....	2
Business Unit Pumps & Systems.....	4
Technology & Product Management.....	8
Business Fields.....	10
NEMO® Progressing Cavity Pumps – Features and Design	12
NEMOLAST® – Optimised Elastomer Qualities.....	14
TORNADO® Rotary Lobe Pumps – Features and Design.....	16
NOTOS Multiple Screw Pumps.....	20
NETZSCH Dosing Technolog.....	26
NETZSCH Grinder	28
Accessories & Service	30

Pumps & Systems Business Unit



Pumps and system have been manufactured at the Waldkraiburg site for 60 years. The site is also the headquarters of the Business Unit.

Experts in Pump Solutions for 60 Years

For more than six decades, NETZSCH has manufactured positive displacement pumps worldwide. Designed specifically for difficult pumping situations, NETZSCH pumps range in size from the industry's smallest metering pumps to high volume pumps for applications in the oil and gas or mining industries.

In 1951, the NETZSCH Group acquired the Progressing Cavity Pump license to manufacture and distribute NEMO® progressing cavity pumps according

to the Moineau pump system. NEMO® received its name from this system invented by Professor René Moineau: NETZsch + MOineau = NEMO®.

Since 2002, NETZSCH has also successfully developed and marketed rotary lobe pumps for a constantly growing number of applications under the TORNADO® brand name. The second TORNADO® generation, the T2, was introduced in 2012 and revolutionised the performance and potential of the rotary lobe pump with its new design.

The NETZSCH pump product range has three product lines:

NEMO® progressing cavity pumps, **TORNADO®** rotary lobe pumps and **NOTOS** multiple screw pumps.

Each of our type of rotating displacement pump ensures the following:

- the medium is conveyed with low shearing rates
- the medium is dosed with low pulsation, accurately and reliably
- the volumetric flow is conveyed irrespective of solid content
- the volumetric flow is conveyed proportionally to the speed
- highly viscous and solid-containing media are conveyed
- the pumps are self-priming
- non-vapor and air locking operation
- low noise levels
- flexible operation and mounting options
- no blockages occur thanks to the valve-free design

Every NEMO® pump from NETZSCH can be configured using a modular system that allows a large selection of different materials to be combined for pump housing, stator and rotor, geometries, joints and seals.

Our experience developing and manufacturing displacement pumps is also reflected in the TORNADO® rotary lobe pump. The pump is the ideal complement to our NEMO®

product line and is perfect in particular for space-saving installation, as a mobile pump and for applications with moderate to high flow rates at moderate pressures. It has a compact design and is a very efficient pump.

The NOTOS multiple screw pump is suitable for low to high viscosity as well as blunt and lubricant media. It provides the necessary water pressure for the impression osmosis or is used for the supply of oil in hydrostatic bearings as they are needed, for it example in hydropower stations for adjusting the turbine blades.

All NETZSCH pumps can be used in a wide range of applications. The following are a few examples:

- Bonding and sealing
- Chemical
- Dosing
- Environmental technology
- Food and drink
- Marine industry
- Mining
- Oil & gas production and transfer
- Paints and lacquers
- Paper industry
- Pharmaceuticals and cosmetics
- Renewable energies
- Water and waste water treatment

NETZSCH pumps are made both at our headquarters in Germany and also at our production sites in Brazil, China, India and the USA. Sales offices in many European countries, Africa and the United Arab Emirates, as well as on the Asian continent, in Australia and the Americas market are selling the pumps near by the customer. NETZSCH NEMO® progressing cavity and TORNADO® rotary lobe pumps. Our M-Ovas®, twin shaft macerators and dosing technology products round off the range as well as accessories and our competent service network worldwide.

Pumps & Systems Business Unit

Development, Production, Sales & Sites

Europe, Middle East, Africa

NETZSCH Pumpen & Systeme GmbH Waldkraiburg, Germany



Central and South America

NETZSCH do Brasil Ltda. Pomerode, Brasil



Our product range

For six decades we've been supplying worldwide NEMO® progressing cavity pumps, TORNADO® rotary lobe pumps, NOTOS screw pumps, macerators/ grinders, dosing systems and equipment for custom built and challenging solutions for your applications.

Our production

With a production of over 50,000 pumps per year we underline our technology and market leadership, which we have gained thanks to the quality of our pumps and spare parts. It is guaranteed by the core competence and a high level of vertical manufacturing which we have built up over the many years.

Our core expertise

Elastomer research & development and production is in-house at NETZSCH. The elastomers marked under the NEMOLAST® brand name for stators, rotary lobes and housing inserts are optimised for the specific application. NETZSCH also develops and manufactures rotors in various geometries, made of various metallic and ceramic materials for optimum performance and service life.

USA and Canada

NETZSCH Pumps North America, LLC, USA



Asia and Pacific

NETZSCH Lanzhou Pumps Lanzhou, China



NETZSCH Technologies India Private Ltd., India

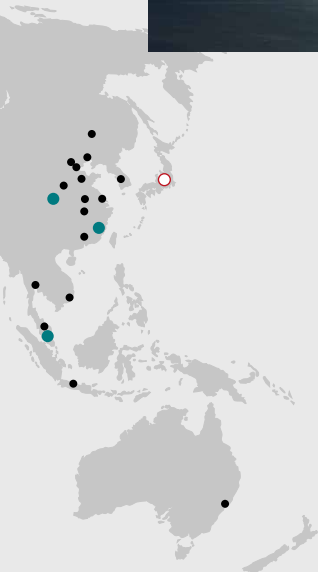

- Development & Production Sites
- International Sales and Service Companies
- Co-operation partner HEISHIN Ltd., Japan

Our quality

With the worldwide implementation of common standards in accordance with DIN EN ISO 9001 in development and research we guarantee the highest quality at each production site.

Our sites

With more than 2,000 employees at five development and production sites as well as 30 sales offices, a co-operation partner (in Japan) and another 200 NETZSCH representatives we are close to you wherever you are.

Our strategy

Our development and sales activities are focused on trend-setting technologies and applications, to expand our market and technology leadership for the benefit of our customers. Hereby we don't see ourselves only as a developer and manufacturer, but more as your partner from project planning through case management to complete service concepts.

Technology & Product Management – The Perfect Allies for Innovation

NEMO CERATEC®
1997



Modification of the NM series
TORNADO® rotary lobe pump
2002

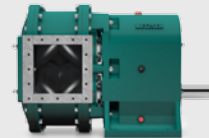

2000
NETZSCH dosing and
barrel emptying systems



2005
M.Champ®
M-Ovas®



Strategy

Regular innovations are the key to long-term market leadership. But only innovations relevant to the market are successful, because they meet the current needs of customers. That is why innovations are a pillar of the NETZSCH strategy that supports the ongoing growth of the company.

Tools

We successfully use a range of tools to generate innovations, including the Contradiction Oriented Innovation Strategy (WOIS) innovation method or open innovations (e.g. the lead-user method). We also use a number of software tools (FEM, CFD, modal analysis etc.) and have set up modern technical laboratories with the latest test stands at all production sites to test our newly developed products and components. Overall 120 employees worldwide are involved in research and development of new products.

Intellectual property

Innovations have to be protected if the cost of development is going to contribute to a stronger position on the market. The financial cost is only justifiable from an economic point of view if that is the case – and it is the only way to confront copycats. The NETZSCH Group patent department therefore applies for patents every year globally and defends our trademark rights in all countries in which NETZSCH sells its products. NETZSCH has successfully established more than a dozen innovations on the market over the last 20 years.



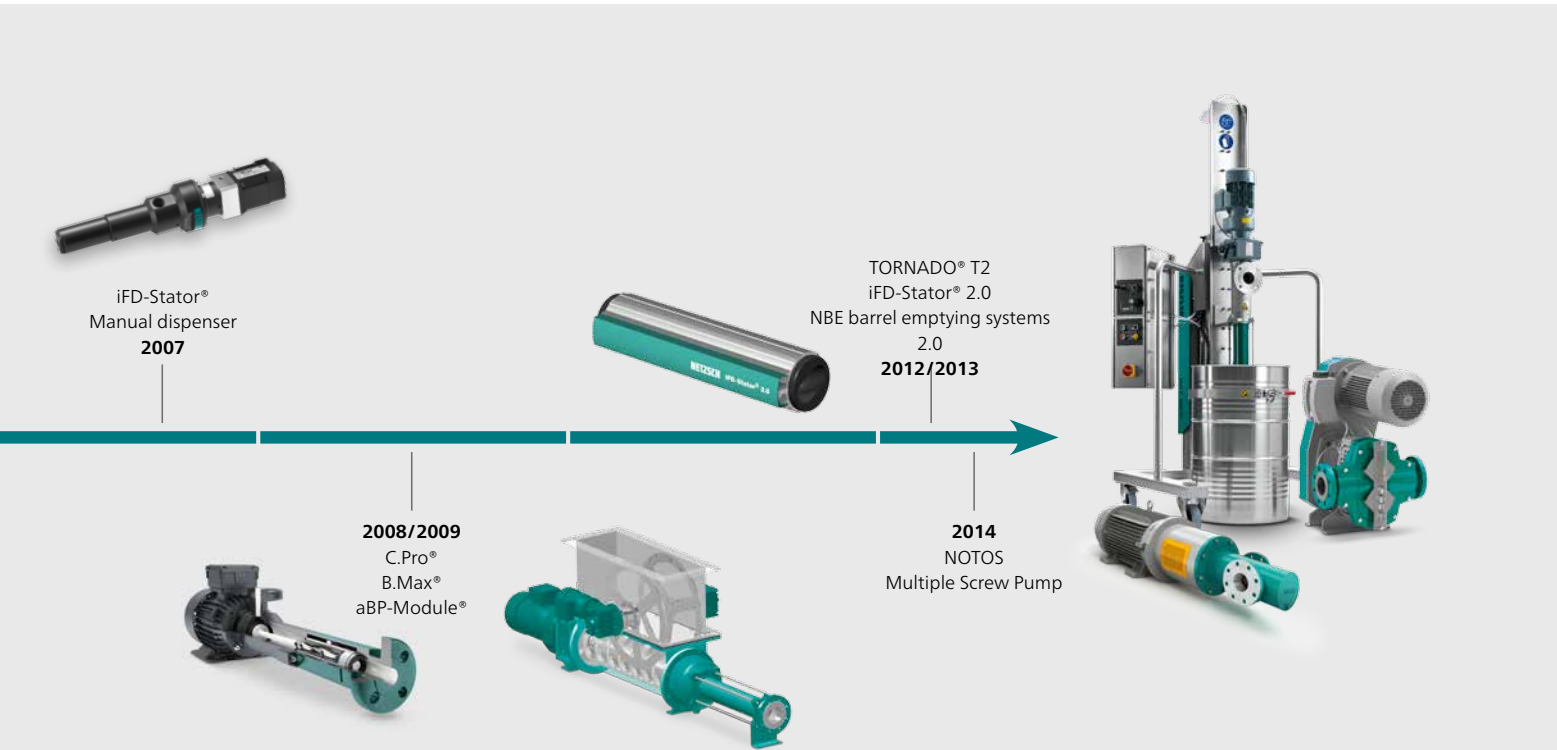

Organisation

NETZSCH has therefore developed an organisational structure that identifies the current needs of customers around the world by keeping an ear open to customers everywhere across a closely integrated distribution network. The Business Field Managers – experts for the industries they work with – are therefore also project managers who work with developers and designers on new products and to improve existing product series all the time. A team of developers and designers from all five continents meets up regularly, sorts through requests received from customers and decides on new products. In total, around 120 expert employees are working around the world to research and develop new products. They include design engineers and application specialists.

Successes

Decades of global market leadership for displacement pumps is the direct result of NETZSCH's innovative strength. Our leadership is reflected again and again in the awards the company wins around the world. For example, our NEMO® B.Max® biogas and TORNADO® rotary lobe pumps have won numerous

awards, as have components such as the CERATEC® ceramic rotor and the iFD-Stator®, which won an award for its low environmental impact and sustainability in development and production, during energy-saving operation and at end of life.

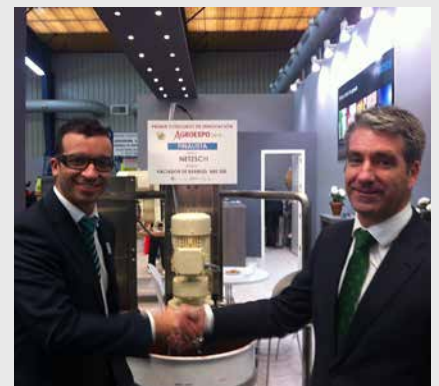

Business Fields – Products and Components

Faster and faster development cycles coupled with constantly increasing process requirements call for ambitious and uncompromising solutions in all industries. We understand and meet the requirements of our customers thanks to our global business segment structure employing experienced and competent specialists.

Further information

Business Field Environmental & Energy	Brochure NPS · 307
Business Field Chemical, Pulp & Paper	Brochure NPS · 306
Business Field Food & Pharmaceutical	Brochure NPS · 308
Business Field Oil & Gas	Brochure NPS · 500
Business Field Systems	Brochure NDB · 386

Product Range

For every application we offer you the optimum pump or the best system from our comprehensive product range. To find your competent contact partner, please see the contact details by industry on the opposite page.

NEMO® Progressing Cavity Pumps

- Standard pumps
- Hopper pumps
- Hygienic and aseptic pumps
- Immersible pumps
- Downhole pumps
- Multiphase pumps
- Highpressure pumps (injection pumps)
- Custom built pumps

NETZSCH Dosing and Barrel Emptying Systems

- Barrel emptying systems
- 1K dosing systems
- Dispenser

TORNADO® Rotary Lobe Pumps

- T.Econ, T.Envi®, T.Proc®, T.Sano®
- Mobile pumps
- Custom built pumps

NETZSCH Grinder

- M-Ovas® Cutting Plate Macerator
- Twin shaft macerator

NETZSCH Accessories

- Protection devices
- Flushing/pressurised flushing devices
- Control units
- Transport devices
- Tools and much more

NOTOS Multiple Screw Pumps

- 2 Screw Pump: 2 NS
- 3 Screw Pump: 3 NS
- 4 Screw Pump: 4 NS



Environmental & Energy

Agriculture, construction industry, drinking water purification, electroplating, renewable energies, ship chandlers, water and waste water treatment and similar



Chemical, Pulp & Paper

Biofuel, building material, ceramics and glass, chemical and biochemical, explosives, leather/tanneries, mining and smelting, paint and varnish, paper and pulp/cellulose, textile, wood processing and similar



Food & Pharmaceutical

Bakery products, beverages, breweries, dairies, fish and meat processing, fruit processing, pharmaceutical and cosmetic products, sugar and starch, wine and similar



Oil & Gas

Upstream

Onshore and offshore oil extraction

Mid-/downstream

Oil transfer, petrochemicals, refineries, re-injection and similar



Systems

Skids for hydropower plants for cooling and lubrication, Skids for adjustment of turbine blades

NEMO® Progressing Cavity Pumps

Features and design

NEMO® progressing cavity pumps are used in all sectors of industries to convey almost all types of media continuously, smoothly, with low pulsation and dosing in proportion to speed.

Broad range of applications

The pumps are primarily used with media that have the following features:

- Containing solids (max. solid size up to 150 mm) and free of solids
- Low to high viscosity (1 mPas – 3 million mPas)
- Thixotropic and dilatant
- Shear sensitive
- Abrasive
- Non-lubricating and lubricating
- Aggressive (pH 0 – 14)
- Adhesive
- Toxic

Range of accessories

A wide range of accessories is available to protect and monitor the pumps (see page 30).

Further information

NEMO® Progressing Cavity Pumps
Brochure NPS · 305

Large capacity and pressure range

- Flow rates from just a few ml/h up to 1000 m³/h
- Number of stages ranging from 1 to 8 for pressures from 6 to 48 bar (standard) or up to 240 bar (high pressure)

A range of different conveying elements

Four different rotor/stator geometries are available to ensure the design is optimally adapted to the specific task.

Wide range of materials

Our range of metallic materials extends from simple grey cast iron and chrome-nickel steel to highly acid-resistant materials such as Duplex, Hastelloy and titanium to suit different conveying tasks. Ceramics and plastics round off the list for aggressive and abrasive applications. Our elastomers range from highly abrasion-resistant natural rubber, to oil-, acid- and alkali-resistant elastomers and finally Aflas and Viton. For products in which elastomers cannot be used because of high temperatures or for reasons of durability, a large number of solid-based stators made from plastics or metallic materials is available.

Large variety of shaft seals

The range of mechanical shaft seals includes simple seals with or without quench, double-acting seals arranged back to back or in tandem, and cartridge seals. For specific applications, stuffing-box packing, lip seals and special seals are available. A pump with magnetic coupling is available for use with toxic media – to guarantee 100% that there are no leaks.

Additional features

- High suction capacity – up to 9 mH₂O mWC
- Direction of rotation and flow can be reversed
- Can be installed in any position
- Quiet, smooth running
- Temperatures from - 20°C to + 200°C

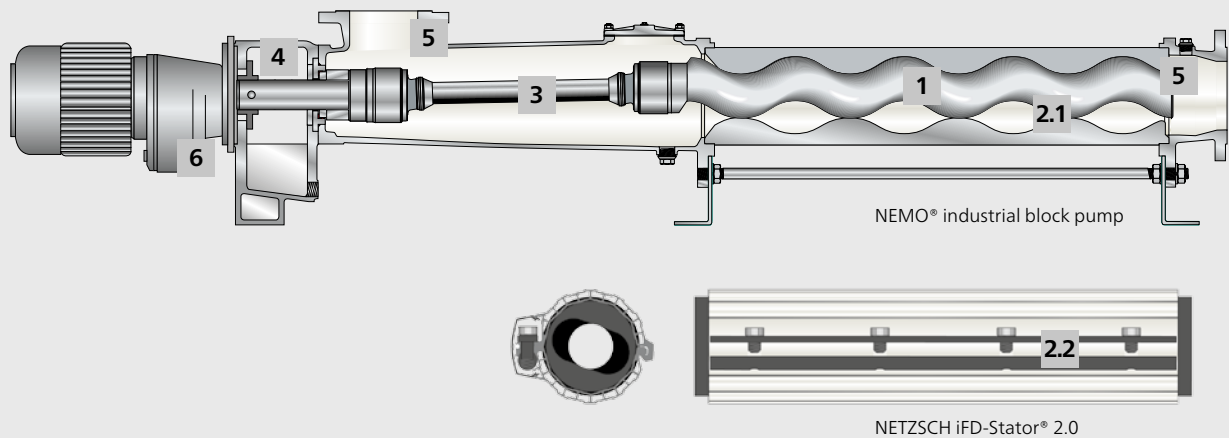

1 Rotor

From wear- and corrosion-resistant metal designs to the wear-free ceramic rotor NEMO CERATEC®.

2 Stator

We manufacture stators to the latest standards. Stators minimise the tolerance range thereby optimising the performance of the pump. Our unique, fully networked production and process data monitoring system, developed in-house, is backed up by consistent quality testing.

2.1 Stator with conventional technology

Vulcanised into the tubes with sealing collars on both sides in a wide variety of NEMOLAST® elastomers, plastics and metals. Stator inlet with funnel-shaped opening to improve product feed into the conveying chamber.

2.2 Stator with iFD Technology

The iFD Stator® consists of a two-part re-usable housing with a polygonal profile and the NEMOLAST® elastomer housed within. The advantages of this new technology includes a lower breakaway torque, higher efficiency, increased service life, simple and quick replacement, and straightforward disposal.

Further information provided in brochure NPS · 344

3 Drive train

The drive and connecting shaft with coupling rod and two universal joints provide the power transmission from the drive to the rotor.

4 Shaft sealing

Standard design with single-acting, wear-resistant, bidirectional mechanical seals. On request, single/

double-acting mechanical seals from a range of manufacturers, as well as cartridge and special seals and stuffing-box packing.

5 Suction and pressure housing

Hydrodynamic design with flange or thread connections in accordance with DIN and international standards. Grey cast iron, chromium-nickel-molybdenum steel, rubber-lined or Halar®-coated cast iron and special materials according to the respective specifications.

Halar® is a registered trademark of Solvay Solexis

6 Block design

As the drive is directly flanged onto the pump's lantern, the dimensions are compact, the overall weight is low, the shaft heights are constant irrespective of the design and size of the drive so the pump requires low maintenance, is easy to maintain and economical.

NEMOLAST® – elastomer quality developed, continuously tested and optimised at NETZSCH



Testing properties and quality

Elastomer research & development is in-house at NETZSCH. At its in-house laboratory and in close collaboration with selected materials suppliers established over many years, NETZSCH develops and tests elastomer blends and optimises them for the specific requirements of customers.

NETZSCH therefore offers each customer the optimum quality of elastomer for the media to be conveyed in terms of abrasion resistance, temperature range, dynamic load and chemical resistance – something other suppliers cannot offer. Only using original NETZSCH spare parts guarantees our pumps remain reliable.



Developing new blends



Manufacturing blends

60 years of experience in a wide range of industries and processes and 40 years of experience developing and manufacturing elastomers for NEMO® pumps led up to the development of complex bonded parts made of glass fibre, metal and elastomer for the housing inserts of our new generation of TORNADO® T2 rotary lobe pumps.

To meet the constantly growing demand for NETZSCH pumps and the associated demand for spare parts, NETZSCH invested in a new 4000 m² production hall in Waldkraiburg to produce elastomer parts using the latest production methods and the

latest product standards. Alongside five extruder sets to manufacture conventional tube stators, injection moulding machines and presses were also acquired to manufacture iFD-Stator®, lobes and housing inserts for rotary lobe pumps.



Extruder with conventional stator



Press with housing insert for TORNADO® T2



Injection moulding machine for iFD stators

TORNADO® Rotary Lobe Pumps

The NETZSCH TORNADO® positive displacement, self priming, valveless pumps offer high performance and are selected and configured for the individual requirements of each application. They are designed for intermittent or continuous operation and provide gentle pumping of the pumped media and ideally suited to transfer, process and dosing applications.

Their major benefits include minimal space requirements due to their compact design, high performance density and maximum operational reliability based on the unique spatial separation between pump chamber and gear compartment. TORNADO® rotary lobe pumps are especially easy to service and maintain; all parts that come into contact with the product are immediately accessible without having to dismantle pipelines or drive.

A broad application spectrum

NETZSCH TORNADO® pumps are suitable for a wide range of applications but are particularly good for liquids which:

- contain large solids, solids up to 70 mm in diameter can be pumped
- have a wide range of viscosities, from 1 mPas up to 1 million mPas
- are shear sensitive, i.e. thixotropic, dilatent, pseudoplastic, etc
- are fibrous and/or abrasive
- are lubricative or non lubricative

Characteristics

- Valve free construction
- Self priming
- Suitable for any kind of liquid including media containing gas, solids or fibrous matter
- Suitable for lubricating and non lubricating media
- Pumping media with high or low viscosity
- Handling shear sensitive fluids
- Operating at temperature up to 100°C
- Reversible operation
- Can be serviced without disconnecting pipework
- Tolerance of dry running

Large Range of Capacities and Pressures

- Capacities from 1 up to 1,000 m³/h
- Pressures up to 10 bar

Further information

The TORNADO® rotary lobe pump
Brochure NPS · 081

Functioning principle

The TORNADO® rotary lobe pump is a positive displacement pump. The pumping action is generated by the contra-rotation of two rotors within the pump chamber which are synchronised externally. The media enters the pump chamber through the inlet port and is carried around the chamber by the rotors to the outlet port where it is discharged.

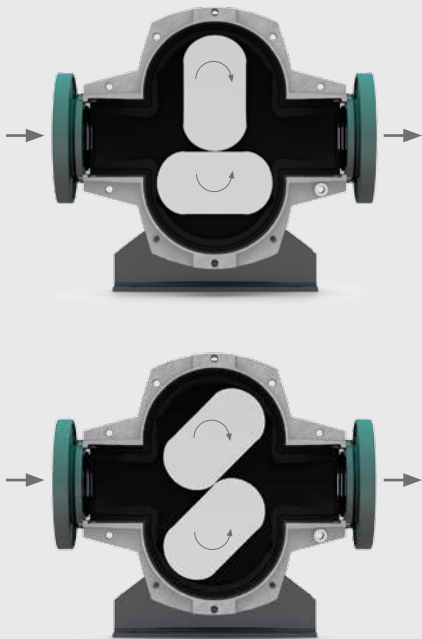

Pulsation-free
conveying

TORNADO® T2 – Revolutionary in design and customer benefit



Rapid assembly

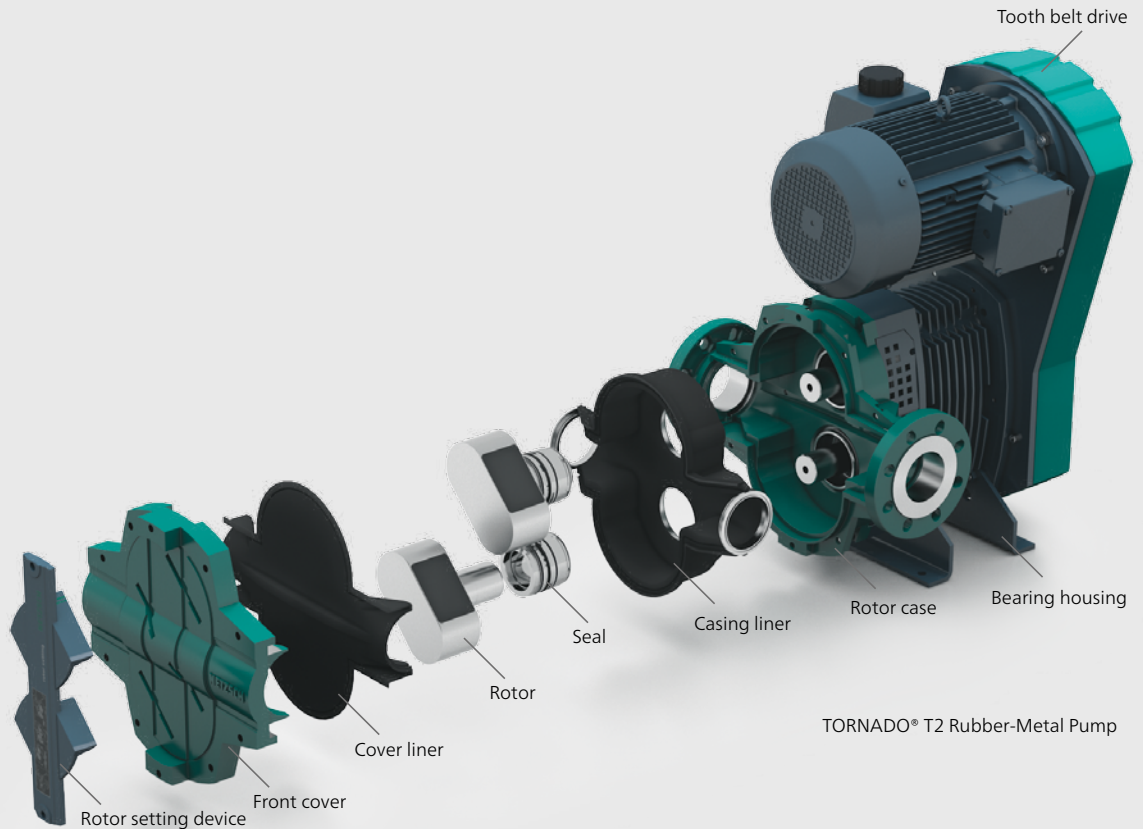

TORNADO® T2 Rubber-Metal Pump

Ease of service

“Full Service In Place” instead of “Maintenance In Place”

Servicing is easy, no special tool is required. Compared to traditional rotary lobe pumps, the TORNADO® T2 can be serviced in half the time. The rotary lobes can be replaced in next to no time, because the lobes are not screwed onto the shaft, but fixed with easily accessible taper lock ringsets. The simple geometry of the rotary lobes means that each lobe can be fitted and removed independently. You no longer need to make sure the

keys are properly seated, and there is no axial installation work needed on the rotary lobes. It is child's play to do this with the setting and installation gauge for positioning the rotary lobes, which is integrated into the front cover. The preset mechanical seals (cartridge design) are fitted onto the shaft, along with the rotary lobes. For the first time, different seal designs can be fitted without changing the mechanical seal housing.

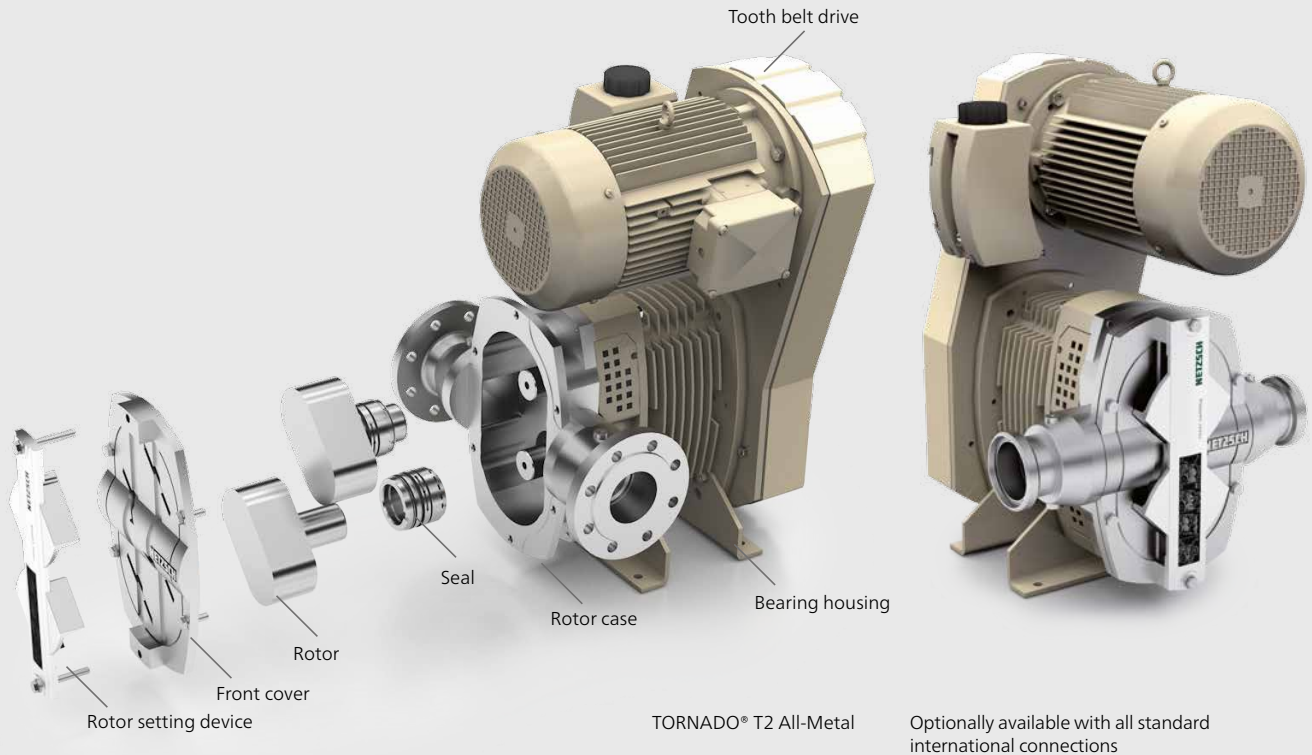

TORNADO® T2 All-Metal

Optionally available with all standard international connections

Process optimisation

Maximum reliability through design, material and choice of seal

The revolutionary NETZSCH PRS (Pulsation Reduction System) guarantees almost pulsation-free operation to benefit your process. Even when using bi-lobe rotors that handle solids more effectively and are easier to replace, we reduce pulsation to the level characteristic of multilobe conveying elements. The pump chamber design, mechanical seal design and position have no dead space, preventing product deposits and making cleaning easier, either manually or with the CIP process for fully metal pumps.

Operational safety

From GSS¹ to BSS²

The physical separation between pump chamber and bearing housing tried and tested in the TORNADO® T1 guarantees that each TORNADO® rotary lobe pump from NETZSCH is completely dependable.

¹ GSS = Gearbox Security System

² BSS = Bearing Security System

NOTOS Multiple Screw Pump

NOTOS Multiple Screw Pumps

Since 1979 NETZSCH has been manufacturing the Multiple Screw Pumps to serve a wide range of industries and applications.

The most advanced technology is utilized to produce these pumps. Reliability, durability and experience are some reasons why you should choose NETZSCH.

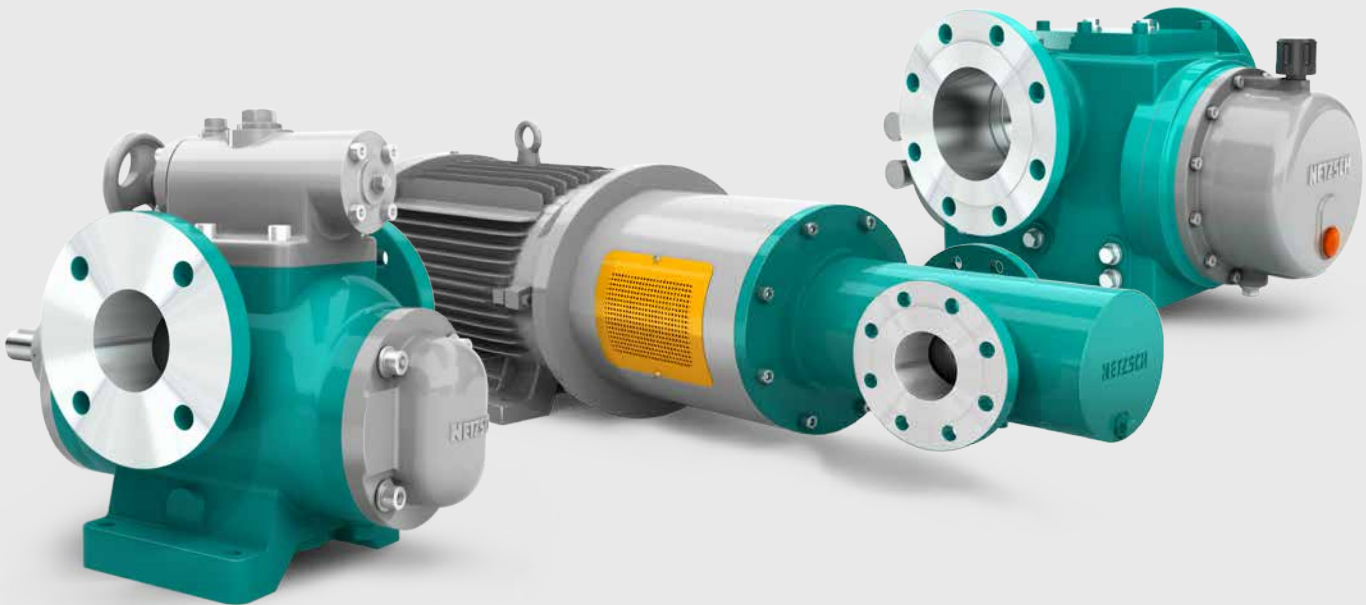

2 NS – Two Screw Pump

Suitable for light or heavy lubricating products, from low to high viscosity.

3 NS – Three Screw Pump

Suitable for clean products, high lubricity and medium from low to high viscosities.

4 NS – Four Screw Pump (Geared Twin)

Suitable for light or heavy lubricating products, low or high viscous medium including abrasive particles.

2 NS Series

NOTOS Two Screw Pumps have one driven screw and one concurrently rotating running screw, transferring torque due to the hydrodynamic film.

- Flow up to 320 m³/h (1410 gpm)
- Pressure up to 16 bar (230 psi)
- Temperature up to 300°C (570°F)
- Viscosity up to 10.000 cSt



1 Flanges

DIN, ANSI or SAE connections available.

2 Accessories

- Optional built-in relief valve.
- Optional heating.
- Optional API 682 mechanical seal

3 Arrangement

Foot mounted, pedestal mounted, semi-submersible or flange mounted.

4 Bearing Bushing

Internal bearing bushing helps to support radial loads.

Advantages

- High efficiency
- Hydraulically balanced
- Quiet operation
- Long service life
- Flow with low pulsation
- Complies with API 676 3rd Ed.



NOTOS Multiple Screw Pump

3 NS Series

NOTOS Three Screw Pumps have one driven screw and two concurrently rotating running screws, transferring torque due to the hydrodynamic film.

- Flow up to 100 m/h³ (440 gpm)
- Pressure up to 80 bar (1160 psi)
- Temperature up to 300°C (570°F)
- Viscosity up to 12.000 cSt



1 High Efficiency

Due to the unique design, the efficiency is extremely high.

2 Arrangements

Foot mounted, housing, light, flanged, vertical and semi-submersible.

3 Flanges

DIN, ANSI and SAE ports in-line or other options available.

4 Self Priming

Able to prime up to 8 m either vertically or horizontally mounted.

Advantages

- High efficiency
- Easy maintenance
- Lightweight and small footprint
- Low pulsation
- Complies with API 676 3rd Ed.

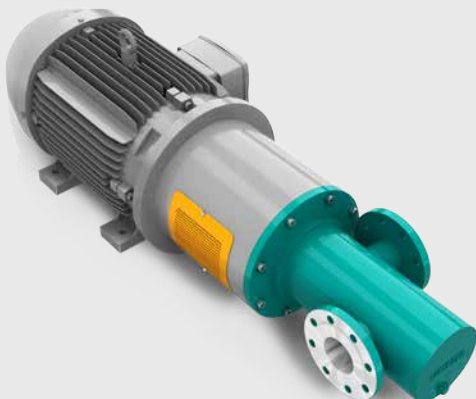

4 NS Series

NOTOS Four Screw Pumps (geared twin screw pumps) have two shafts with four screws rotating inside a cartridge with timing gears.

- Flow up to 620 m³/h (2700 gpm)
- Pressure up to 25 bar (360 psi)
- Temperature up to 300°C (570°F)
- Viscosity up to 50.000 cSt

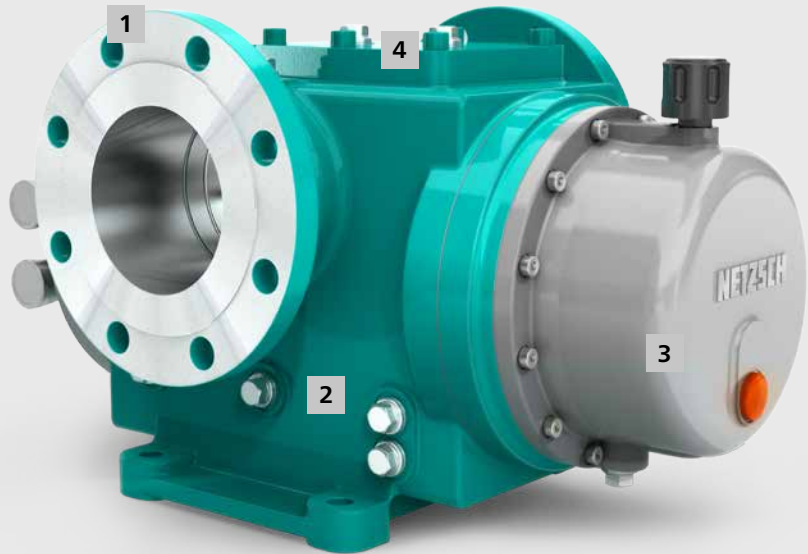

1 Flanges

DIN, ANSI or SAE available. Vertical flanges on request.

2 Arrangements

Vertical, horizontal, in-line or top discharge available.

3 Timing Gears

Helical timing gears transfer the torque, reducing vibration and noise.

4 Accessories

- Optional built-in relief valve.
- Optional heating. Optional
- API 682 mechanical seal.

Advantages

- High Efficiency
- No metal to metal contact
- Complies with API 676 3rd Ed.
- Small footprint
- Long operational lifetime



NOTOS Multiple Screw Pump

NOTOS Multiple Screw Pumps

The NOTOS Multiple Screw Pump (MSP) family has superior quality standards to meet the highest level requirements from our customers. Thanks to the unique design the Multiple Screw Pump covers a wide range of applications.

Range of applications

The pumps are designed to work with low to high lubricant fluids, low to high viscosity, shear sensitive or chemically aggressive media. The markets covered by the MSP are:

- Oil & Gas
- Marine industry
- Power
- General industry

Broad range of materials

Our range of metallic materials extends from simple grey cast iron and chrome-nickel steel to Duplex, superduplex or hastelloy steel.

- Different metal material options
- No rubber parts

Capacity and pressure ranges

Multiple Screw Pumps are known as pumps for low to high flow and low to high pressure:

- Flow rate from 1 m³/h up to 620 m³/h
- Pressure rate from 1 to 80 bar
- Viscosities from 0,1 to 50.000 cst
- Temperature from -25°C to 320°C

Characteristics

- Hydraulically balanced
- High suction power (up to 200 mbar abs.)
- Quiet operation
- Continuous flow with low pulsation
- Flow with minimal turbulences
- Mechanical seal available for vacuum.
- No foaming
- Low maintenance
- Low lifecycle cost
- Long service life
- Hydrodynamic bearings

2 NS Series

1 Flange Options

DIN, ANSI or SAE connections available.

2 Accessories

- Optional built-in relief valve.
- Optional heating.
- Optional API 682 mechanical seal.

3 Arrangements

Foot mounted, pedestal mounted, semi-submersible or flange mounted.

4 Bearing Bushing

Internal bearing bushings help to support radial loads.

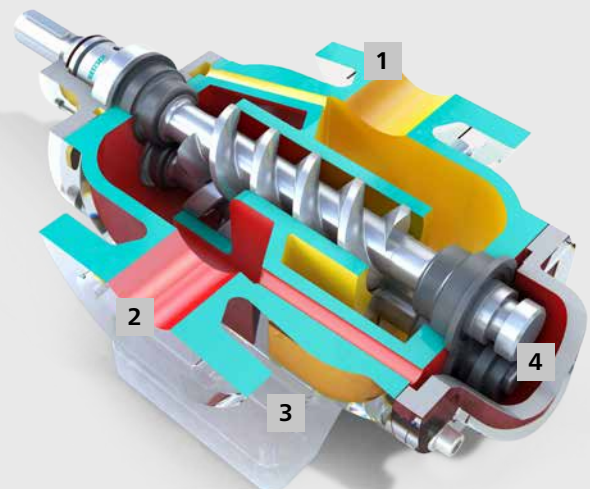

3 NS Series

1 High Efficiency

Due to the NETZSCH High Efficiency Unique Design (HEUD), the volumetric efficiency is extremely high.

2 Arrangements

Foot mounted, housing, light, flanged, vertical and semi-submersible.

3 Flanges

DIN, ANSI and SAE ports in-line or other options available.

4 Self Priming

Able to prime up to 8 m either vertically or horizontally mounted

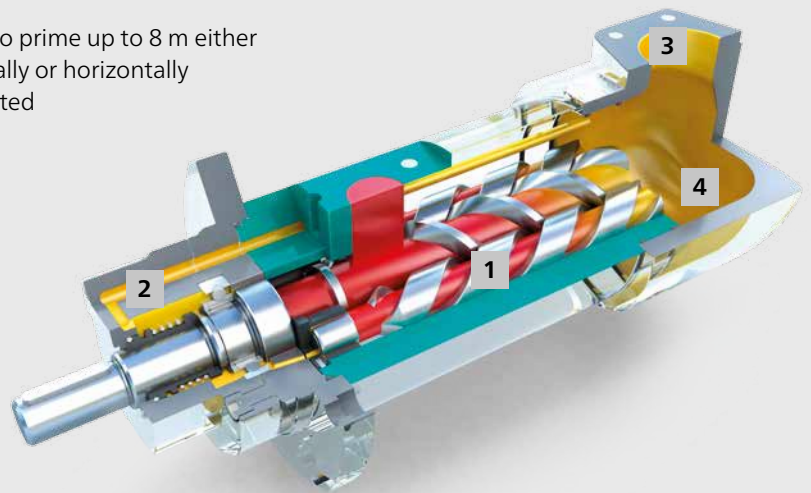

4 NS Series

1 Flanges

DIN, ANSI and SAE ports in-line or other options available.

2 Arrangements

Vertical, horizontal, in-line or top discharge available.

3 Timing Gears

Helical timing gears transfer the torque, reducing vibration and noise.

4 Accessories

- Optional built-in relief valve.
- Optional heating.
- Optional API 682 mechanical seal.

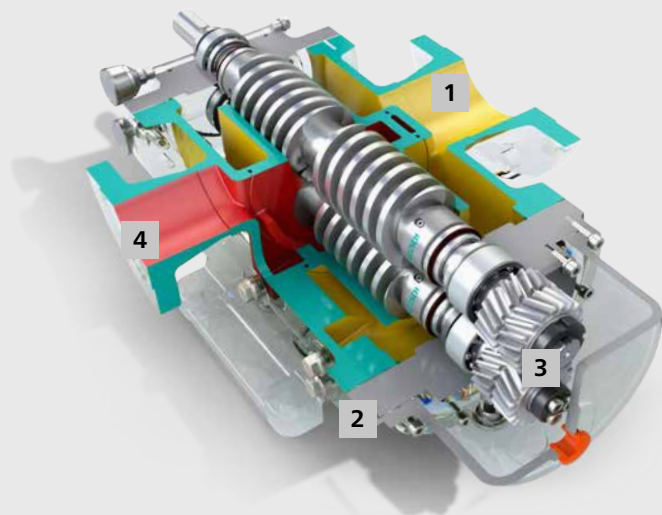

Further information

NOTOS Multiple Screw Pumps
Brochure NDB · 401

NETZSCH Dosing Technology and Barrel/Drum Emptying Units

It is good to have a choice

NETZSCH is a trend-setting problem solver thanks to consistent implementation and constant development of existing expertise. You benefit from our continuous optimisation of displacement pump technology. We also pay particular attention to further developing the dosing components in use by customers to meet the constantly growing statutory requirements and expectations in our markets.

Product Range of Dosing Technology

The product range of dosing technology contains

NETZSCH Barrel Emptying Units

To empty standard barrels from 20 l to 200 l. Flow rates from approx. 6 ml - 10 m³/h. Clean emptying, residue without inliner < 1 %.

NETZSCH Dosing Technology

Barrel emptying units, control unit, buffer vessel and dispenser are offered in combination for optimally tuned emptying and dosing.

NEMO® Dispenser

Flow rates from approx. 0.2 to 4.0 ml per revolution, dosing accuracy +/- 1 %.

NETZSCH Dosing control units

Start/stop control unit
1K control unit

NETZSCH Buffer Vessel

Buffer capacity approx. 1.0 l; delivers constant supply pressure to the dispenser, even with long pipework. This ensures high dosing accuracy and minimises the wear to rotor and stator. Barrels can be changed without stopping the system.

Further information

Dosing Technology
Brochure NPS · 330

Advantages

- Low shear pumping and dosing of high viscosity, highly abrasive and filled products.
- Product remaining in barrel after emptying < 1-2 % of the total volume
- Low system working pressures
- No pressure or flow hiatus in the system
- Barrel changes without interrupting the production process
- Valve-less dosing system ideal for filled products
- Speed proportional dosing, repeatable accuracy
- Volumetric dosing accuracy >99 %, independent of the viscosity
- Simple integration of the dispenser with robots
- Servo drives available for high loads
- Continuous, gentle, and pulsation free dosing
- With suck-back, no dripping or stringing by dosing
- Low life cycle costs
- Complete heating possible

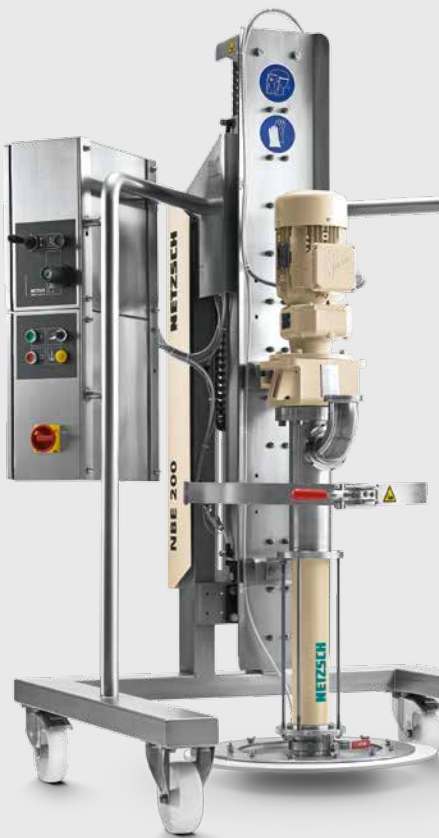

NETZSCH barrel emptying system NBE 200 with hygienic design



NETZSCH barrel emptying system NBE 20 with industrial design



NEMO® Dispenser

NETZSCH Grinders

M-Ovas® Cutting Plate Macerator

The M-Ovas® is used in all sectors of industry where impurities in the medium inhibit the reliability of the process. The solids in the medium are reliably macerated to prevent pipework and downstream machinery becoming blocked.

High flow rates

- Flow capacities up to 300 m³/h for waste water and sludge with up to 7 % dry solid content
- Two sizes available depending on throughput rate

Broad range of applications

The NETZSCH M-Ovas® is the preferred choice for media in the following industries:

- Biogas plants
- Spas and health resorts
- Sewage and waste water treatment plants
- Agriculture
- Leather production
- Organic bio-waste recycling
- Paper and pulp industry
- Slaughterhouses
- Animal carcass treatment
- Sugar factories

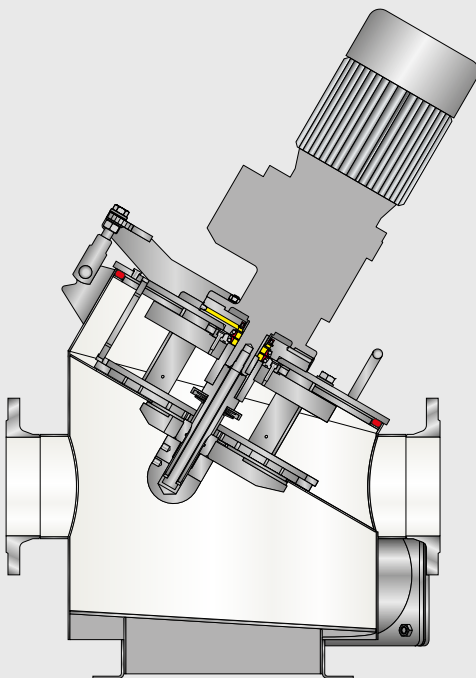

Advantages

- Compact design with high throughput rate
- Simple, easy dis-assembly of the cutting plate and knife unit
- Low energy requirement with high throughput rate
- Integrated separator vessel with separate cleaning and drainage aperture
- Effortless disposal of the sedimented materials through easy access
- The rigid cutting unit with minimised gap delivers greater cutting efficiency and avoids blockages, significantly reducing wear; optional with fixed cutting unit
- Shaft sealing using mechanical seal with lubrication
- Particularly maintenance friendly

Further information

Grinding Systems
Brochure NPS · 040

NETZSCH Twin Shaft Macerator

The NETZSCH twin shaft macerator is ideal for applications with particularly coarse and compact impurities in the waste water flow.

The twin shaft macerators are impressive with robust design, simple operation and high performance. They deliver optimum performance, even under the most extreme conditions. The twin shaft macerator ensures free flow, protecting the pumps and other plant equipment.

Depending on the application, five different models are available in various designs. The low drive power with particularly high flow rate enables cost-effective use.

High flow rates

Flow rates from 1 m³/h to 300 m³/h with a solid content of up to 10 %

Broad range of applications

The NETZSCH twin shaft macerator is particularly suitable for media in the following industries:

- waste water industry
- Industrial kitchens
- Canning factories
- Agriculture
- Slaughterhouses and recycling plants
- Sugar factories

Advantages

- Optimised price-performance ratio
- Very low operating costs due to optimum efficiency level
- High operational reliability thanks to simple maintenance due to the cartridge design cutter technology
- The very slow, variable speed of the shafts means that the NETZSCH twin shaft macerator can be self-cleaning
- Robust design, simple operation and high performance

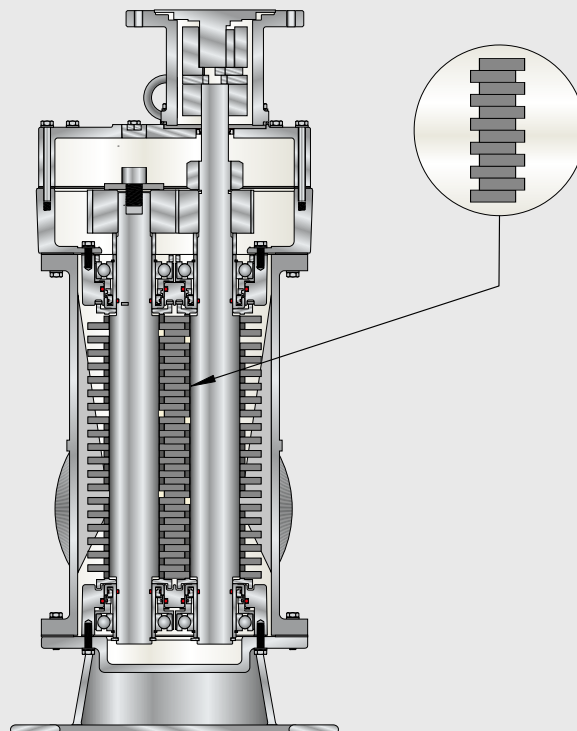

Accessories to increase the operational safety of both pump and plant to prevent downtimes

Process monitoring

Dry running protectors safeguard elastomer parts of the pump against thermal damage and protect the pump.

- Dry running protection (STP2A, STP2D)
- Flow sensors for solid stators
- Speed monitoring device

Overpressure and underpressure protectors safeguard the pump and protect downstream machinery and valves against overpressure and underpressure.

- Diaphragm Pressure Gauge
- Pressure control device DTSL 3
- Multi-function pressure instrument
- By-pass line

Seal Support Systems

Additional flushing, quench or pressurised flushing systems that flush or close the seals with clean conveyed medium are often required to ensure shaft seals function correctly and reliably.

- Quench pot
- Permanent lubricator
- Pressurised flush for double mechanical seals

Tools and additional equipment

A large number of useful equipment is available to correctly maintain and smoothly operate your pumps.

- Gear joint filling unit
- Ring dosing nozzle
- Chemical anchor
- Stator removal tool

Protection Units and Trolleys

In all areas of production within the food, pharmaceutical and cosmetic industries, a range of optional parts are available to ensure uncompromising hygiene and to enable mobile use.

- Covers for drives
- Transport devices
- Machine feet - flexible, rigid

Further information

NETZSCH Customer Service
Brochure NPS · 400

NETZSCH Service

The benefit to you

Advice, service and quality are our strengths. Strict quality standards, test procedures and certification in accordance with DIN EN ISO 9001 guarantee that you receive the very highest quality without exception. To maintain the performance and quality of your pump, we continue to provide support after delivery in all aspects of your pump to ensure it operates reliably in your system. We have experience over 60 years with more than 500,000 installed pumps behind us.

Spare Parts and Service

In your area welltrained service partners are available for quick and economic service of the pumps at your premises. You will find your personal service partner in our homepage at www.netzsch.com | Pumps & Systems | Consulting & Service.



The NETZSCH Group is a mid-sized, family-owned German company engaging in the manufacture of machinery and instrumentation with worldwide production, sales, and service branches.

The three Business Units – Analyzing & Testing, Grinding & Dispersing and Pumps & Systems – provide tailored solutions for highest-level needs. Over 3,000 employees at 163 sales and production centers in 28 countries across the globe guarantee that expert service is never far from our customers.

The NETZSCH Business Unit Pumps & Systems offers with NEMO® progressing cavity pumps, TORNADO® rotary lobe pumps, screw pumps, macerators/grinders, dosing technology and equipment custom built and challenging solutions for different applications on a global basis.

NETZSCH Pumpen & Systeme GmbH
Geretsrieder Straße 1
84478 Waldkraiburg
Germany
Tel.: +49 8638 63-0
Fax: +49 8638 67 981
info.nps@netzsch.com
www.netzsch.com

