

## NEMO® C.Pro®

Less is More

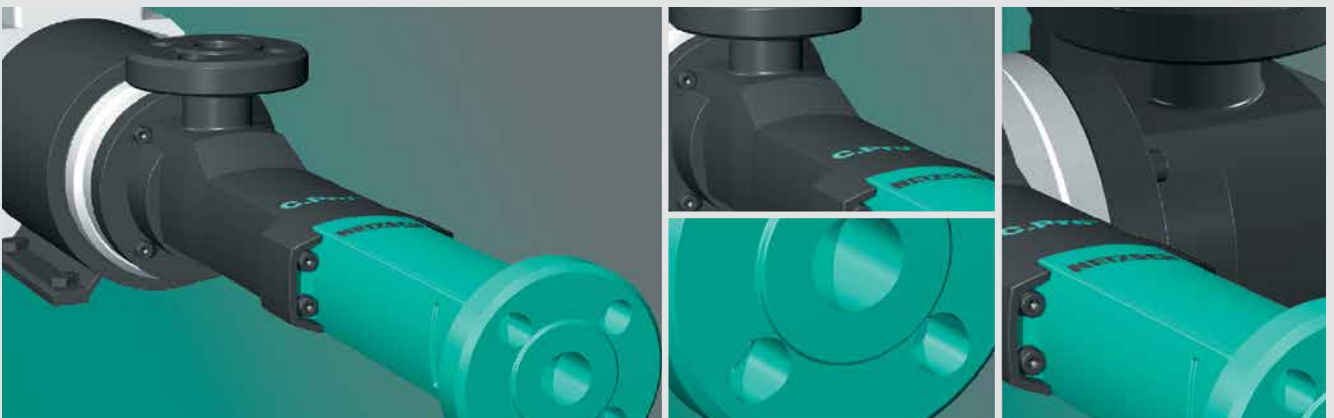

# NEMO® C.Pro® – Economic, Environmentally and Service Friendly

## Characteristics and Construction

**NEMO® C.Pro® is an innovative pump series for conveying and metering small capacities. It has been developed from a continuing evolution of the well known NEMO® Mini and NEMO® M.Champ® progressing cavity pumps.**

An important aim of this development has been the significant reduction of parts. With now only 6 parts the NEMO® C.Pro® is unmatched in economy and service friendliness. The rotor and stator can be changed in just a couple of minutes with just an allen key. Through the use of highly resistant PU (Baydur® GS) for the housing and PVDF or stainless steel for the rotating unit the installation possibilities for the NEMO® C.Pro® are wider ranging.

### Wide Range of Applications

The NEMO® C.Pro® has been designed especially for the use in water processing, waste water treatment and in the chemical industry for continuous and nearly pulsation free metering of process additives. The NEMO® C.Pro® is specifically designed for products with the following characteristics:

- Products with or without solid particles
- Low to medium viscosity (up to 20,000 mPas)
- Thixotropic and dilatant
- Shear-sensitive
- Abrasive
- Lubricative and none lubricative
- Aggressive (pH 0 - 14)
- Adhesive

### Large Range of Capacities and Pressures

- Capacity from 0,5 to 1,500 l/h
- Pressures up to 20 bar

### Advantages

- Continuous and low pulsation conveyance
- Speed proportional metering
- Reversible direction of rotation and conveyance
- High suction and pressure capacity
- One part rotating unit with a stainless steel or PVDF rotor
- Mechanical seal in product flow
- Maintenance free and service friendly
- Compact and economic
- Temperature 0°C to 40°C
- High metering precision with deviation +/-1%

### Typical Media

- Natural and artificial polymers
- Anionic and cationic polyelectrolyte
- Water and waste water samples
- Suspensions
- Dispersions
- Alcohols
- Oils
- Further applications, also mixed products on request

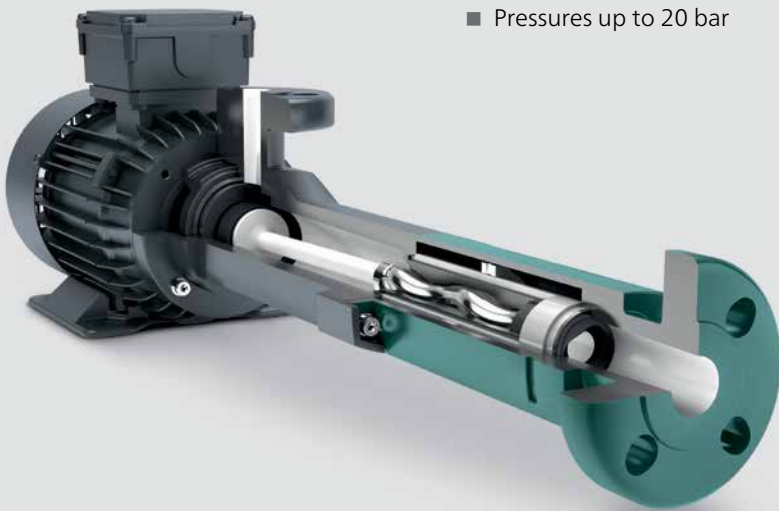

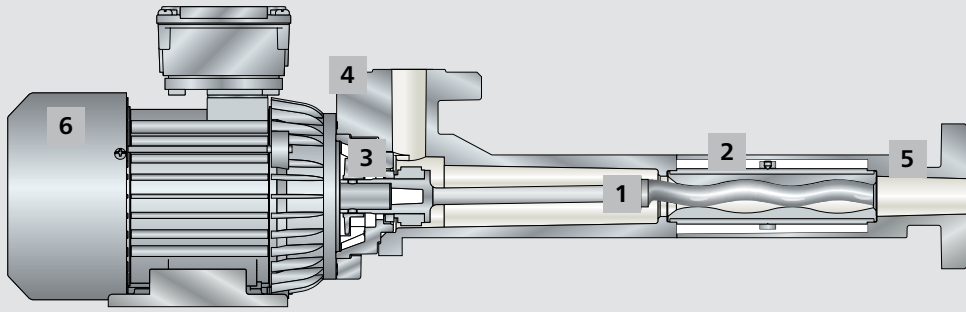

NEMO® C.Pro® Plastic Dosing Pump

## 1 Rotating Unit

With the new single part, joint and maintenance free rotating unit, many parts have been removed. This makes the pump highly economic and service friendly. As standard the pump is supplied with a stainless steel rotor or PVDF as an alternative. For applications whereby abrasive or non lubricating media have to be pumped the NEMO® C.Pro® is available with a chrome plated, CrNiMo 17-12-2 stainless steel, rotor.

## 2 Stator

The NEMO® C.Pro® is fitted with a stator in a variety of NEMOLAST® elastomers. We manufacture stators to the latest standards. The stators are manufactured to the closest of tolerances, thereby optimising the performance of the pump. Our unique, fully networked production and process data monitoring system, developed in-house, is backed up by consistent quality testing.

## 3 Mechanical Seal and Housing

The crevice free mechanical seal is positioned in the product flow, ensuring permanent flushing by the medium and preventing the sedimentation of solid materials. As standard a fully encapsulated single-acting mechanical seal to DIN 24960 is installed. The seal has faces in solid SIC and is suitable for use in both directions of rotation.

## 4 Suction Housing and

## 5 Stator and Discharge Housing

The housing is made out of abrasion proof and highly resistant polyurethane. The universal flange DN20 PN16 to DIN and 3/4" to ANSI B16,5 150 LBS makes installation and removal from the plant easy.

## 6 Drive

As standard delivered with a 6 pole three phase motor and frequency converter for control panel mounting. As an option also available with 6 pole three phase motor complete with cooling fan and integrated frequency converter for manual speed control via integrated potentiometer or control by a 4-20 mA/2-10 V signal. The drive is complete with an illuminated on-off switch, a direction reversing switch and a 1.5 m power cable with CE or US plug.

The NETZSCH Group is a mid-sized, family-owned German company engaging in the manufacture of machinery and instrumentation with worldwide production, sales, and service branches.

The three Business Units – Analyzing & Testing, Grinding & Dispersing and Pumps & Systems – provide tailored solutions for highest-level needs. Over 2,700 employees at 140 sales and production centers in 27 countries across the globe guarantee that expert service is never far from our customers.

The NETZSCH Business Unit Pumps & Systems offers with NEMO® progressing cavity pumps, TORNADO® rotary lobe pumps, screw pumps, macerators/grinders, dosing systems and equipment custom built and challenging solutions for different applications on a global basis.

NETZSCH Pumpen & Systeme GmbH  
Geretsrieder Straße 1  
84478 Waldkraiburg  
Germany  
Tel.: +49 8638 63-0  
Fax: +49 8638 67981  
info.nps@netzsch.com

[www.netzsch.com](http://www.netzsch.com)