

Reducing costs and increasing efficiency in fish meal factories

Targeted process optimisation with NETZSCH pumps

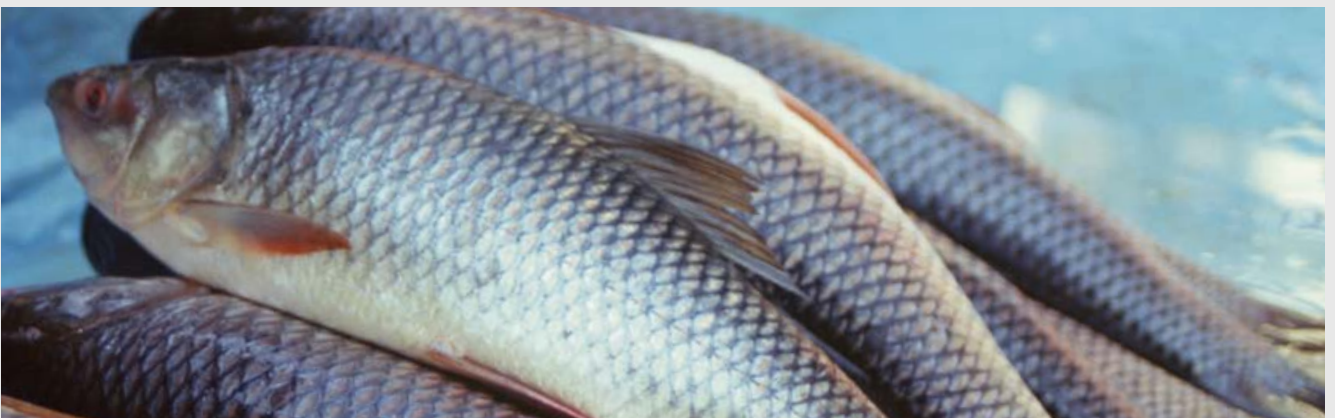

Optimisation of existing plants – redesign, from landing the fish to processing the water

With NETZSCH pumps you reduce your costs and maximize your returns

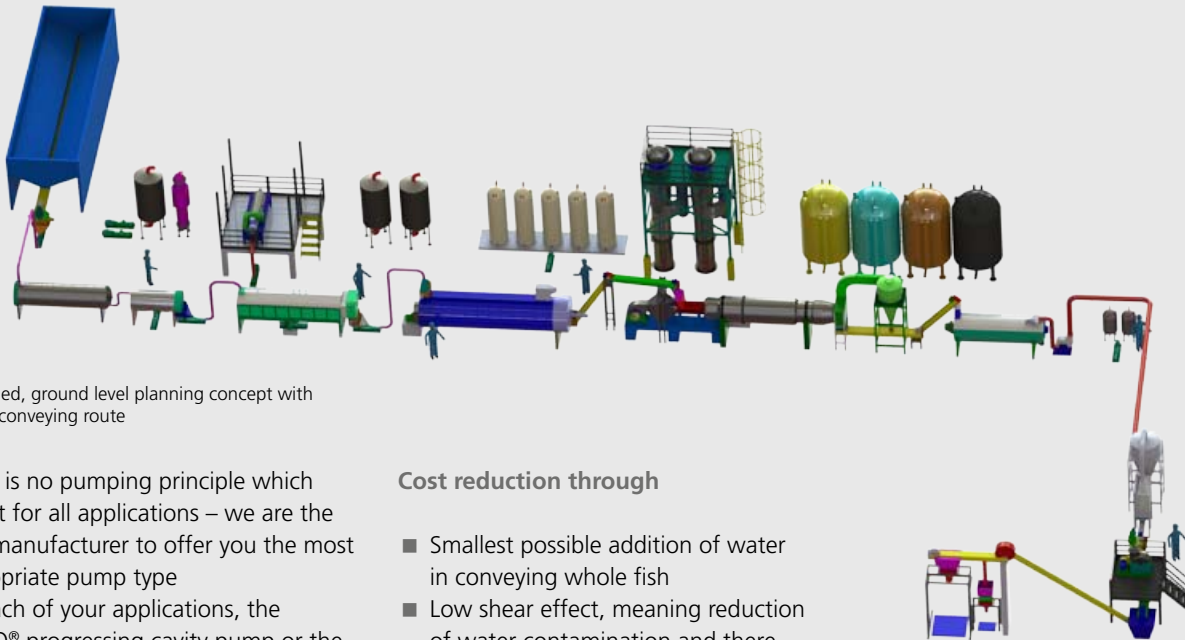

Simplified, ground level planning concept with closed conveying route

There is no pumping principle which is best for all applications – we are the only manufacturer to offer you the most appropriate pump type for each of your applications, the NEMO® progressing cavity pump or the TORNADO® rotary lobe pump. As your partner in developing and implementing comprehensive solutions, we give you competent and knowledgeable advice. Take advantage of our 50 years' experience and our worldwide market and technology leadership.

Cost reduction through

- Smallest possible addition of water in conveying whole fish
- Low shear effect, meaning reduction of water contamination and therefore significantly lower blood water processing requirement
- Closed conveying route to protect the plant and equipment against corrosion
- Considerably simplified plants which are constructed entirely at ground level

Maximization of returns through

- Smooth conveyance of the fish meaning fewer rejects
- Maximum yield of components: oil, protein and fish meal



Conventional plant over several levels

NETZSCH has been a manufacturer of positive displacement pumps for decades and at the same time a solutions provider for a wide range of industries.

Due to its operating principle and the smooth conveyance of both media containing solids and shear-sensitive media, NETZSCH NEMO® progressing cavity pumps and NETZSCH TORNADO® rotary lobe pumps are ideally suited for use in fish meal factories:

- For landing fish
- For processing fish
- For waste water treatment

Using them means you can both maximize returns and reduce costs.



Landing fish: considerable reduction of rejects and lower pollution with blood water when pumping with progressing cavity pumps (right) instead of centrifugal ones (left).

NETZSCH offers the full range of pump equipment for the whole plant from one single source, so that you can optimise the processes and costs of your fish processing plants. Focused on ecological and business factors. Experienced engineers and technicians offer you individual, solution-orientated approaches for your business.

We would be happy to provide you with a personal consultation.



Main applications for the use of NETZSCH pumps

Landing fish

When unloading fish from fishing boats, the use of NEMO® progressing cavity pumps means fish can be drawn in whole and conveyed with only a small amount of seawater being added. Centrifugal pumps, which, in comparison to the NEMO® progressing cavity pump, seriously break up the fish and need large quantities of water for conveyance, cause significant pollution of the sea's ecosystem. NEMO® progressing cavity pumps enable very smooth conveyance of fish and marine animals up to 30 centimetres long. The main advantages of using them are the low investment costs and the small amount of space required in comparison to vacuum systems.

Fish processing

In this "classic" area of application NEMO PUMPS® show their special strength. Here it is essential to convey the bulk of fish as accurately and as consistently as possible at every stage of production, without mixing and thus hampering phase separation.

- 1.1 NEMO® pump (approx. 50 m³/h)
Accurately measures and feeds whole fish from the fish hopper to the fish cooker
- 1.2 TORNADO® pump (approx. 5.0 m³/h)
conveys blood water, small solids, seawater and oil from fish hoppers to the blood water cooker
- 1.3 TORNADO® pump (5.0 m³/h)
conveys coagulated blood water from the storage tank to the 3-phase decanter
- 1.4 TORNADO® pump (approx. 5.0 m³/h)
ensures the circulation of coagulated blood water in the storage tank
- 1.5 NEMO® pump (approx. 40 m³/h)
conveys cooked and strained fish to the press
- 1.6 NEMO® pump (approx. 35.0 m³/h)
conveys press water from the collector tank under the strainer and the press to the buffer tank
- 1.7 NEMO® pump (approx. 35.0 m³/h)
conveys press water from the buffer tank to the drier and 3-phase decanter
- 1.8 NEMO® pump (approx. 3.0 m³/h)
conveys fish oil from the 3-phase decanter to the fish oil collector tank
- 1.9 NEMO® pump (approx. 35 m³/h)
conveys stick water from the 3-phase decanter to the collector tank in front of the evaporator
- 1.10 TORNADO® pump (approx. 8.0 m³/h)
conveys stick water concentrate to the collector tank
- 1.11 NEMO® pump (approx. 8.0 m³/h)
doses stick water concentrate for filter press cake
- 1.12 NEMO® dosing pump/TORNADO® pump (approx. 0.5 m³/h)
doses antioxidants for fish meal

Waste water processing

Using a small amount of seawater, the catch is pumped off the fishing boats into the factory. With NEMO® progressing cavity pumps, the fish parts and fish oil obtained in this process can be used cost-effectively.

- 2.1 NEMO® pump
pumps the seawater separated from the fish to the solids strainer
- 2.2 NEMO® pump (approx. 12 m³/h)
conveys the strained scales, fish parts and oil to production
- 2.3 NEMO® pump (340 m³/h)
conveys solid-free pump water comprising seawater with fish oil and very fine fish solids (< 1 mm) to the 1st flotation plant
- 2.4 NEMO® pump (approx. 20 m³/h)
conveys flotote (seawater/oil) to an intermediate tank
- 2.5 NEMO® pump (approx. 10 m³/h)
conveys the mixture of fish oil, solids and seawater from the intermediate tank to the hot coagulator and 3-phase decanter for them to be separated. The oil is pumped on to crude oil processing by a NEMO® pump (item 2.6).
- 2.6 NEMO® pump/TORNADO® pump (approx. 2.5-4.0 m³/h)
conveys crude oil from the 3-phase decanter to the crude oil collector tank
- 2.7 TORNADO® pump (approx. 340 m³/h)
conveys pump water from flotation cell 1 through a chemical mixer to flotation cell 2
- 2.8 NEMO® dosing pump/TORNADO® pump (approx. 0.5 m³/h)
doses flocculants
- 2.9 NEMO® dosing pump/TORNADO® pump (approx. 0.5 m³/h)
doses flocculant setting agents
- 2.10 NEMO® pump (approx. 20 m³/h)
conveys flotote from the flotation cell to the 2-phase decanter
- 2.11 NEMO® dosing pump/TORNADO® pump (approx. 0.5 m³/h)
conveys solution to PH neutralization
- 2.12 NEMO® pump (approx. 2.5 m³/h)
conveys fish solids from the decanter to the fish press cake
- 2.13 NEMO® pump (approx. 1.5 m³/h)
conveys fish solids from the 3-phase decanter to the fish press cake

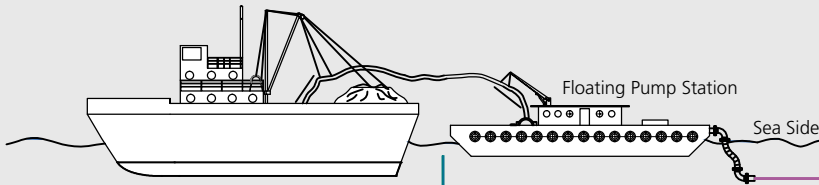

Further areas of application

Producing tinned food

- Pumping of waste (heads, tail fins, offal, etc.) to the collector tank
- Water-oil mixture pumping during fish canning

Disposal of fish scraps and processing fish scraps into fish meal

NEMO PUMPS® with hopper housings and conveyor screws are particularly useful here. The fish scraps are conveyed from the filleting tables by vacuum extraction or a water circulation system to the NEMO® pump, which then pumps the fish scraps out to the disposal point.

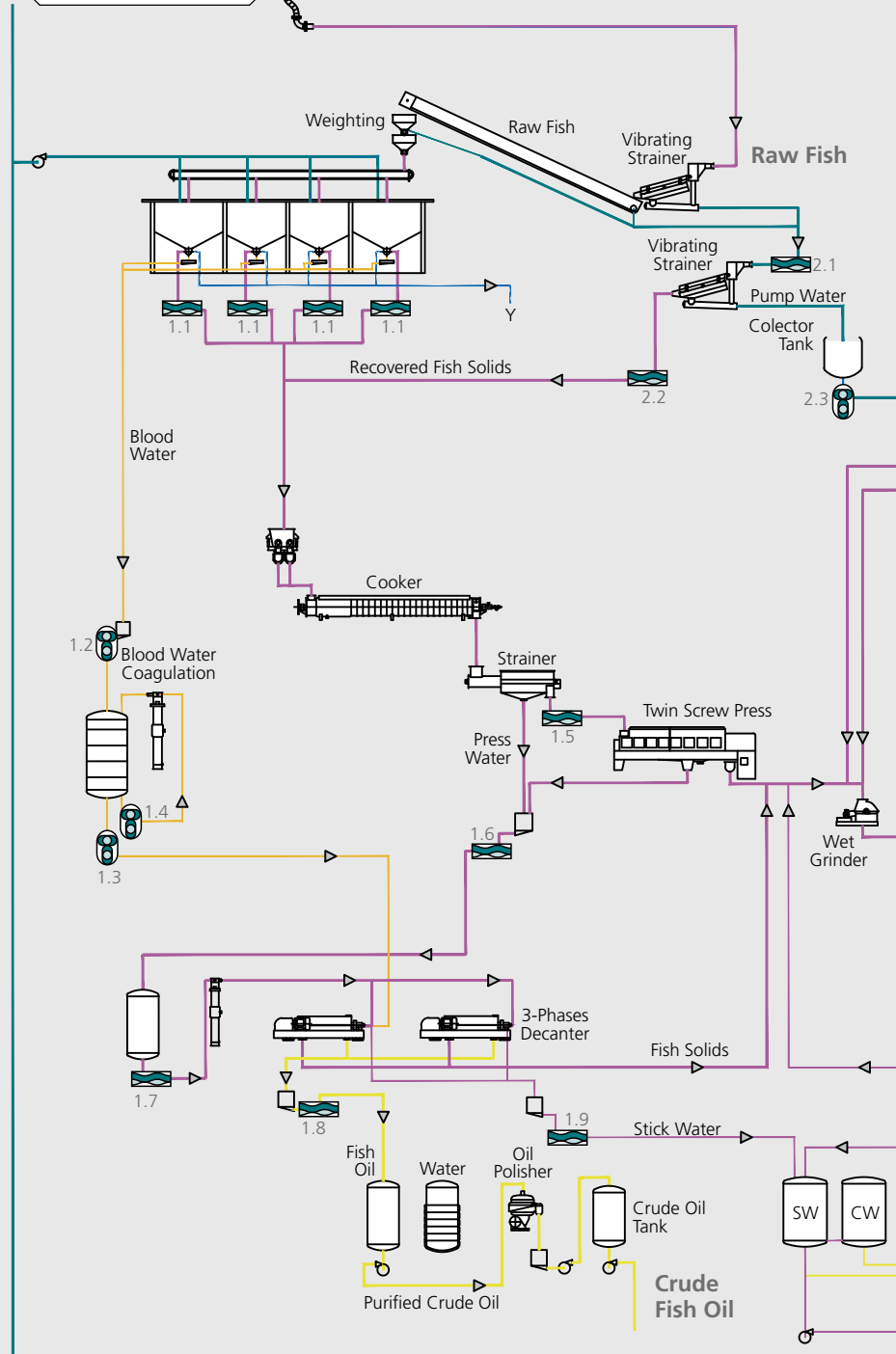

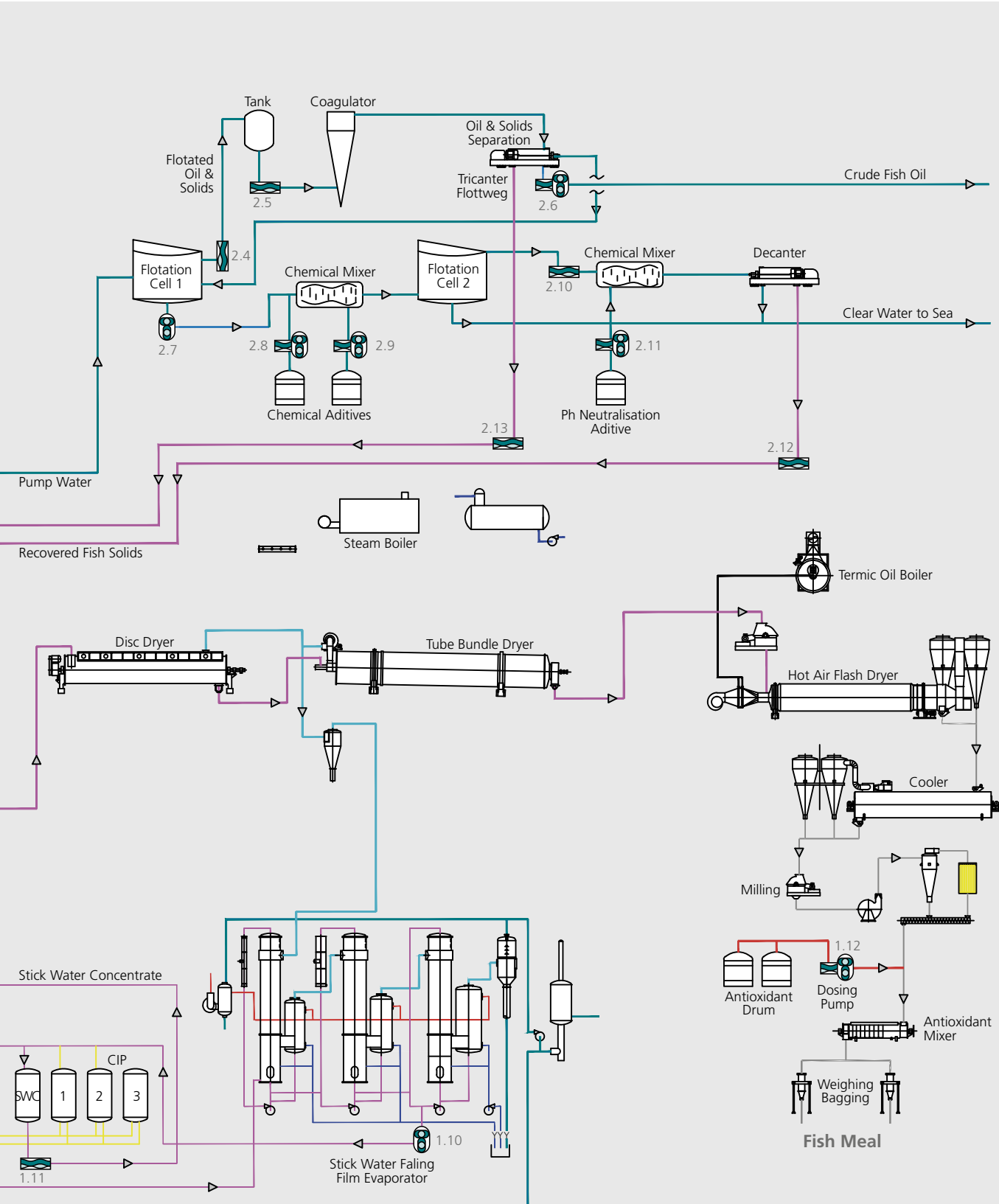

Progressing cavity pumps

The helical eccentric screw/rotor, which has a very long pitch and large thread depth, turns in an oscillating rotary motion within the fixed stator. This has an internal thread with the same geometrical proportions as the rotor, but with double the number of turns offset by 180° and double the pitch. As a result of this geometrical relationship, conveying cavities are formed between the rotor and the stator, in which the medium is transported in a smooth and continuous way from the inlet to the discharge side when the rotor rotates within the stator.

- Continuous, low-pulsation conveyance irrespective of pressure and viscosity
- High suction and pressure capacity
- Low investment and operating costs
- High operational reliability
- Various installation options

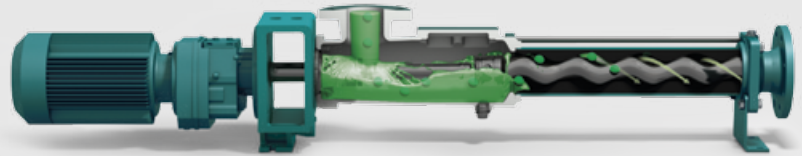

NEMO® progressing cavity pumps

Rotary lobe pumps

In a rotary lobe pump, the conveyed medium is drawn in by the vacuum produced by the rotation of the pair of lobes on the inlet side. The conveyed medium is then moved on by the lobes and goes past the pump wall into the discharge area. Depending on the type of lobes, with one drive revolution two to six cavities are displaced.

- Maximum operational reliability through physical separation of the pump and gear chambers (NETZSCH GSS technology)
- Maintenance in place
- Compact design means small space requirement
- Can be installed anywhere
- Great suction capacity of up to 8 mWS
- Highly resistant to dry running
- Direction of rotation and flow can be reversed
- Low life cycle costs
- Quiet, low-noise level when running

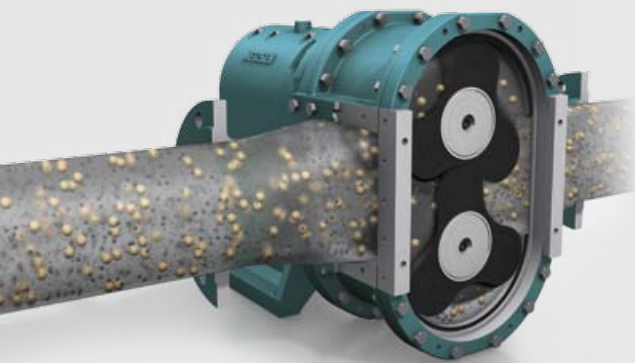

TORNADO® rotary lobe pump

NEMO® progressing cavity pumps and TORNADO® rotary lobe pumps

NETZSCH rotary lobe pumps and progressing cavity pumps, used individually or in combination, ensure you always have the right solution for your process.

NEMO® BY progressing cavity pump

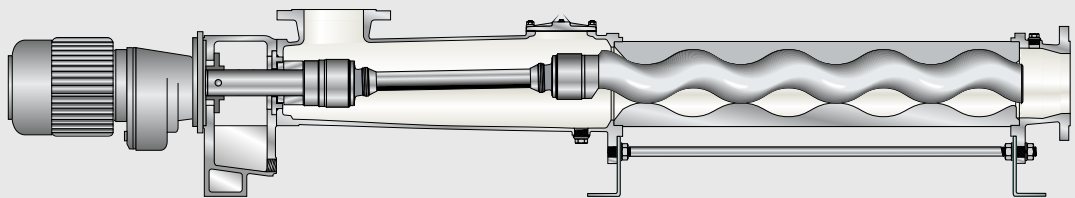

Compact design with directly flanged drive. It's low investment, operating and maintenance costs really make it stand out. Four rotor/stator geometries for optimum performance with every kind of application.

Large capacity and pressure range

- Capacities from just a few ml/h up to 400 m³/h
- Pressures up to 48 bar

Media features

- High dry matter content
- Highly abrasive
- Low to high viscosity
- Lubricating and non-lubricating
- Corrosive (pH 0–14)
- Heated and unheated
- Dilatant, thixotropic or shear thinning
- Toxic

Features

- Great suction capacity of up to 9 m water column
- Direction of rotation and therefore of conveyance reversible
- Can be installed anywhere
- Quiet, low-noise level when running
- Temperatures from -20°C to +200°C

Options

- With protective sleeve
- With inspection opening



TORNADO® rotary lobe pumps

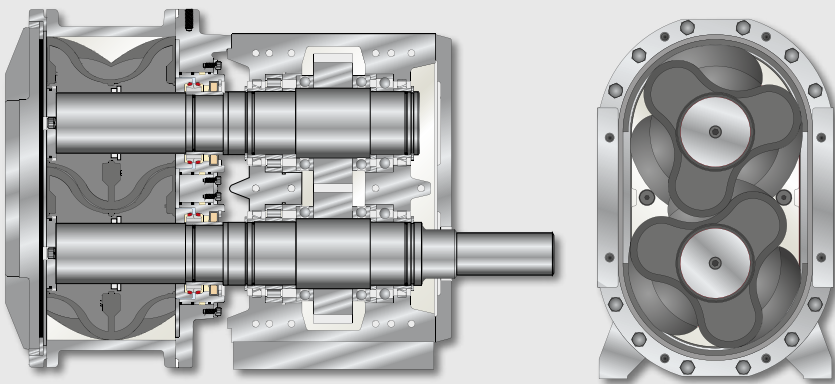

NETZSCH TORNADO® self-priming, valveless positive displacement pumps are high-performance and are tailored to individual requirements. They are used for continuous and smooth conveyance of almost all media, along with their dosing in proportion to speed.

Their great advantages are small space requirements due to their compact design, high performance and maximum operational reliability due to the unique physical separation between the pump and gear chambers. TORNADO® rotary lobe pumps are particularly service and maintenance friendly thanks to NETZSCH GSS technology; all parts

that come into contact with media are immediately accessible without dismantling any pipework or the drive.

Large capacity and pressure range

- Capacity up to 1,000 m³/h
- Pressures up to 6 bar



The NETZSCH Group is an internationally operating, owner-managed technology company headquartered in Germany.

The three Business Units – Analysing & Testing, Grinding & Dispersing and Pumps & Systems – provide tailored solutions for highest-level needs. Over 2,500 employees at 130 sales and production centers in 23 countries across the globe guarantee that expert service is never far from our customers.

The NETZSCH Business Unit Pumps & Systems offers NEMO® progressing cavity pumps, TORNADO® rotary lobe pumps, screw pumps, macerators/grinders, dosing systems and equipment custom built and challenging solutions for different applications on a global base.

NETZSCH Mohnopumpen GmbH
Geretsrieder Straße 1
84478 Waldkraiburg
Germany
Tel.: +49 8638 63-0
Fax: +49 8638 67981
info.nmp@netzsch.com

www.netzsch.com