

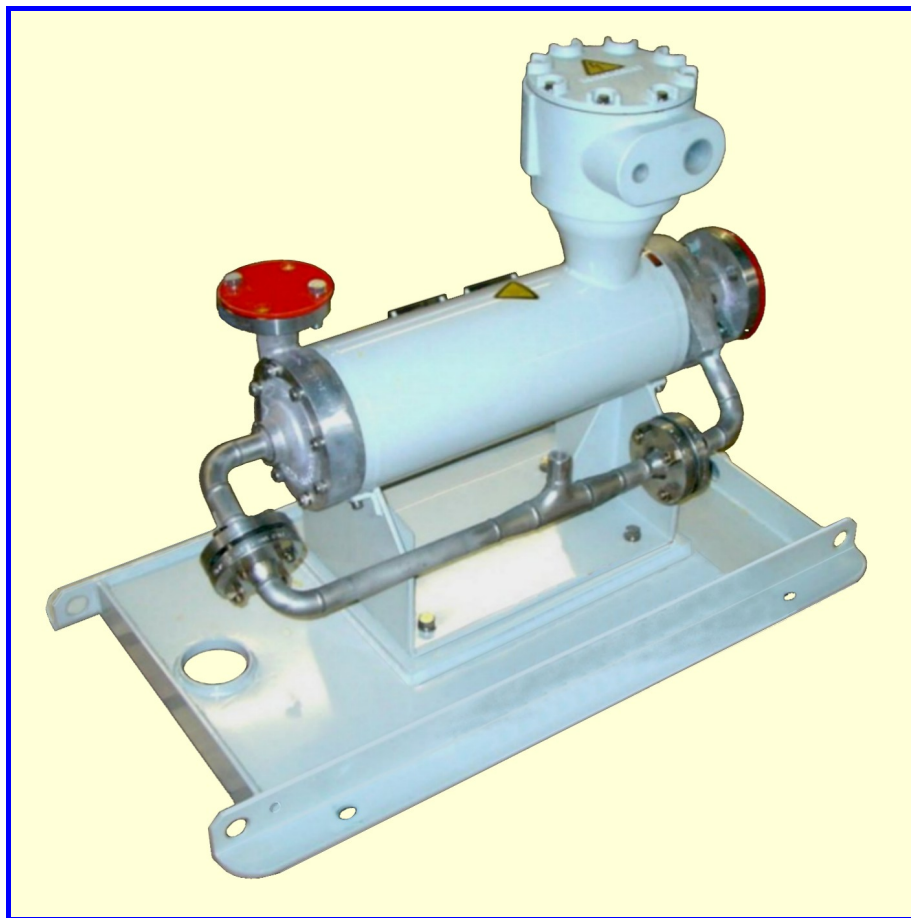

HK - Series



High head - High speed

Capacity	max. 14,5 m³/h
Head	max. 290 m
Speed	max. 8400 rpm

HK -Series

General

Nikkiso HK-Series canned motor pumps are centrifugal pumps, which due to their construction are hermetically encapsulated, they are of two stage design, in tandem arrangement. The shaft seal usually required on centrifugal pumps is not necessary. The pumps are driven by integrated canned motors. Space requirements and noise emissions are much lower than those of conventional centrifugal pumps.

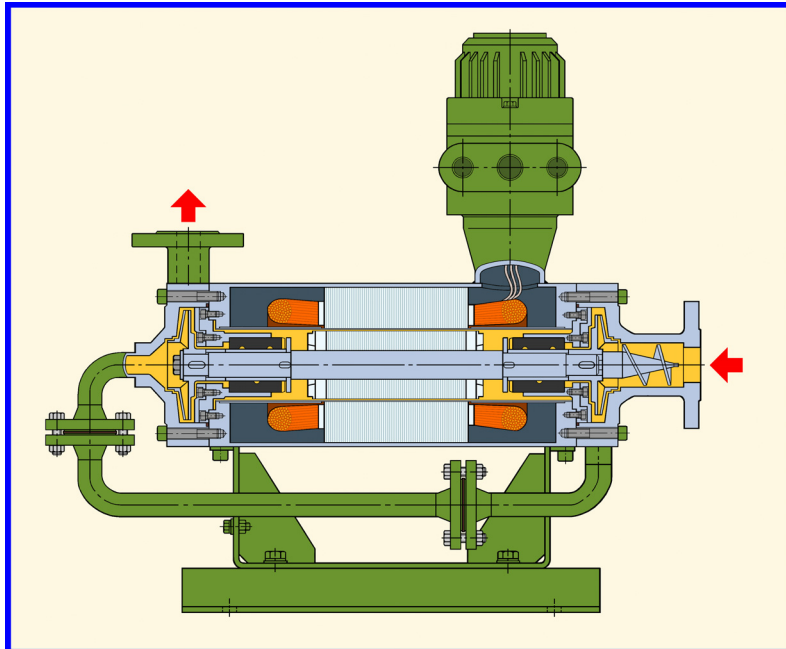

- Compact size
- Speed control by external frequency inverter (can be supplied by Nikkiso)
- Axial thrust balanced for long bearing life
- Spare parts interchangeable with SGM-Series (B-Motor)
- Low NPSH R

Applications

Nikkiso HK-Series canned motor pumps can be used with numerous liquids, also offers advantages over conventional pumps when pumping water. HK-Series pumps are mainly used for aggressive, inflammable, explosive and toxic clean liquids.

The pumps are designed for use in vacuum systems.

- High pressure water and chemicals
- Reverse Osmosis
- Ammonia, Ammonia water solutions

Pressure / Capacity Envelope

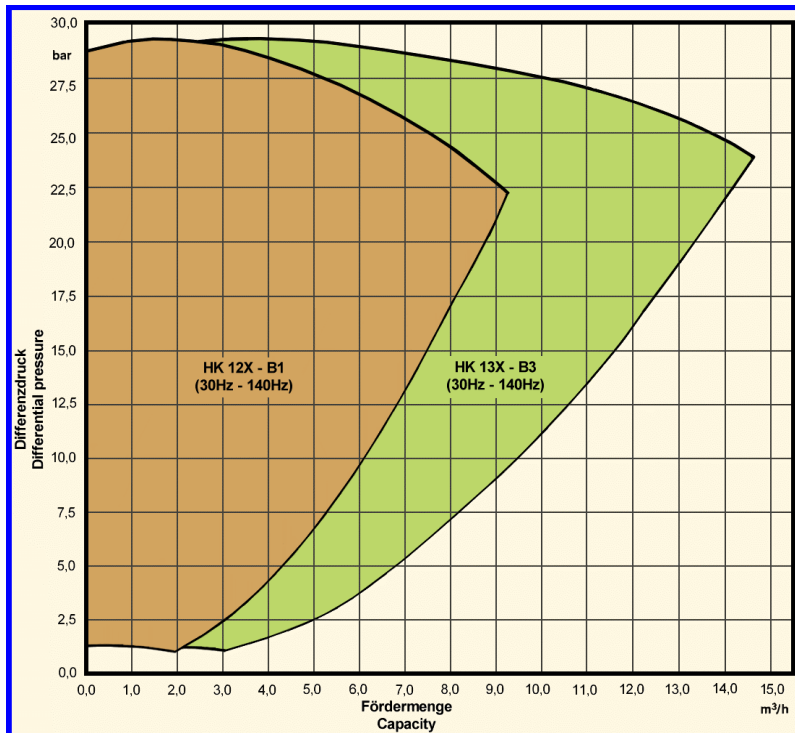

Materials (Standard design)

Part	Code
Casing(s)	1,4408
Impeller	1,4401
Gaskets	PTFE
Bearing housing	1,4401
Bearing	Special Carbon or SiC
Shaft sleeves	1,4401 / HCR
Thrust washer	1,4401 / WC
Motor housing	1,0040
Stator shell	1,0040
Can	Hastelloy
Rotor/Stator end cover	1,4401
Base / Motor support	1,0040

Other materials on request

Driver

- Integral 3-phase asynchronous motor IP67 / IP65 and flame proof acc. to ATEX 100a (94/9/EC).
- The motors are in accordance with VDE/EN requirements.
- Thermal winding protection