

seepex.com
all things flow

Here is your conveying solution:
Product group T, range BTEI.



T – Open hopper pumps, range BTEI

The BTEI range is a further development of the proven BTI and BTE ranges. In addition to a bridge breaker/mixing device, it features a supply tank that can be adapted to the application conditions on site. This supply tank replaces a separate storage tank and thus saves space within the system.

Storage hopper
dimensions and fill volume adaptable to individual conditions.

Shaft sealing
gland packing, alternatively with seal cage ring or grease chamber ring.

Bridge breaker drive
designed with a geared motor or variable speed drive in footmounting design, with elastic coupling and guard.

Pressure branch
with gauge connection. Flange connections alternatively to DIN or ANSI.

Stator
the seal on both ends is moulded as an integral part of the elastomeric stator; corrosion of the stator tube is never a problem because the pumped liquid never comes into contact with the metal tube or the bonding adhesive. Available with optional adjustable stator retensioning device.

Rotor
wear resistant and corrosion-proof materials, with additional surface treatment.

Tie bolts/screws
corrosion proof, optional available in stainless steel design.

Universal joint sleeve protection
made of stainless steel, protects the universal joint sleeve against mechanical damage from large or angular solids.

Coupling rod
with ribbon screw for power transmission and optimal product feed.

Compression zone
with flanges at both ends for quick dismantling when replacing the rotor, hand hole upon request.





Paddle shaft
 counter rotating shaft pushes the product into the auger to prevent bridging.

Shaft sealing
 gland packing, alternatively with seal cage ring or grease chamber ring.

Plug-in shaft connection
 for easy dismantling of the pump and drive enabling quick replacement of the rotating parts and shaft seals. The plug-in shaft pin secures the shaft connection to the drive and the splash ring protects the bearing from contamination/ gland leakage.

Pump drive
 geared motors, variable speed drives or frequency-controlled drives available from a variety of manufacturers. Drives and motors can be directly flanged to the pump without additional couplings; space-saving helical bevel drives are also available.

Lantern
 for connection of pump and drive and to secure the assembly to the baseplate.

Universal joint
 consisting of just 5 components. Power transmission through wear resistant, hardened and replaceable joint parts: easily repaired.

Universal joint sleeve with holding bands
 protects the grease-filled joints from penetration of the liquid pumped, even in case of maximum vacuum or pressure loading; streamlined design to reduce turbulence and NPSHr.

Detail: Arrangement of coupling rod and paddle shaft

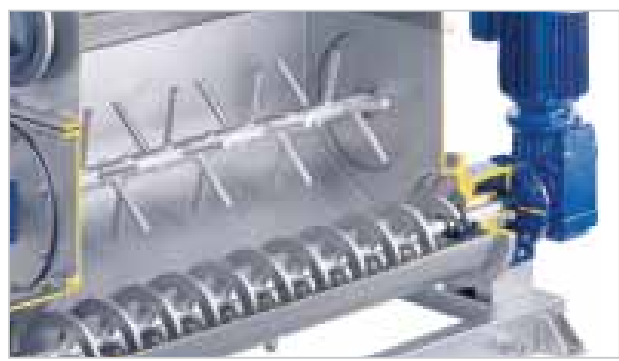

Why range BTEI?

Because they are used in applications such as construction, dyeing and varnishing industry, dewatered sludge treatment, shipbuilding, sludge dewatering, stock preparation, textile industry, utilities/disposal and waste water, wood processing and sludge treatment.

Features

- These pumps incorporate an open hopper and auger feed screw which enables highly viscous products to be fed into the pumping elements
 - The pitch and diameter of the auger can be adjusted according to operating conditions for optimal product feed
 - Supply tank for buffering the medium
 - Compression housing dismountable for service work
- > Conveying capacity: 0,5 m³/h–100 m³/h (2.2 GPM–440 GPM),
Pressure: up to 36 bar (540 psi)

Overview of ranges

Due to low investment costs and the ease in upgrading older plants with this new technology, the BTEI becomes the perfect choice for many sludge-incineration applications in power plants as there is less impact on the environment in disposing of sewage sludge in this manner.

These plants are fully automated with various measurement and control devices. Optionally available ultrasonic level measurement integrated in the BTEI storage hopper guarantees consistent product level and continuous feed.

Range BTEI

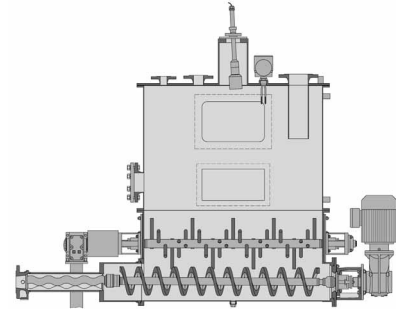

seepex.com
all things flow

And what can we get flowing for you? Your nearest contact:

Or visit www.seepex.com

BTEI 8.06E