

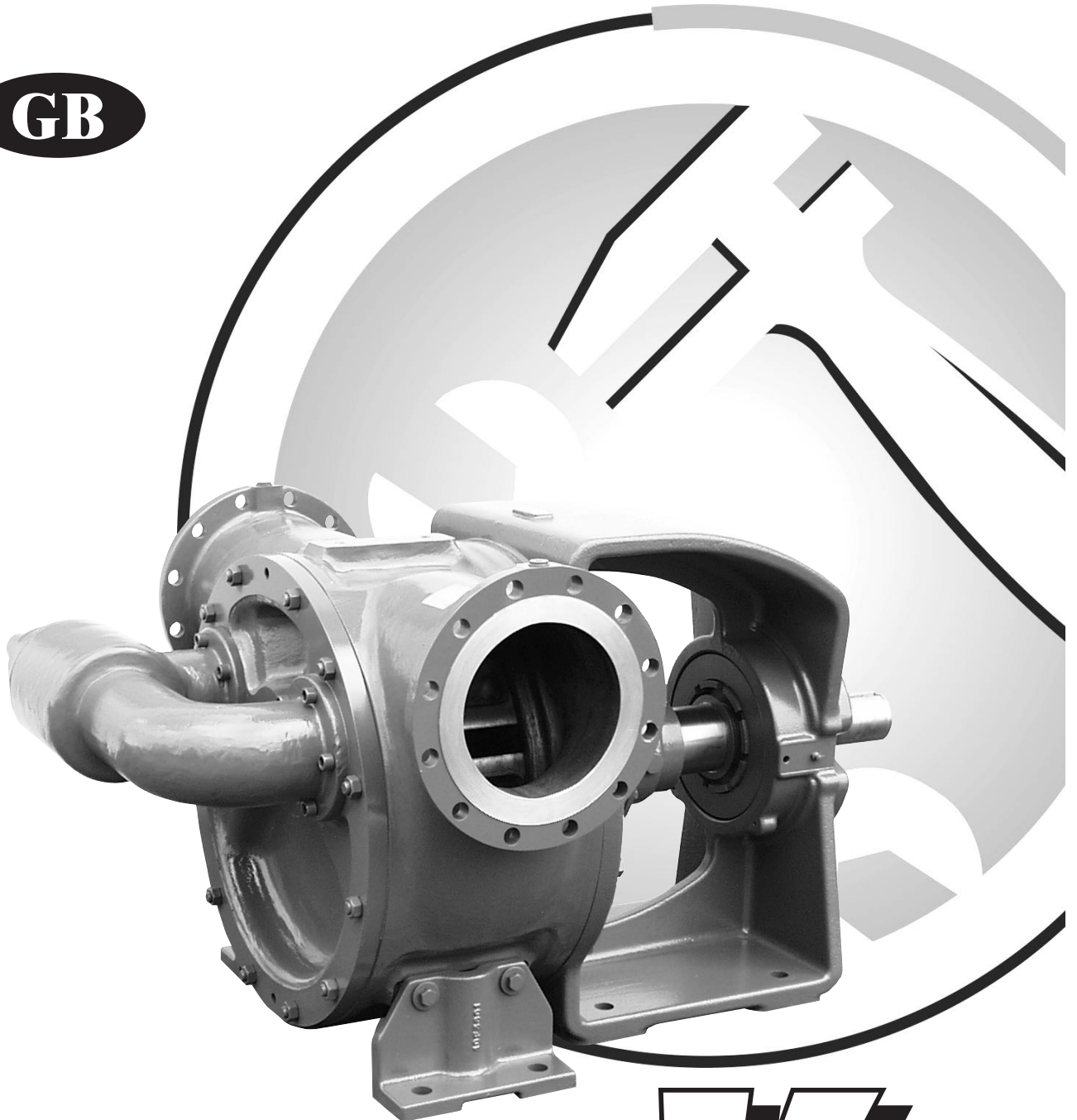

# varisco®

a solid name in fluids

**GB**



**Instructions for the  
installation, use and  
maintenance of pumps**

**V Series**



**Before starting the pump read this instruction manual carefully**

If the instructions for use and maintenance are observed, the pump will give full performance for a long time. This manual also contains information for the prevention and elimination of most common operating problems.

The following instructions are valid in general for the installation, use and preventive maintenance of all V series internal gear pumps. For special pumps, further information may be supplied with the pump as necessary. Note should be taken of the pump model and serial number. They must be quoted when requesting information or spare parts.

Pump type \_\_\_\_\_ Serial number \_\_\_\_\_

# CONTENTS

<b>1 IDENTIFICATION</b> .....	Pag. 4
1.1 Manufacturer .....	4
1.2 Type of pump .....	4
1.3 Instruction book identification .....	4
1.4 Nameplate information .....	4
1.5 Field of application .....	4
1.6 In case of breakdown .....	4
<b>2 WARRANTY</b> .....	4
<b>3 GENERAL INSTRUCTIONS</b> .....	4
<b>4 SAFETY AND ACCIDENT PREVENTION INFORMATION</b> .....	5
<b>5 IN CASE OF EMERGENCY</b> .....	5
<b>6 HANDLING AND TRANSPORT</b> .....	5
6.1 Method of transport .....	5
<b>7 INSTALLATION</b> .....	5
<b>8 STARTING</b> .....	7
<b>9 OPERATING PROBLEMS</b> .....	7
9.1 The pump fails to prime .....	7
9.2 Low capacity .....	7
9.3 Excessive pump noise .....	8
9.4 Motor overload .....	8
9.5 The pump wears out quickly .....	8
<b>10 ROUTINE MAINTENANCE</b> .....	8
10.1 Lubrication .....	8
10.2 Packed gland seal .....	9
10.3 Mechanical shaft seal .....	9
10.4 Axial rotor adjustment .....	9
10.3 Regulation of the by-pass relief valve .....	9
<b>11 DISASSEMBLY</b> .....	9
11.1 Removing the cover .....	10
11.2 Removing the idler .....	10
11.3 Removing the idler pin .....	10
11.4 Removing the casing .....	11
11.5 Removing the ball bearings .....	11
11.6 Removing the packed gland (cast iron pumps from V6 to V25) .....	11
11.7 Removing the packed gland (cast iron pumps from V25-2 to V200) .....	11
11.8 Removing the ST5, ST6 mechanical seal (cast iron pumps from V6 to V25) .....	11
11.9 Removing the ST4, ST5, ST6 single mechanical seal .....	12
11.10 Removing the ST7 double mechanical seal .....	12
11.11 Removing the ST8 double mechanical seal .....	12
11.12 Removing the shaft bush .....	12
11.13 Removing and disassembling the by-pass relief valve .....	12
<b>12 ASSEMBLY</b> .....	13
12.1 Mounting the ball bearing .....	13
12.2 Mounting the shaft bush .....	13
12.3 Mounting the shaft and rotor .....	13
12.4 Mounting the ST5, ST6 mechanical seal (cast iron pumps from V6 to V25) .....	13
12.5 Mounting the ST4, ST5, ST6 mechanical seal .....	13
12.6 Mounting the ST7 double mechanical seal .....	14
12.7 Mounting the ST8 double mechanical seal .....	14
12.8 Mounting the bushes .....	15
<b>13 STORAGE</b> .....	15
<b>14 SPARE PARTS</b> .....	15
<b>15 DISPOSAL</b> .....	15

# 1 IDENTIFICATION

## 1.1 Manufacturer:

VARISCO POMPE Srl Zona Ind. Nord - Terza Strada, 9 - 35129 PADOVA - Italy

## 1.2 Typ of pump

Self-priming gear pump.

## 1.3 Instruction book identification

Prepared: January 2002 Edition: 04 Rev. 00 Date of revision :

## 1.4 Nameplate information

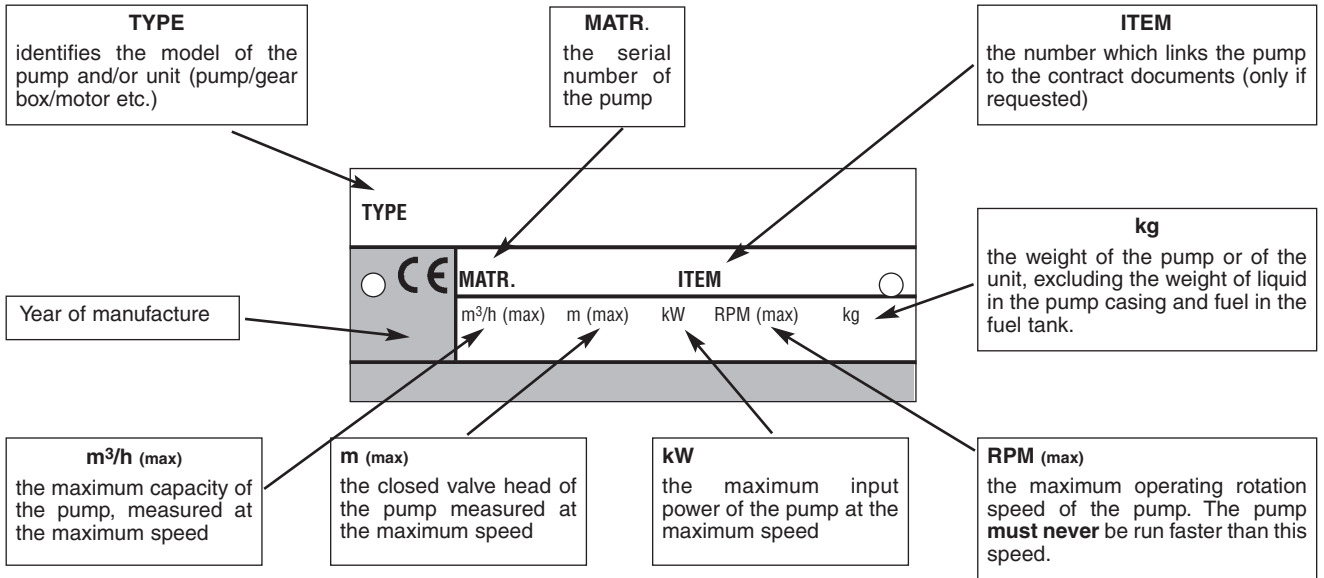

The values shown for the capacity (m³/h), head (m), power (kW) and speed (RPM) refer to testing with oil at 20°C and 100 cSt.

## 1.5 Field of application

The pumps are suitable for handling liquids of viscosity up to 100 000 cSt.

## 1.6 In case of breakdown

Contact the nearest Varisco distributor (see list below) or the Varisco factory:

Phone: + 39 049 82 94 312

Fax: + 39 049 80 76 762

# 2 WARRANTY

- The manufacturers guarantee that only high quality materials are used in the construction of their pumps and that machining and assembly are carried out to high standards.
- The pumps are guaranteed against defective materials or faulty workmanship for a period of one year from the date of delivery unless specifically stated otherwise in writing.
- **The warranty is not valid if the pump has been tampered with by third parties.**
- Replacement of parts or of the pump itself can only be carried out after careful examination of the pump in an authorised workshop by qualified personnel. The pump should be sent carriage paid.
- This guarantee does not cover parts subject to deterioration or normal wear and tear (seals, diaphragms, pressure and vacuum gauges, rubber or plastic items, etc.) or damage caused by misuse or improper handling of the pump by the end user.
- Parts replaced under guarantee become the property of the manufacturers.

Date .....

# 3 GENERAL INSTRUCTIONS

The goods must be examined on arrival to ascertain any damage caused during shipment. Loss or damage must be notified immediately to the carriers and to the sender. Check that the goods correspond exactly to the description on the shipping documents and report any differences as soon as possible to the sender. Always quote the pump type and serial number stamped on the nameplate.

**The pumps must be used only for applications for which the manufacturers have specified:**

- the construction materials
- the operating conditions (pressure, speed, temperature, etc.)
- the field of application

In case of doubt, contact the manufacturers or an authorised distributor.

+ 39 049 82 94 312

## 4 SAFETY AND ACCIDENT PREVENTION INFORMATION

When working near the pump, dress appropriately, avoiding clothes with loose items (ties, scarves, etc.) which could get caught in moving parts. Use overalls made according to safety regulations, gloves, insulating shoes, safety glasses, ear plugs and helmet (fig.1).

- Do not carry out maintenance on the motor while it is running.**
- Keep hands away from moving parts (e.g. belts, couplings, etc.).**
- Keep hands away from hot areas of the engines.**
- Do not mount on the pump to carry out maintenance operations of any kind.**

## 5 IN CASE OF EMERGENCY

Shut down the motor.  
Notify the person responsible for running the plant immediately.

## 6 HANDLING AND TRANSPORT

### 6.1 Method of transport

The pump must be transported in the horizontal position and stowed safely. During installation and maintenance, all the components used must be handled and transported securely by using suitable slings. Handling must be carried out by specialised personnel to avoid damage to the pump and to persons. The lifting rings attached to various components should be used exclusively to lift the components for which they have been supplied.

Figure 2 highlights in black the lifting points of some typical base plates.

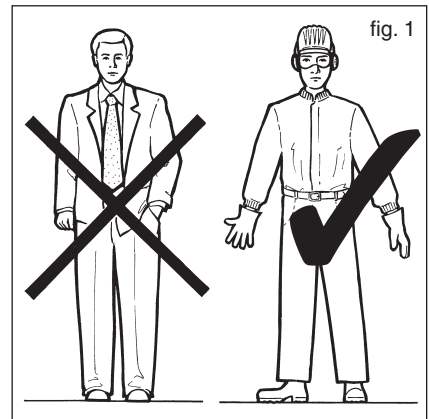

Maximum lifting speed:  $V_{max} \leq 0,5 \text{ m/s}$

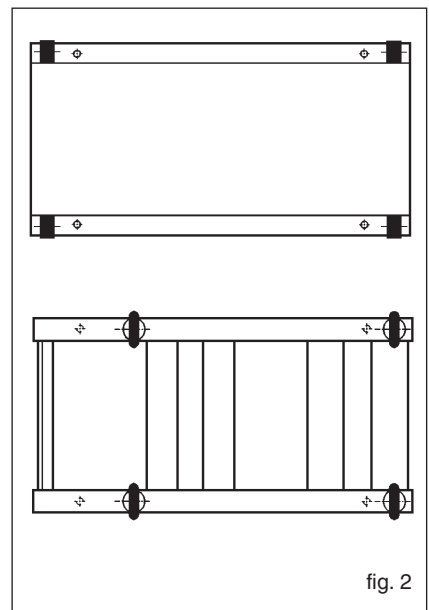

## 7 INSTALLATION

- 7.1 The pumps are tested and the by-pass (if fitted) set with a liquid which also serves to protect the internal surfaces for 6 months from date of shipment.  
This liquid is a mixture of oil and passive neutral detergent; if this liquid could pollute the product to be pumped, it is necessary to wash out the pump before installation. **Do not pump water for any reason, or leave traces of water in the casing.**
- 7.2 Install the pump as near as possible to the source of the liquid to be pumped leaving sufficient space for access for inspection and maintenance. In particular, space is required in front of the pump for removing the cover, near the gland for replacing the packing, near the oil discharge plug of the gear box (if fitted) and on the terminal box side of the electric motor.
- 7.3 Identify the suction and discharge ports before installation. V series pumps are totally reversible: the direction of flow can be inverted by changing the direction of rotation of the shaft. This means that the suction and discharge ports are not fixed at the outset but can be interchanged. If a by-pass relief valve is fitted, however, it operates only in one direction of flow (see paragraph 7.4).

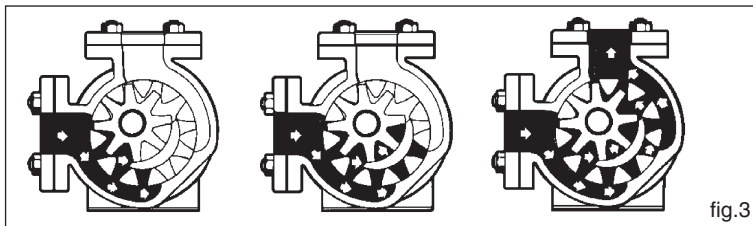
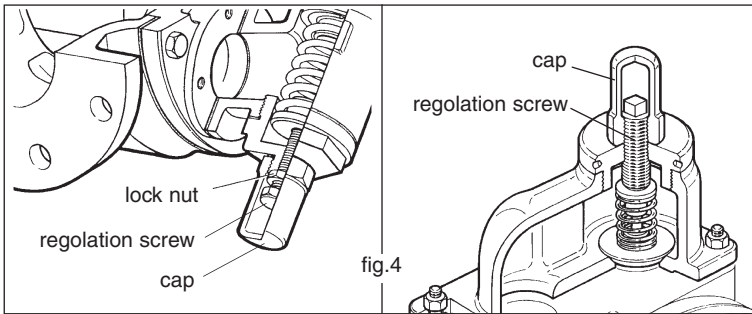

Figure 3 shows the flow path of the liquid inside the pump; as the gears open, liquid is drawn into the pump and this area is therefore near the suction port. The liquid is carried between the gears and the crescent and is expelled from the discharge port as the gears mesh.

- 7.4 It is always advisable to mount a by-pass relief safety valve which can be supplied and mounted even after the pump has been installed. If for any reason the discharge line should be blocked when the pump is operating, the pressure generated can reach very high levels, endangering the transmission or the pipework joints. The relief valve is mounted externally on the pump cover or casing and can be set from outside.



With reference to figure 4, the force exercised by the spring on the valve can be increased or decreased by means of the regulation screw under the cap. When the pressure generated by the pump acts on the lower face of the valve plate with a force equal to the thrust of spring, the valve begins to open. The pressure at which this happens is called the “cracking pressure”. The liquid begins to flow through the by-pass towards the suction side. The full flow capacity depends on a pressure which is a function of the pump rotation speed and the viscosity of the liquid. The cracking pressure is the pressure setting of the relief valve.

Unless otherwise specified, the by-pass is set at 2 bar.

Full flow through the by-pass is reached at an average over pressure of 15% of the cracking pressure.

The by-pass safety relief valve can be mounted on the pump cover or on top of the casing. In the first case, the regulation screw cover cap must be on the suction side of the pump while in the second case (stainless steel pumps) it must be on the discharge side.

If the pump is often used in both directions of rotation, it is advisable to mount a double by-pass, available in request, which can be fitted in the place of a single by-pass.

**NB:** Do not use the pressure relief valve as a flow regulation device (for example in filling system with a nozzle, in dosage plant, etc). The liquid which circulates through the pump is subject to heating and this reduces the lubrication of the moving parts, especially of the idler bush. Furthermore, the liquid may vaporize or form incrustations. In these cases, a return to tank line with a spring valve or other type of valve must be fitted to the pipework, or a system to regulate the pump rotation speed installed. The pressure relief valve should therefore be used only as a safety valve to prevent damage to the pump or pipework due to excess discharge pressure.

If it is not possible to fit a relief valve, a system which breaks the power transmission between the motor and pump, such as a torque breaker coupling. Torque converters are not suitable for this purpose; they only ensure smooth start up of the pump. AT and AW model pumps for abrasive liquids cannot mount a by-pass because they are not suitable for products which wear out the valve seat.

- 7.5** The base plate on which the unit is mounted must be sufficiently robust and should absorb vibrations rather than cause or amplify them. Steel base plates supplied by Varisco meet these requirements. The foundation on which the base plate is to be mounted should be perfectly level and at least 50-100 mm wider than the base plate. To avoid deforming the base plate, shims should be added to the anchor bolts as necessary. Anchor bolts, whose shapes are specified by size in proportion to the holes on the base plate. Check the alignment of the unit after tightening the anchor nuts and before connecting the piping.
- 7.6** The pipework must be suitably sized to ensure that the pump operates with the required performance. Most problems are due to the suction line. Other sections of this manual contain information for sizing the pipework. The following are some of the most important points:
- 7.6.1** The diameter of the pipes must be less than that of the pump ports.
- 7.6.2** Ensure that the pipes are clean and do not contain foreign bodies such as nuts, screws, rags, welding slag, pieces of electrodes, etc.
- 7.6.3** Mount a non return valve in the piping to avoid having to fill it every time the pump is started. If the pump operates on a suction lift, install a foot valve which is large enough not to create excessive friction losses.
- 7.6.4** The suction pipe must have a diameter equal to or greater than that of the pump suction port and should not have upward bends where air pockets can form.
- 7.6.5** The joints of the suction pipe must be perfectly airtight: use flanged joints or threaded joints with teflon tape or tow on the threads. During pumping, the pressure in the suction pipe is lower than atmospheric if the pump operates on suction lift. This means that any leaks in the pipe will not cause liquid to drip from the pipe but air will be drawn in through the leaks which is more difficult to detect.
- 7.6.6** It is recommended that pressure and vacuum gauges be installed to check the pressure. Most V pump models have connections near the suction and discharge flanges for mounting gauges.
- 7.6.7** Install a filter in the suction line to intercept any impurities or foreign bodies in the liquid which could damage the pump. The filter basket must have a free passage surface losses on the suction side of the pump. Special care should be taken when filtering high viscosity liquids: it is better to oversize the filter. The filter screen holes must be sized so as not to impede the operation of the pump. The following table shows the maximum size of the filter screen holes for the various pump models:

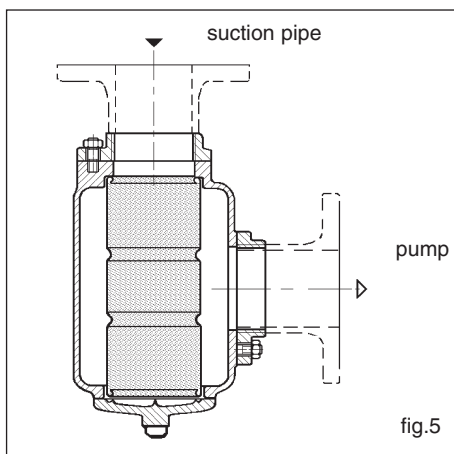

The filter should be installed in such a way that it is easy to clean. Take care during installation that the direction of flow is that indicated by the manufacturer. The liquid should always flow from the inside towards the outside of the basket.

Varisco makes filters with replaceable basket which can be opened without tools (figure 5). The drawing shows the recommended mounting position in which the filter basket can be quickly cleaned.

Pump size	Max size (mm)
V20, V25, V25-2, V30-2, V50-3, V60-2, V70-2, V80-2, V85-2, V90-2, V100-2	0,8
V120-2, V150-2, V151, V180, V200	1

## 8 STARTING

During pump start up, particular attention should be paid to the following points to avoid costly mistakes.

### Before starting the pump, check the following:

- Check the alignment of the pump, gear box (if fitted) and motor
- Check that the filter and pipework are free of welding scale and metal shreds
- Check that the joints are well tightened.
- Check that the pipework does not weigh too heavily on the pump casing. See the maximum permitted nozzle loads in the first part of the Technical Manual. If the liquid can reach high temperatures, check that expansion joints are fitted in the pipework.
- Verify the electrical connections and rating of the motor and check its direction of rotation.
- Check that the direction of rotation of the pump is correct. See the first part of the Technical Manual.
- The by-pass relief valve, if fitted, must be correctly mounted. See paragraph 7.4.
- Check that the pump shaft is free to rotate.
- The inside of the pump should not be dry, especially if it must self-prime. Fill or wet the internal parts with oil, the liquid to be pumped or with a liquid compatible with the pumped liquid. During assembly, the pumps are protected with a passivating oily liquid. If this is not compatible with the pumped liquid, the pump must be disassembled and cleaned (see paragraph 7.1)
- Fit the connections for pressure and vacuum gauges.
- Check that the mechanical seal quench is full of oil.
- Do not test V series pumps with water.
- Before pumping liquids other than that for which the pump was sold, consult the Technical Manuals and other company literature or consult our Sales Department.
- Check that all valves are open.
- If the pump is powered by an internal combustion engine, start the engine with the clutch disengaged.
- After starting the pump, check that liquid has entered it and that the pump is operating correctly. If after one minute the pump is still running dry, stop the pump and check pump and pipework as described under paragraph 9.1.

## 9 OPERATING PROBLEMS

If operating problems are experienced, either on start up or after the pump has run for some time, proceed as follows before opening the pump:

- Check that the liquid inside the pump is not under pressure
- Ensure that the pump does not start up by mistake or through automatic controls (disconnect the motor power supply)
- Read the following instructions carefully

### 9.1 The pump fails to prime

- Wrong direction of rotation
- No liquid in the pump to create a seal between the gears and the casing. The suction gauge hardly moves or else oscillates. If the pump is required to self-prime at every start up and has difficulty in priming, it is advisable to fit a "goose neck" or a foot valve in the suction line to ensure that there is always liquid in the pump.
- Suction valve closed, suction line or filter clogged. The vacuum gauge reading is high.
- Air leaks in the suction line : check gaskets, threads and welds. Attention : It is not easy to trace air leaks in the suction pipework. Listen for the characteristic hiss of air leaks near the joints.
- The pump cannot expel the air through the discharge line. Check that all the valves are open; if necessary, bleed the delivery pipe.
- Excessive suction lift, especially when pumping liquids with high vapour pressure. Install the pump on flooded suction.
- Low rotation speed.
- By-pass relief valve blocked in the open position by impurities.
- Suction tank empty.
- Pump cover installed in the wrong position.

### 9.2 Low capacity

- Rotation speed too low for the required capacity.
- Suction line or filter clogged or valve closed. The vacuum gauge reading is high. Metallic cavitation noise.
- Air leaks in the suction line. The vacuum and pressure gauges oscillates. Check the suction line.  
**Attention: It is not easy to trace air leaks in the suction pipework. Listen for the characteristic hiss of air leaks near the joints.**
- The by-pass relief valve is set at too low a pressure causing some of the liquid to recirculate inside the pump. Tighten the regulation screw (see paragraph 10.5); the pressure gauge will show a higher pressure.
- Air pockets may have been formed in the suction line, especially if the pipework includes vertical bends.
- The liquid vaporizes before entering the pump, especially when trying to pump liquefied gases or liquids with high vapour pressure on suction lift. The static suction lift is too high.
- The suction pipe is not sufficiently immersed in the liquid allowing air to enter the suction line. The vacuum gauge oscillates. The pipe must be immersed in the liquid to a depth of at least twice the diameter.
- The liquid is too viscous for the rotation speed of the pump. The vacuum gauge reading is very high and a metallic noise comes from inside the pump. Reduce the liquid viscosity by heating, reduce the rotation speed of the pump or increase the diameter of the pipework.
- The pump cover is mounted in the wrong position.



### 9.3 Excessive pump noise

- Not enough liquid reaches the pump because the viscosity is too high. Reduce the rotation speed, increase the diameter of the suction pipework, reduce the friction losses in the suction line.
- The pump cavitates because the liquid is too volatile. Increase the diameter and/or reduce the length of the suction line. Raise the level of the liquid in the suction tank; if necessary mount the pump on flooded suction.
- Check the alignment of the flexible couplings.
- The by-pass relief valve vibrates: tighten the regulation screw.
- Check the anchorage of the base plate and the pipework supports.
- Foreign bodies in the pump.
- The cover is mounted at 180 degrees compared with the correct position.

### 9.4 Motor overload

- High rotation speed.
- High viscosity: reduce the rotation speed as shown in the performance tables or heat the liquid.
- High pressure: increase the diameter of the delivery line and check that all valves are open and that the pipe is not clogged. Do not exceed the pressure shown in the table.
- Packing too tight. Loosen the gland screws until the correct drip rate is reached.
- Check the pump alignment. (If this the problem, noise will also be generated).
- Tolerance too tight for the liquid to be pumped. The bushes overheat and seize, and the extremity of the idler pin on the cover heats to over 80 degrees C. Stop the pump and increase the tolerances as indicated by Varisco.

### 9.5 The pump wears out quickly

Rapid wear of the pump causes a sudden drop in performance. The following are the main causes and how to put them right.

- The liquid is abrasive or contains solids. Grooves are present on the surfaces, the bushes wear out rapidly, the clearances increase and the surfaces are irregular.
- Clean all the pipework thoroughly and install a suction filter. If the liquid is abrasive, reduce the rotation speed. Reduce the delivery pressure. Use the AT version.
- Corrosion, shown by the formation of rust, porosity or pitting on the surfaces and damage to elastomers.
- Check that the materials used are those best suited to the application and check that the liquid has not been contaminated in such a way as to become corrosive. Check that the concentration has not changed and/or that the liquid temperature is within the permitted range.
- The operating limits have been exceeded. This is shown by excessive, broken bushes, bent or broken shaft vibrations etc. Use a larger pump chosen from the catalogue.
- Tight tolerances. This is shown by pump seizure, overheating, breakage of or damage to bushes, and motor overheating, breakage of or damage to bushes, and motor overload. Increase the clearances after consulting Varisco and giving full details on the application and duty.
- Lack of lubrication causing noise, heating and rapid wear of the external pedestal bearing and wear of the oil seal, or noise in the gear box. Ensure that the ball bearing is lubricated as directed in paragraph 11.1. Ensure that the gear box is lubricated as instructed.
- Misalignment. This is shown by non uniform wear (wae on one side of the casing, of the packing or of the cover). The possible causes are deformation of the casing due to the weight of the pipework, misaligned flexible coupling, excessive belt tightening or base plate out of plane.
- Check the alignment of the pump and drive under conditions as near as possible to those of operation. Support the pipework and check the type of belts.
- Dry running and pump seizure due to the deformation of internal components, overheating and colour changes caused by excessive heat.
- Ensure that liquid is present, mount a foot valve when starting the pump or install an adequate alarm system or motor cut out when the pump runs dry.

## 10 ROUTINE MAINTENANCE

### 10.1 Lubrication

The external pedestal bearing has a grease nipple. Lubricate the bearing with suitable grease (MOBILUX EP2, AGIP GR MU EP2, IP ATHESIA EP2 or equivalent) every 500 hours of operation or every two months, or more frequently if the pump duty so requires. Do not use excessive quantities of grease.

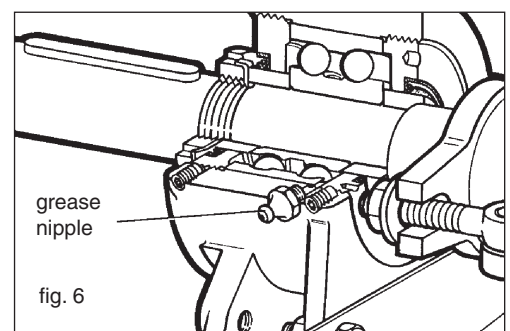

### 10.2 Packed gland seal

If the drip from the gland is excessive, tighten the gland screws gradually without overtightening.

During operation, liquid must leak through the packing for lubrication and cooling. If the leak is excessive, replace the packing or use another type of packing. If the loss of liquid is too dangerous because of corrosion or fire hazard, a mechanical seal must be fitted.

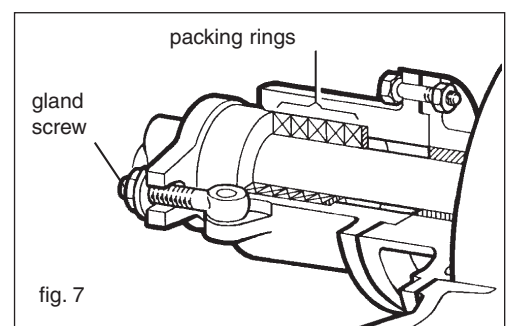



### 10.3 Mechanical shaft seal

If the pump has a reservoir for quench liquid (such as option +O2), check that the level of liquids is approximately 3/4 of the reservoir volume. The liquid in the reservoir must be compatible with the pumped liquid. Unless otherwise specified, the shaft seal gaskets are PTFE.

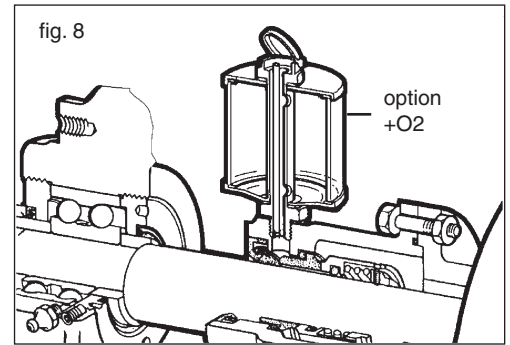

### 10.4 Axial rotor adjustment

After many hours of operation, the clearance between the rotor and cover can increase causing loss of capacity and pressure. It is possible to take up part of the clearance by adjusting the lock rings which fix the external ball bearing.

To adjust the lock rings, use a prong spanner.

- Loosen the security dowels.

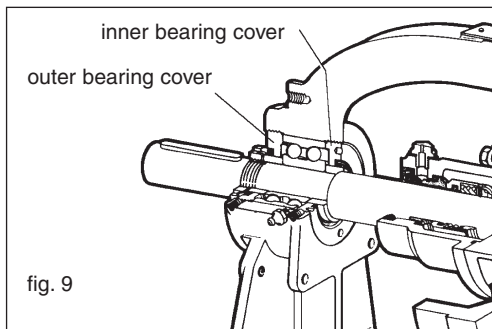

Pump type Class	V25-2 V30-2	V50-3 V60-2 V70-2 V80-2	V85-2	V90-2 V100-2	V120-2 V150-2 V151	V180 V200
	1	$\frac{1}{8}$ 0,187	$\frac{1}{8}$ 0,25	$\frac{1}{6}$ 0,3	$\frac{1}{4}$ 0,5	$\frac{1}{4}$ 0,5
2	$\frac{1}{4}$ 0,37	$\frac{1}{4}$ 0,5	$\frac{1}{3}$ 0,7	$\frac{1}{3}$ 0,7	$\frac{1}{3}$ 0,7	$\frac{2}{3}$ 1,5
3	$\frac{1}{3}$ 0,5	$\frac{1}{3}$ 0,7	—	$\frac{1}{2}$ 1,0	$\frac{3}{4}$ 1,5	$\frac{3}{3}$ 2

- Loosen the internal lock ring
- Tighten the outer lock ring as far as it will go.
- Loosen the outer lock ring as shown in the table below.
- Tighten the inner lock ring and fix the security dowels.

**Note:** In the models V 120-2, V 150-2, V 151 and V 200 only the internal lock ring is fixed and the following two operations should be carried out:

- Loosen the outer lock ring by 1/8 of a turn
- Fix the security dowel (models V25-2 and V30-2 do not have security dowels).

.K pumps and Packed gland	Others	Viscosity
Class 2	Class 1	up to 600 cSt and up to 180 deg C (1)
Class 3	Class 2	from 600 to 6000 cSt and up to 180 deg C
Class 3	Class 3	over 6000 cSt and over 180 deg C

**Note:** The upper figure is the fraction of a turn of the outer lock ring while the lower figure is the corresponding distance in mm between the rotor and cover.

### 10.5 Regulation of the by-pass relief valve

(Example of setting not 8 bar)

The by-pass must be set with the pump in operation

- Unscrew the cap
- Loosen the lock nut (if fitted).
- Tighten the regulation screw almost as far as it will go (turn the screw clockwise to load the spring).
- Adjust the delivery valve of the piping system until the pressure gauge reading on the delivery side is the required setting (in our example, 8 bar).
- Loosen the regulation screw (turn it anticlockwise to unload the spring) until the pressure gauge reading starts to fall below the setting (eg 8 bar).
- At this point, the by-pass is set and the delivery valve can be opened to let the system operate normally.
- To reset the by-pass to a higher or lower pressure, follow the same procedure.
- When the spring is not compressed, the regulation screw can be freely unscrewed. It is not advisable to unscrew any further.

**Attention: It is essential to use caution when working with inflammable or corrosive liquids.**

## 11 DISASSEMBLY

If the pump is under warranty, do not disassemble without consulting the manufacturers or their authorized representative. If this is not observed, warranty will not apply.

Before opening the pump, ensure that:

- the liquid inside is not under pressure
- if liquefied gas is being pumped, that all the gas has been vented
- if not liquids are being handled, that the liquid has cooled.

For large, heavy pumps (eg V 100-2, V 120-2, V 151, V 150-2, V 180 and V200) adequate hoisting equipment is necessary to handle the components.

Ensure that machined surfaces are protected before hoisting or moving with cables or other devices.

**Do not use water to clean the pump and its components.** If this is inevitable, dry carefully and coat with oil.

### 11.1 Removing the cover (04) (see fig. 10)

- ❑ Unscrew the screws (43). Use the two threaded holes on the cover (if present) to facilitate removal of the cover.
- ❑ When removing the cover, take care not to damage the gasket (31). If this is damaged it should be replaced. Do not use damaged gaskets or gaskets with a thickness different from that of the original gasket.
- ❑ Slide the cover/idler assembly carefully out of the pump casing. Attention: when the cover is removed, the idler may fall off the idler pin if it is not held. This is a potential cause of accidents.

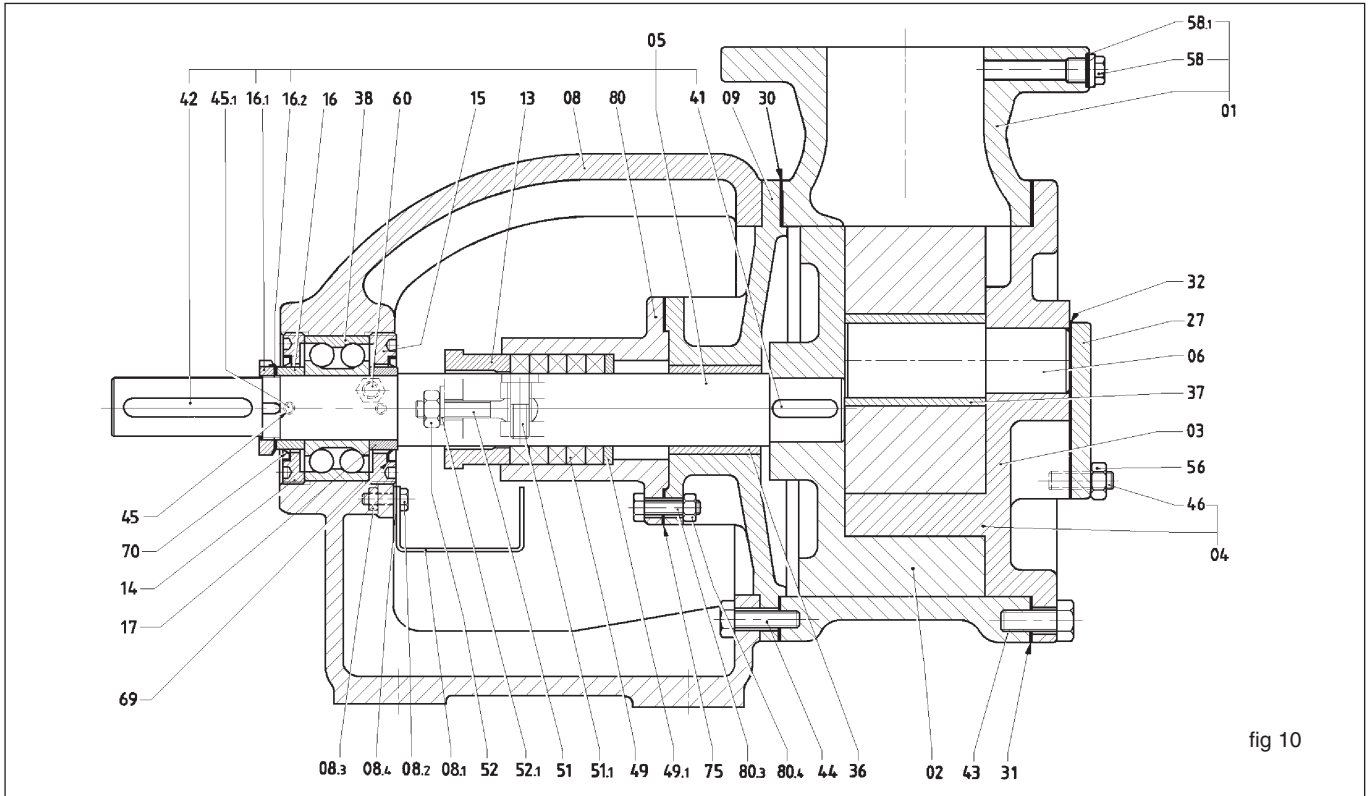

fig 10

- ❑ If the pump mounts a by-pass relief valve (figure 11) on the cover it is not necessary to remove it. If, however, the by-pass also requires maintenance, unscrew the screws (46) and remove it, taking care not to damage the gasket(s) (32). If the gaskets are damaged, replace them.
- ❑ If the pump mounts a heating jacket on the cover (option +R2 (07), this will separate from the cover as soon as the screws are removed (43), see figure 11.
- ❑ Take care not to damage the gaskets; if this should happen, replace it.
- ❑ If the cover/idler assembly does not require maintenance, go to paragraph 4.6.

### 11.2 Removing the idler (03) (see fig. 10)

- ❑ Slip the idler off the idler pin (06). The idler bush is fitted to the centre of the idler. (Some versions do not have an idler bush and mount a large diameter pin.)
- ❑ The idler bush can be supplied in various different materials. The choice of material depends on various factors such as the liquid to be pumped and the duty.
- ❑ Remove the used idler bush using a bench press. The bush is usually press fitted.
- ❑ Clean the bush thoroughly and check the surfaces for wear. Replace the bush if it has external or localized cracks, signs of abrasion, severe wear, deformation, external or localized blackening, rust, etc. The tolerances and clearances of the bush depend on the pump version and the specific application for which it is intended. It is therefore not advisable to replace bushes with other of similar dimensions or of different materials from the original. This could cause damage to the pump.

**Note:** the bushes play an essential role for the satisfactory operation of the pump. They have been designed and tested to ensure perfect contact between the idler and idler pin and between the shaft and the rear cover.

**Do not invent alternative solutions or try to repair the bushes by changing the tolerances or chemical and mechanical characteristics.**

- ❑ After removing the bush, clean the idler thoroughly and inspect the surfaces.
- ❑ If there are clear signs of severe wear or the hole is ovalized, replace the idler.
- ❑ Mount the new bush using a bench press with a steady movement. For the V180, V200, heat the idler to 80 deg C and mount the bush. Use a lathe to bring the hole up to tolerance as instructed by Varisco.

### 11.3 Removing the idler pin (06) (see fig. 10)

- ❑ The idler pin is fixed to the cover. The pin should be removed only if it needs to be replaced or when replacing the cover. It is not necessary to remove it to check the state of wear. The working surface where the idler bush runs sticks out completely from the cover.

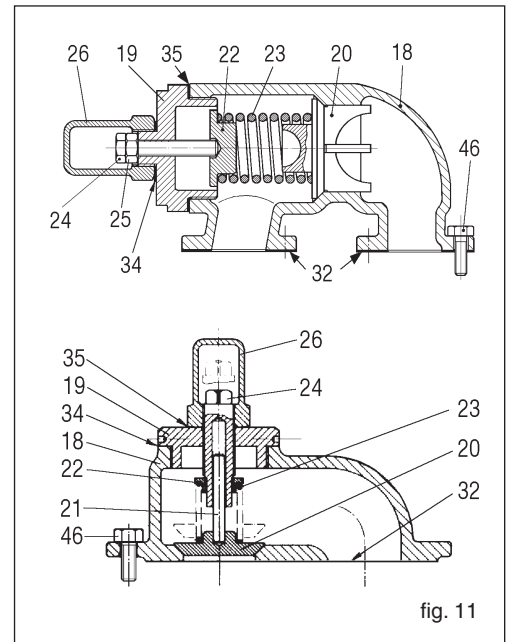

fig. 11

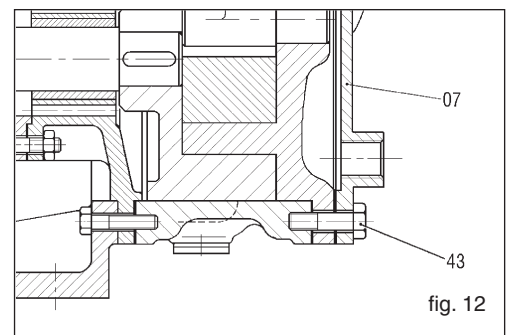

fig. 12

- Remove the idler pin from its seat using a press.
- If there are clear signs of wear, replace the idler pin. If the pin shows signs of overheating, this usually shows that the idler tends to gall. Check the idler bush and the idler thoroughly.

#### 11.4 Removing the casing (01) (see fig. 10)

- It is possible to remove the casing without dismantling the pump from its base plate. It is sufficient to remove the suction and discharge flange screws. If the pump mounts a jacketed casing or cover, the auxiliary heating (or cooling) liquid pipes should be removed.
- Remove the screws (44).
- Disengage the casing from the rear cover (09) taking care not to damage the gasket. If the gasket is damaged, replace it.
- The rear cover remains centred on the pedestal.
- Clean the casing thoroughly and check the state of wear.
- Replace if necessary.

#### 11.5 Removing the ball bearing (38) (see fig.10)

**Note:** Disengaging the shaft from the ball bearing in the pedestal requires great care at every step.

- Disconnect the pump from the flexible coupling or from the belt pulley.
- Remove the key (42) from its seat on the shaft (05).
- Unscrew the lock ring (16.1) after freeing it from the splines of the washer (15.2).
- Loosen the safety dowels (45).
- Remove the outer bearing cover (14) and the sleeve (15)
- Block the rotor to prevent the shaft from turning.
- Disengage the shaft seal as described below under paragraph 4.8 if a mechanical seal is fitted
- Force the shaft out of the bearing using a press. If a press is not available, use a bearing extractor. Bear in mind that the rotor (02), the rear cover (09) and the seal box (80) will also be removed together with the shaft.
- Unscrew the grease nipple (60), remove the inner bearing cover (15) and force the bearing out of the pedestal.

#### 11.6 Removing the packed gland (cast iron pumps from V6 to V25) (see fig. 13)

Loosen the cover (80.6) and free the gland (80).

- Remove the springs (80.5) and the washer (49.3).  
Using a packing extractor or a screwdriver and replace them after cleaning the gland thoroughly. Mount the new packing rings supplied as a spare part. If using packing not supplied as spare, prepare rings to a length equal to that of the outside diameter of the shaft with a cut at 45 degrees to the axis of the gland.
- Insert the packing rings with the cuts on opposite sides one to the other, settle them in and lubricate them.

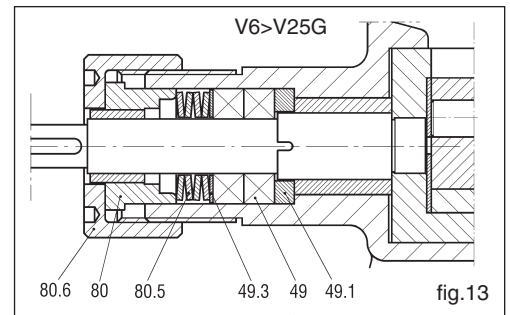

#### 11.7 Removing the packed gland (cast iron pumps from V25-2 to V200 and stainless steel pumps from V6 to V25) (see fig. 14)

Loosen the gland nuts (52) and free the gland (13).

- Remove the packing rings (49) using a packing extractor or a screwdriver and replace them after cleaning the gland thoroughly. Mount the new packing rings supplied as a spare part. If using packing not supplied as spare, prepare rings to a length equal to that of the outside diameter of the shaft with a cut at 45 degrees to the axis of the gland.
- Insert the packing rings with the cuts on opposite sides one to the other, settle them in and lubricate them.
- The SP1 version mounts an intermediate flush lantern ring which takes up the space of two packing rings. It should be positioned so as to meet the flushing hole on the gland.

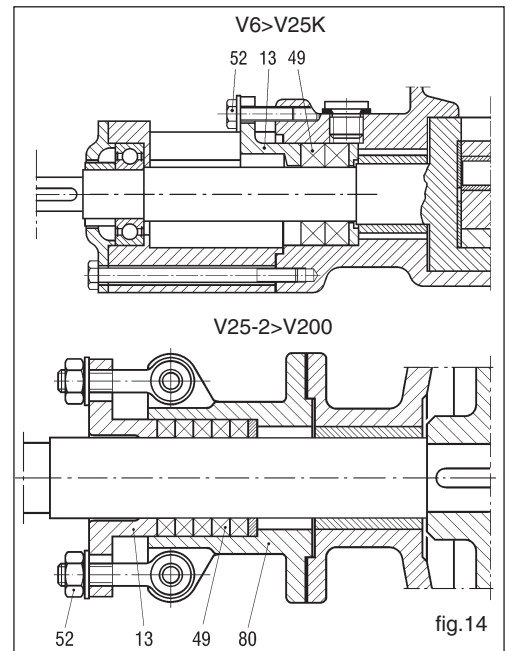

#### 11.8 Removing the ST5, ST6 mechanical seal (cast iron pumps from V6 to V25) (see fig. 15)

- Unscrew the cover (80.6) and remove the seal box (80) with the stationary portion (66.2). The rotation portion of the seal (66.1) can thus be uncovered.
- To remove it, it is sufficient to slide it along the shaft, taking care not to damage the internal gasket.

**Note:** a mechanical seal consists of two flat radial seats, one of which (66.1) is mounted in such a way as to rotate with the shaft.

The second seat (66.2) is stationary and the sealing action is ensured by the contact created between the two seats.

- Check all the seal components. If there are clear signs of damage, replace the seal as described under section 13.

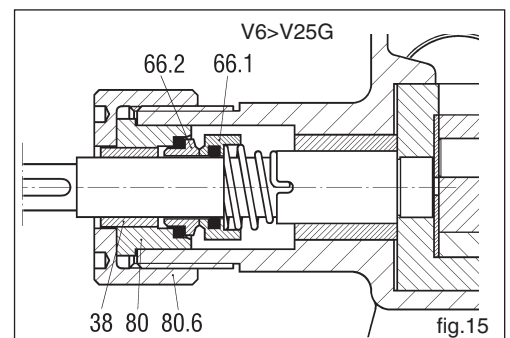

### 11.9 Removing the ST4, ST5, ST6 single mechanical seal (see fig. 16)

- ❑ Unscrew the screw (80.1) and move the seal box (80) carefully along the shaft, to avoid breaking the rear oil seal V ring (68). The rotation portion of the seal (66.7) can thus be uncovered.
- ❑ Loosen the grub screws and free the rotating seat of the seal. To remove it, it is sufficient to slide it along the shaft, taking care not to damage the internal gasket.

**Note:** a mechanical seal (66) consists of two flat radial seats, one of which (66.7) is mounted in such a way as to rotate with the shaft.

The second seat (66.2) is stationary and the sealing action is ensured by the contact created between the two seats.

- ❑ Check all the seal components. If there are clear signs of damage, replace the seal as described under section 13.

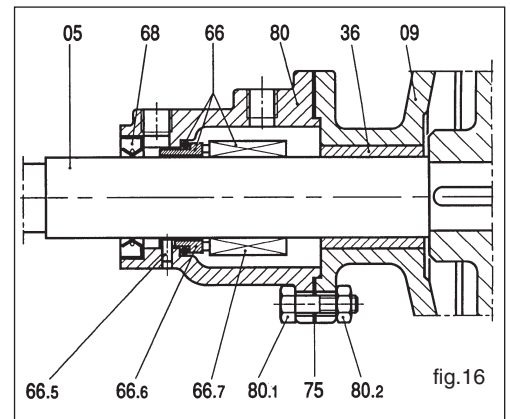

fig.16

### 11.10 Removing the ST7 double mechanical seal (see fig. 17)

- ❑ Unscrew the screws (80.1) and remove the seal box (81), taking care not to damage the gasket (75). If the gasket is damaged, it must be replaced.
- ❑ Loosen the grub screws of the rotating part of the mechanical seal (66.2) and remove it by sliding it carefully along the shaft, taking care not to damage the internal gasket.
- ❑ Repeat the operation with the second seal box (77) and the second mechanical seal (66.1).
- ❑ Check the state of the two mechanical seals and if there are any signs of damage, especially on the gaskets, replace them as described in paragraph 12.5.

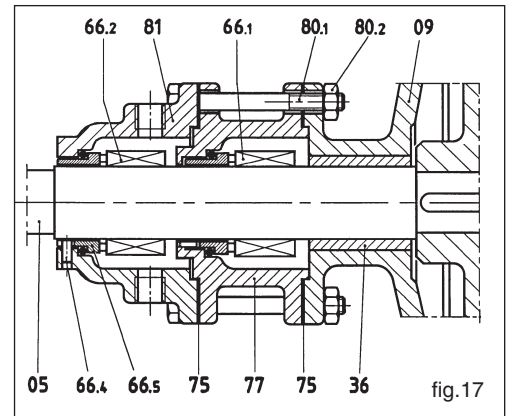

fig.17

### 11.11 Removing the ST8 double mechanical seal (see fig. 18)

- ❑ Unscrew the screw (80.1) and remove the rear seal box (81), taking care not to damage the gasket (75). If the gasket is damaged, it must be replaced.
- ❑ Loosen the grub screws of the rotating parts of the mechanical seals (66.1 and 66.2) and remove them by sliding them carefully along the shaft, taking care not to damage the internal gaskets.
- ❑ Check the state of the two mechanical seals and if there are any signs of damage, especially on the gaskets, replace them as described in paragraph 12.6.

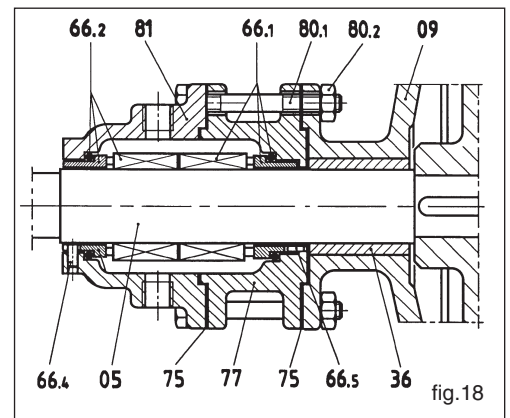

fig.18

### 11.12 Removing the shaft bush

- ❑ Dismount the pump completely as indicated for removing the rotor. Use a press to force the shaft bush out of the rear cover or pedestal if it is worn. Mount the new shaft bush in the same way.
- ❑ For the V 200, heat the rear cover to 80 deg C and insert the bush. Wait for it to cool. Use a lathe to bring the hole up to tolerance as instructed by the manufacturers.

### 11.13 Removing and disassembling the by-pass relief valve (see fig. 19)

- ❑ Remove the entire relief valve assembly, unscrewing the screws (46), taking care not to damage the gasket or gaskets (32). If these are damaged, they must be replaced.
- ❑ Remove the cap (26), the gasket (35) and loosen the lock nut (25) if fitted.
- ❑ Remove the cover (19), taking care not to damage the gasket (34). If the gasket is damaged, replace it.
- ❑ Remove the valve washer (22), the spring (23) and the valve poppet (20).
- ❑ Check the state of wear of the poppet and of its seat on the by-pass casing (18) and replace if necessary.
- ❑ Check the state of wear of the poppet and of its seat on the by-pass casing (18) and replace if necessary.
- ❑ Check the spring and washer and replace if necessary.
- ❑ Assemble the valve by proceeding in reverse order.

**Note:** For the pressure setting, see paragraph 10.5. We recommend setting the valve at 1 bar more than the delivery pressure.

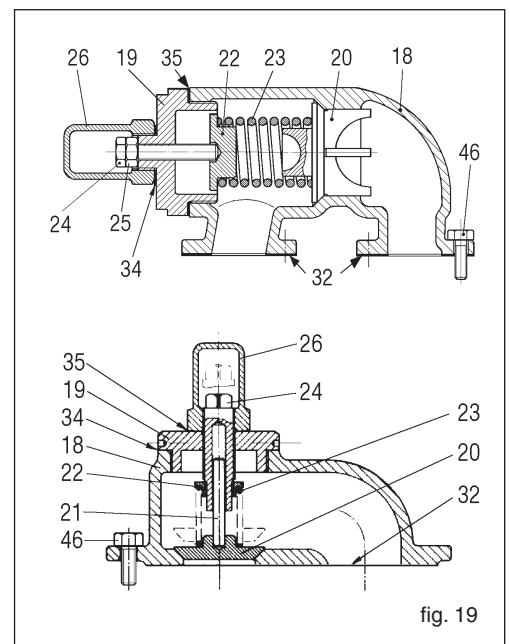

fig. 19

## 12 ASSEMBLY

In general, the disassembly instructions should be followed in reverse order.

### 12.1 Mounting the ball bearing (38)

- Clean the seat on the pedestal (08) thoroughly.
- Mount the bearing using a bench press.
- Tighten the bearing lock rings (14,15). They should be adjusted when the pump is completely assembled.

### 12.2 Mounting the shaft bush (36)

- Clean the seat in the rear cover (09) thoroughly. Press the bush into place using the press with a continuous movement. Ensure that the bush is not damaged.

### 12.3 Mounting the shaft and rotor (02)

- Mount the rotor key (41) in its seat on the shaft and force the shaft into the rotor with a press. Do not mount the shaft key (42).
- Assemble the shaft with the rear cover, pedestal and gland or seal box. This operation is easier to carry out with the pump positioned vertically resting on the rotor.

### 12.4 Mounting the ST5, ST6 mechanical seal (cast iron pumps from V6 to V25) (fig.20)

- Set up the shaft in the vertical position with the rotor on the bench.
- Clean the shaft thoroughly.
- Slip on the rotating part of mechanical seal (66.1) with the seat facing away from the rotor.  
Take care not to damage the internal gasket during this operation.
- Make sure that the spring is locked in its seat.
- Slip on seal box (80) with the stationary face (66.2) already fitted.
- Screw on the cover (80.6) until it is tight.

### 12.5 Mounting the ST4, ST5, ST6 mechanical seal (fig.21)

- Set up the shaft in the vertical position with the rotor on the bench.
- Slip on the rear cover (09).
- Clean the shaft thoroughly.
- Slip on the rotating part of mechanical seal (66.1) with the seat facing away from the rotor. Take care not to damage the internal gasket during this operation. Lock the grub screws after positioning the seal as shown in the table below.

**NB: The table shows the diameter D of the shaft and the distance L between the seal (66) and the rear cover (09) when the latter is not fixed in place but only resting on the rear of the rotor (fig. 22).**

- Mount the stationary seat (66.2) carefully in the seal box (80).
- Mount the V ring (68) in the seal box (80).
- Mount the seal box on the shaft without fixing it, taking care not to damage the V-ring.
- Slide the inner bearing lock ring (15) and the sleeve (17) on to the shaft
- Mount the pedestal and fix the rear cover temporarily to the pedestal. Screw on the shaft lock nut with its lock washer.
- Mount the outer bearing lock ring (14) and tighten the seal box screws.
- Mount the casing and cover and adjust the rotor position as described in paragraph 10.4.

**Attention:** The cover (04) must be mounted correctly. The idler pin (06) must be positioned symmetrically between the two ports in the shorter path between the ports.

- Block the security dowels (45) of the lock rings (14,15) ( models V25-2 and V30-2 do not have security dowels).

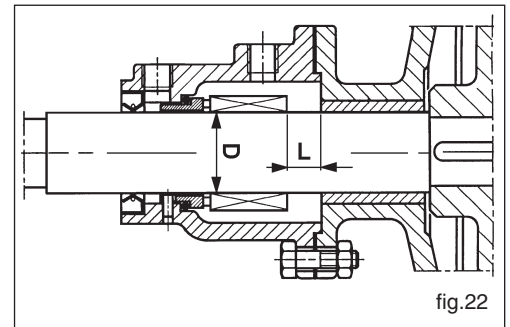
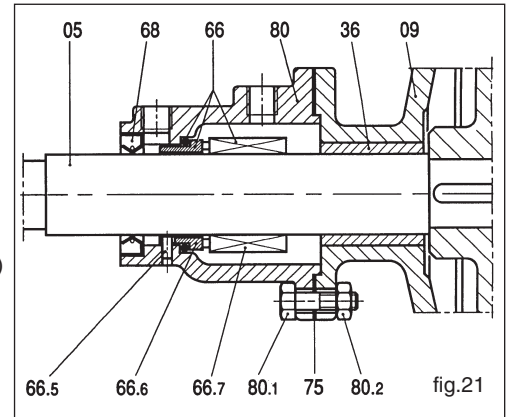
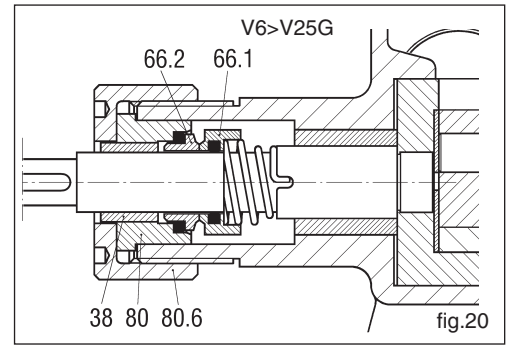

Dimension L for standard seals ISO 3069 DIN 24960 for pumps serie K

Pump type	D (mm)	L (mm)
V6, V12 *	14	-
V20, V25 *	18	-
V25-2, V30-2	22	9
V50-3	30	14
V60-2	35	18
V60-2 (+R)	35	17
V70-2	40	25,5
V70-2 (+R)	40	35,5
V80-2	40	25,5
V80-2 (+R)	40	35,5
V85-2	40	25,5
V90-2	55	22,5
V90-2 (+R)	55	34
V100-2	55	22,5
V100-2 (+R)	55	34
V120-2	70	9,5
V150-2	70	9,5
V151	70	9,5
V180	80	40,5
V200	90	35,5

ISO 3069 DIN 24960 standard seals

\* NON standard seals



### 12.6 Mounting the ST7 double mechanical seal (fig. 23)

- Set up the shaft in the vertical position with the rotor on the bench.
- Slip on the rear cover (09).
- Clean the shaft thoroughly.
- Slip on the rotating part of the mechanical seal (66.1) with the seat facing away from the rotor. Take care not to damage the internal gasket during this operation.
- Lock the grub screws after positioning the seal as shown in the table below.

**NB: The table shows the diameter D of the shaft and the distance L1 between the seal (66.1) and the rear cover (09) when the latter is not fixed in place but only resting on the rear of the rotor (fig. 24).**

- Mount the stationary seat carefully in the seal box (77).
- Mount the seal box on the rear cover and repeat the preceding operations with the second seal (66.2) and seal box (81).
- Mount the pedestal and fix the rear cover temporarily to the pedestal. Screw on the shaft lock nut with its lock washer.
- Mount the outer bearing lock ring (14) and tighten the seal box screws.
- Mount the casing and cover and adjust the rotor position as described in paragraph 10.4.

**Attention:** The cover (04) must be mounted correctly. The idler pin (06) must be positioned symmetrically between the two ports in the shorter path between the ports.

- Block the security dowels (45) of the lock rings (14,15) ( models V25-2 and V30-2 do not have security dowels).

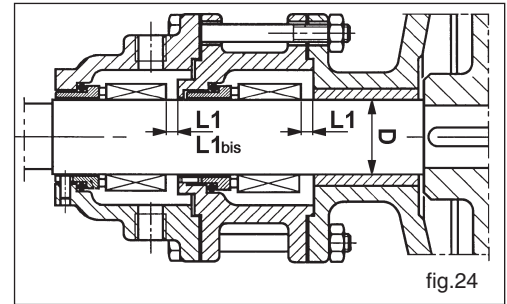
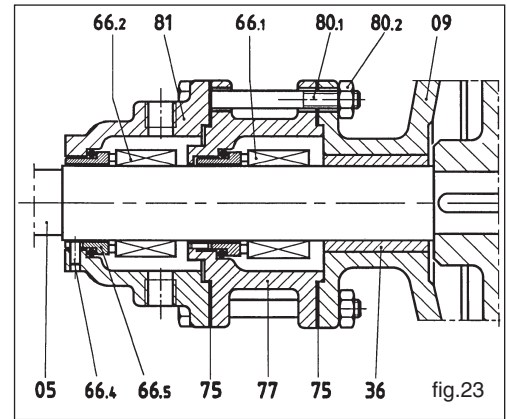

Dimension L1 for standard seals ISO 3069 DIN 24960 for pumps serie K

Pump type	D (mm)	L1 (mm)	L1bis (mm)
V25-2	22	-	-
V30-2	22	-	-
V50-3	30	6	-
V60-2	35	4,5	-
V70-2	40	15,5	-
V80-2	40	15,5	-
V85-2	40	15,5	-
V90-2	55	8	-
V100-2	55	8	-
V120-2	70	9,5	-
V150-2	70	9,5	-
V151	70	9,5	-
V180	80	24	-
V200	90	19	25

### 12.7 Mounting the ST8 double mechanical seal (fig. 25)

- Set up the shaft in the vertical position with the rotor on the bench.
- Slip on the rear cover (09).
- Clean the shaft thoroughly.
- Mount the seal box (77) after fitting the stationary seal seat (66.1).
- Mount the rotating part of the seal, ensuring that the two seats touch.
- Lock the grub screws after positioning the seal as shown in the table below.

**NB: The table shows the diameter D of the shaft and the distance L2 between the seal (66.1) and the seal box (77) when the rear cover (09) is not fixed in place but only resting on the rear of the rotor (fig.26).**

For the V25-2, is not necessary to fix the grub screws because the seal is double with a single rotating part. It is therefore sufficient to finish mounting the seal and, once the seal boxes are mounted, make the grub screws coincide with one of the two flush holes on the rear seal box and fix them.

- Mount the rotating part of the seal (66.2) with the seat facing upwards and fix the grub screws.
- Mount the seal box (81) after fitting the stationary seal seat (66.2).
- Mount the pedestal and fix the rear cover temporarily to the pedestal. Screw on the shaft lock nut with its lock washer.
- Mount the outer bearing lock ring (14) and tighten the seal box screws.
- Mount the casing and cover and adjust the rotor position as described in paragraph 10.4.

**Attention:** The cover (04) must be mounted correctly. The idler pin (06) must be positioned symmetrically between the two ports in the shorter path between the ports.

- Block the security dowels (45) of the lock rings (14,15) ( models V25-2 and V30-2 do not have security dowels).

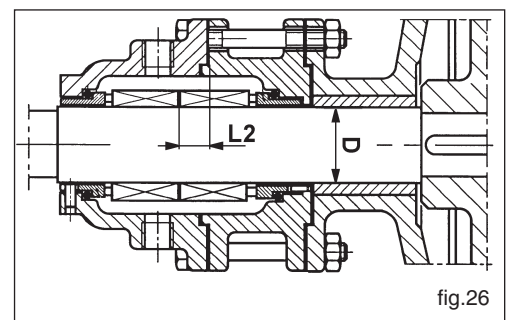
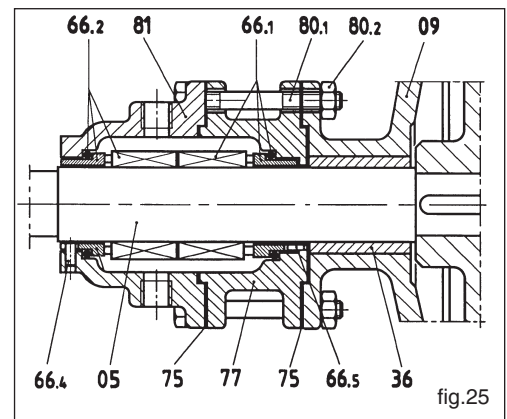

Dimension L2 for standard seals ISO 3069 DIN 24960 for pumps serie K

Pump type	D (mm)	L2 (mm)
V25-2	22	-
V30-2	22	-
V50-3	30	16,5
V60-2	35	15
V70-2	40	22,5
V80-2	40	22,5
V85-2	40	22,5
V90-2	55	27,5
V100-2	55	27,5
V120-2	70	14,5
V150-2	70	14,5
V151	70	14,5
V180	80	45,5
V200	90	40,5



### **12.8 Mounting the bushes**

The idler and shaft bushes be mounted using a press. They are perfectly symmetrical and can therefore be mounted in either direction. When mounting the bushes in their seats, use a continuous movement. For the V 180 and V 200, heat the idler and rear cover to 80 degrees C before mounting the bushes. Wait until they have cooled completely and use machine tools to bring them to the tolerance indicated by Varisco.

### **13 STORAGE**

If the pump is to be stored for a certain period of time, it is advisable to empty and clean it. If necessary, wash with a suitable solvent. Avoid using water.

Pour a little oil, fuel oil, or rust preventer into the pump, grease the bearing and turn the pump over a few times. If the pump is to be left out in the open, close the ports and cover the pump with a waterproof canvas. Take care to leave holes for ventilation to avoid condensation.

### **14 SPARE PARTS**

To order spare parts, specify the following:

- type of pump
- serial number of the pump
- reference number and description of the part as shown in the exploded drawing

### **15 DISPOSAL**

- Do not abandon in the environment
- Metal parts can be recycled as scrap
- Grease and oil must be recovered and stored as prescribed by the relevant legislation for disposal by approved agencies
- Elastomer gaskets must be removed and disposed of in an approved waste disposal unit



**VARISCO POMPE S.r.l.**

Zona Industriale Nord - Terza Strada, 9 - 35129 PADOVA - Italy

Tel. +39 049 82 94 312 - Fax +39 049 80 76 762 - e-mail: [export@variscopompe.com](mailto:export@variscopompe.com)

Web site : [www.variscopompe.com](http://www.variscopompe.com)