

YAMADA

INSTRUCTION

OIL PUMP

SH-110A5	MODEL No.851753
DR-110A5	MODEL No.851754
PD-110A5	MODEL No.851755

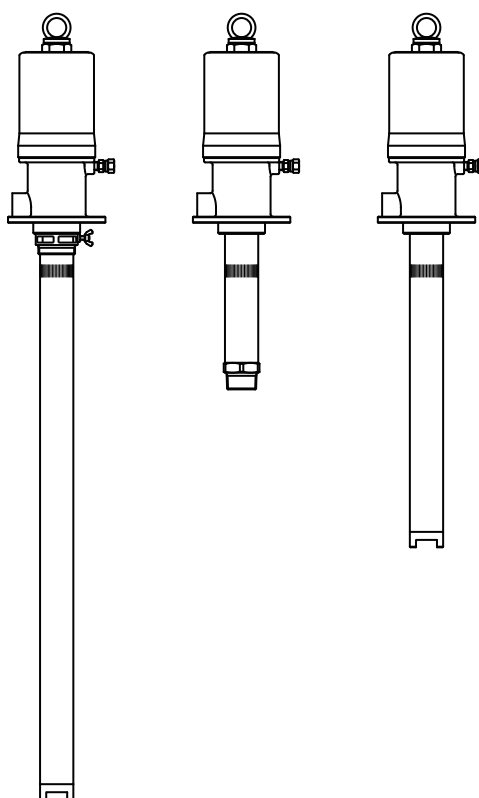

⚠ WARNING

Prior to operating this pump, be sure to read this operation manual for safety. After reading the manual, please keep it at hand any time for your quick reference.

YAMADA CORPORATION

- Preface

Thank you very much for purchasing Yamada Pump. The 110 type oil pump is dedicated to the oil that is liquid at the normal temperature and has a flash point of 200°C or more. This is an air-driven pump that is used to feed the oil in a drum can by pressure, draw out and divide oil into vessels, or inject a fixed quantity of oil.

- For Safe Operation

This manual describes the items that are important for the user to operate this product safely, correctly, and efficiently. Before operating this product, read this manual thoroughly, in particular, “Warnings and Cautions” at the beginning of this manual.

- Warnings and Cautions

For safe use of this product, be sure to note the following: In this document, warnings and cautions are indicated by symbols. These symbols are for those who will operate this product and for those who will be nearby, for safe operation and for prevention of personal injury and property damage. The following warning and caution symbols have the meanings described below. Be sure to remember their meanings.



WARNING: This indicates the existence of potential hazard which, if not avoided, will result in death or serious injury.



CAUTION : This indicates the existence of potential hazard which, if not avoided, may result in bodily injury or in physical damage.

Furthermore, to indicate the type of danger and damage, the following symbols are also used along with those mentioned above:



This symbol indicates an act that is prohibited (prohibition). The concrete contents of prohibition are indicated by the side of the indication.



This symbol indicates the contents that must be observed. The concrete contents of observance are indicated by the side of the indication.

- Precautions on Use

The following warnings and cautions are very important. Be sure to observe them.

WARNING

-  - Keep your face away from the exhaust and discharge ports. Material may suddenly come out. There is a possibility of losing eyesight if it strikes eyes.
-  - Gasoline is a high volatile fuel. Do not use it to clean the pump in any case, otherwise ignition or explosion may be caused.
-  - Keep your fingers away from each port to avoid injury from moving parts.
-  - Modification of this pump may lead to death, bodily injury, or a failure. Do not modify it in any case because it involves a risk.
-  - The operator and maintenance engineer should read the operation manual thoroughly before operating the pump and performing maintenance in respect of this pump.
-  - Always wear proper safety equipments(facemask, ear plugs, and safety shoes, etc.) when installing, operating and disassembling the pump.
-  - Make ground connection when working with flammable material or in explosive atmosphere. Rapid pumping of material can result in static electrical charge. Also, be sure to provide proper ventilation where a flammable atmosphere may exist.
-  - Execute the daily checkup.
-  - Use this pump according to the product specification.
-  - Attach a valve(for stop in emergency) or regulator to the air supply pipe to keep supply air pressure under 0.7 MPa.
-  - Discontinue it when you feel a hazard or abnormality during the work. And correspond according to the troubleshooting.
-  - Stop pump operation immediately when a drum becomes empty. Running the pump dry will cause excessive vibration, resulting in reduction of pump life and damage to other equipment. Be especially careful when pumping explosive material. Mixture of an air and vaporized material can explode. If there is any possibility of running dry, install a dry-run protection device like a liquid level control.
-  - Before maintenance operation, be sure to stop air from being supplied to the pump, and release the internal pressure (both air and material) of the pump. There is danger such as spouting of the material when the maintenance work is done with air supplied.
-  - Do not discharge material directly onto the ground. Dispose of harmful materials according to the requirements specified in MSDS or local regulations. Also, dispose of pump according to the local regulations after removing residual material from inside pump. (Please contact industrial waste disposal service.)
-  - (SH type only) If using a wall mount bracket for installation, the wall must be strong enough to withstand vibration of the pump.

CAUTION



- Keep hands and fingers away from the pump during operation to avoid injury from moving parts.



- Use pump for the material suitable for the specification. Parts may be corroded and material leak from the damaged parts can lead to environmental pollution. Also, follow handling notes (MSDS) of the manufacturer about the handling of the material used.



- Take fall-prevention measures if using a slim or light tank. Risk of falling will be increased due to shift in center of gravity caused by change in the material level in a tank.



- Take protective measures against rainwater and dust. It is likely to lead to the pollution of the material.



- Be very careful about the edge of the pump when you lift the pump. Your hands might be injured.



- Be very careful about your posture when installing the pump. Back injury may be caused by lifting the pump.



- Do not touch the surfaces of the pump and the hose when pumping high-temperature material. Risk of burns exists.



- Stop the air supply source after the end of work when not using this pump for a long time such as nighntimes and holidays. Also, open the valve of the exhalation port and liberate pressure in the pump and the hose. There is a possibility of polluting facilities because of the damage of the hose and the leakage of the valve. Such a secondary disaster becomes a responsibility on the user side.



- (DR type only) Place a drum on a flat, level surface to position pump horizontally against a ground. Operating the pump on a slope may cause a fall or tip-over due to shift in center of gravity caused by change in the material level.



- (DR type only) Material remaining inside or on the surface of the pump may spill out by inserting or removing the pump into/from a drum. Be very careful not to get your clothing dirty.

Table of Contents

- Preface	
- For Safe Operation	
- Warnings and Cautions	
- Precautions on Use	
1. Names and Materials of Parts	
1.1 Names and Materials of Parts	1
1.2 Contents of Package	1
2. Principles of Operation	2
3. Installation	
3.1 Installing the Drum Pump	2
3.2 Installing the Siphon Pump	3
3.3 Installing the Draw Change Material Hose	3
3.4 Installing the Pressure Feed Material Hose	4
3.5 Air Connection	4
4. How to Operate the Pump	5
5. Maintenance and Inspection	
5.1 Troubleshooting and Corrective Measures	6
5.2 Maintenance and Inspection	7
5.3 Consumable Parts	7
6. Pump Specifications	8
7. Accessory(851753 SH-110A5 type)	9
8. Limited Warranty	10

1. Names and Materials of Parts

1.1 Names and Materials of Parts

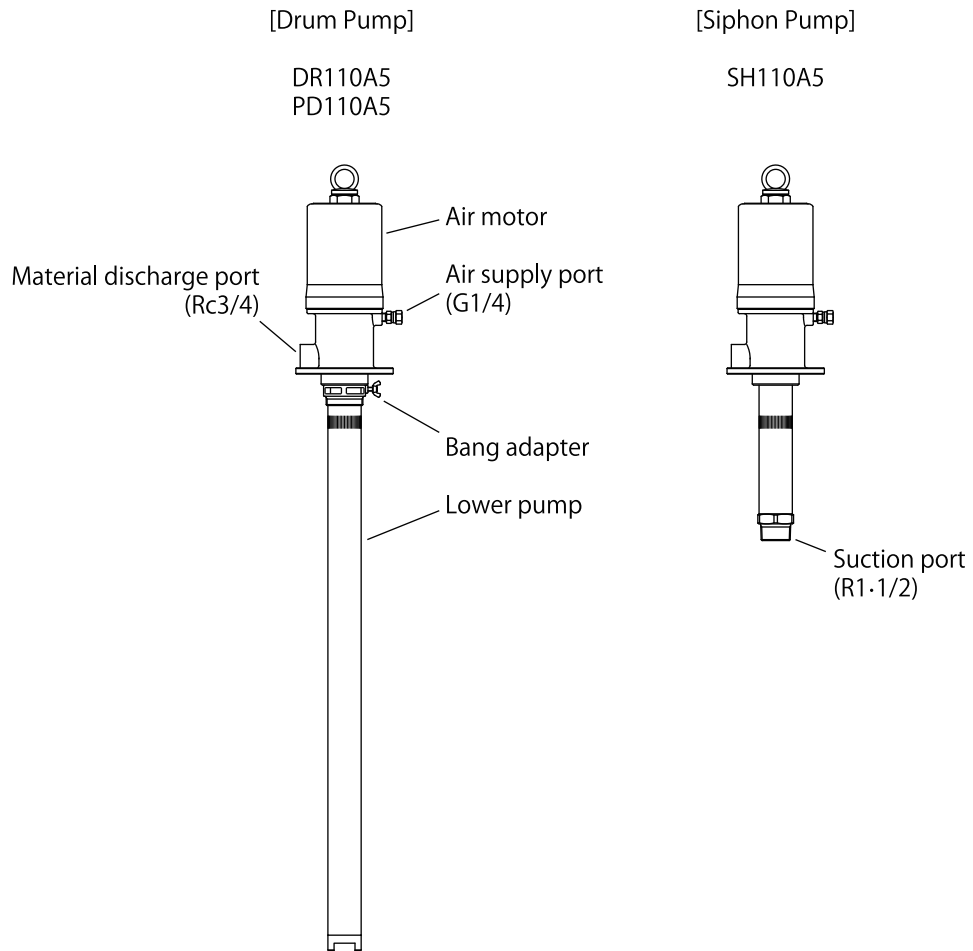

1.2 Contents of Package

This pump is packed in a corrugated fiberboard case. Open the corrugated fiberboard case and check if the product is not damaged.

2. Principles of Operation

The Yamada Air-powered Pump is a reciprocating type that is driven by compressed air. The pump consists of an air motor to drive the pump and a lower pump to draw up the material as shown in the figure at right.

When compressed air is supplied from the compressor to the air motor, the air piston starts its up/down motion by the function of the air switching mechanism built in it.

This motion is transmitted to the piston of the lower pump by the connecting rod that connects between the air piston of the air motor and the piston of the lower pump, thereby giving the up/down motion to it. When the up/down reciprocating motion of the piston of the lower pump is performed, the material is sucked into the lower pump and fed out from the discharge port by pressure.

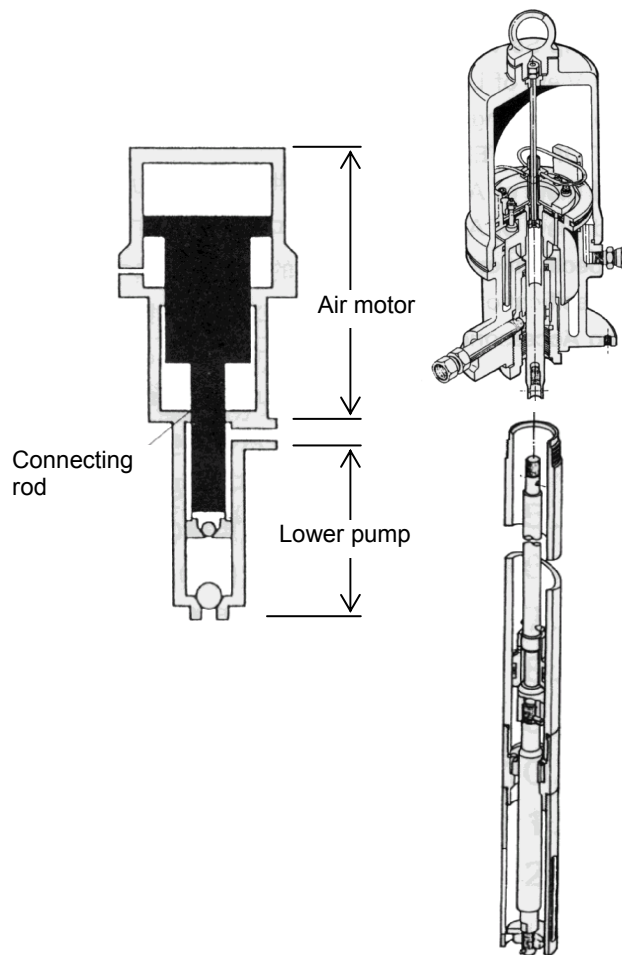

3. Installation

3.1 Installing the Drum Pump

- 1) Remove the plug at the injection port (2B) of the drum can and screw the bang adapter attached to the pump.
- 2) Insert the pump in the bang adapter. When the lower end (foot valve) of the pump touches the bottom of the drum can, lift the pump 2 or 3 cm to make a clearance between the foot valve of the pump and the bottom of the drum can, and fix the pump by tightening the thumb screw of the bang adapter. (Fig.1)

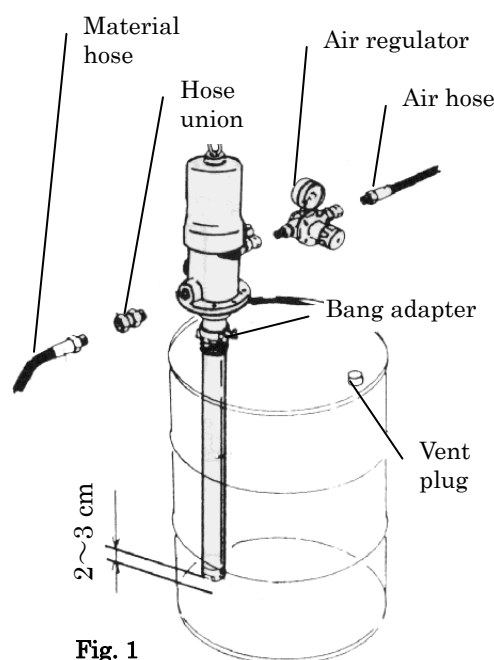

Fig. 1

⚠ WARNING



- When using a vessel with cover such as drum can, be sure to loose the vent plug so that the inside of the vessel may not form a vacuum.

3.2 Installing the Siphon Pump

When installing the pump at the panel unit (separately available) or the mounting bracket, observe the following procedure. (When purchasing the panel unit separately)

- 1) Loosen the bolt of the pump fixing band mounted on the mounting bracket and remove the band.
- 2) Putting the flange surface of the pump on the bracket, screw the support bolt with the pump fixing band and fix it.
- 3) Remove the plug at the injection port (2B) of the drum can and screw the bang adapter attached to the suction hose assembly (separately available).
Connect the pump to the suction hose assembly and insert the suction tube in the drum can. Make a clearance between the lower end of the tube and the bottom of the drum can and tighten the thumb screw of the bang adapter to fix the suction hose assembly. (Fig. 2)

[NOTE]

When installing the panel unit and the mounting bracket on the wall, select a place that permits secure fixing and can withstand vibrations. (Fig. 2 and 3)

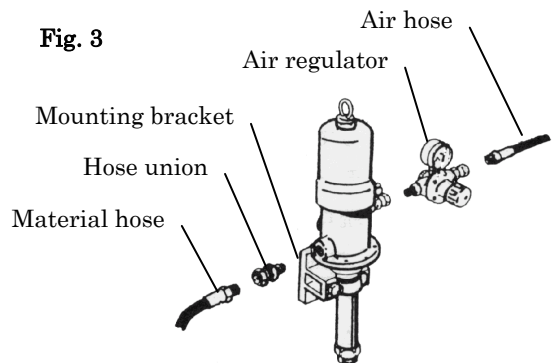
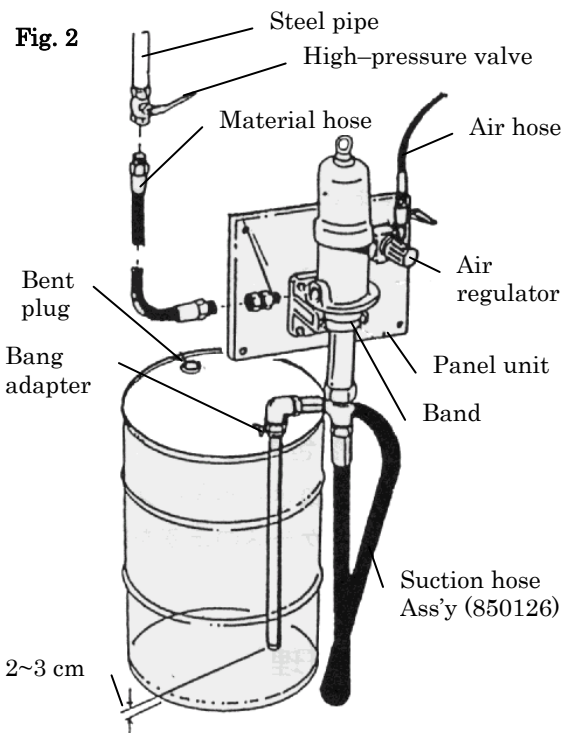

3.3 Installing the Draw Change Material Hose

- 1) Install the material hose (separately available) at the material discharge port (Rc3/4) of the pump. Tighten the union with a spanner so as not to make the material hose loose. In this case, wind the seal tape that is available on the market around the male screw of the hose and then screw it.
- 2) Install the gun fit for the application at the end of the hose.

3.4 Installing the Pressure Feed Material Hose

For pressure-feeding oil by piping at a long distance, observe the following procedure.

WARNING



- Do not connect the pump directly to the piping. Otherwise, when the pump is operated, the piping is damaged, the pump generates large noise, the pump does not permit changing the drum can, and the pump cannot be serviced. Be sure to connect a flexible hose between the pump and the piping.

- 1) Install the hose union and material hose (separately available) to the material discharge port (Rc3/4) of the pump. Tighten the hose union with a spanner so as not to make the material hose loose. In this case, wind the seal tape that is available on the market around the male screw of the hose and then screw it.
- 2) Install a valve between the end of the hose and the piping. (Fig. 4)
- 3) Be sure to install a relief valve so that leak may not be caused to the piping or damage may not be given to the hose connecting portion by the liquid pressure increased by temperature changes in the piping. The relief valve should be installed near the pump.

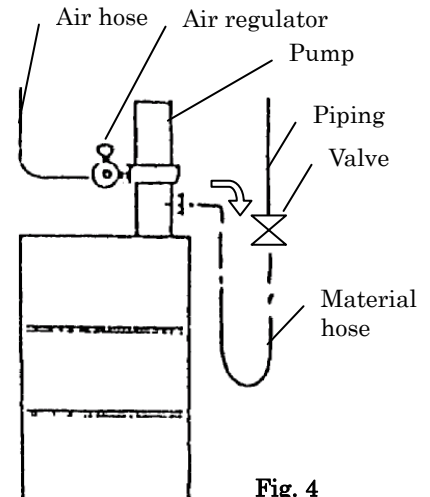

Fig. 4

3.5 Air Connection

- 1) Install the air regulator (separately available) at the air supply port of the pump. The dedicated air regulator is available as the standard product. Please use it.
- 2) Connect the air hose from the compressor to the IN side of the air regulator.

CAUTION



- Be sure to install the air regulator at the air supply port for the safe use of the pump. (The air regulator consists of a reducing valve and a pressure gauge.)

<NOTE>





- When air is supplied to the air hose, the pump is in operation. Before connecting the air hose, be sure to turn the knob of the air regulator counterclockwise to reset the pointer of the pressure gauge to "0".
- Using the air regulator permits adjusting the supply air pressure to the pump and reducing the wasteful motion of the pump, with the result that the operability is improved and the pump life is extended.

Regarding the method of adjusting the air pressure with the air regulator, the pressure is increased by turning the knob clockwise (the pointer of the pressure gauge gradually raises from "0") and reduced by turning it counterclockwise (the pointer of the pressure gauge goes back to "0").

In the normal operating status, the pointer of the pressure gauge should be at 0.3 to 0.5 MPa.

4. How to Operate the Pump

WARNING

-  - The supply air pressure to the pump should be 0.7 MPa or less. Do not raise the pressure over 0.7 MPa in any case.
-  - Never bring the face close to the exhaust port of the pump that is in operation. The material is discharged under high pressure, so water may congeal and injury may be caused by ice.
-  - If the air supplied to the pump is not shut off after completion of the work or at night, the hose may be damaged or leak may occur on the valve or gun, thereby causing a secondary accident. This secondary accident shall be attributable the user's responsibility.
-  - If the pump goes to a malfunction or into an operation stop status, do not disassemble the pump carelessly but refer to the item pertaining to <Troubleshooting and Corrective Measures> on P.4. Judge the status properly and do not disassemble any component other than the component that needs to be assembled.

<NOTE>

- After completion of the work or when the pump is not operated for a long time, shut off the air to stop the supply air to the pump and open the discharge port valve to reduce the internal pressure of the pump and hose.
 - If the oil in the drum can has be exhausted, the pump is operated at a higher speed without oil and has an adverse effect on its life. Stop the pump operation at once and replace the drum can with a new one. For replacing the drum can, observe the item pertaining to <Installing the Drum Pump> on P.2.
 - The distance for pressure feed differs depending on the viscosity, temperature, and required flow rate of oil. Regarding details, please ask Yamada Corporation or the dealer for further information.
- 1) Turn the knob of the air regulator clockwise to supply air into the pump. When the supply air pressure reaches 0.15 to 0.20 MPa, the pump starts to operate. The supply air pressure is indicated by the pointer of the pressure gauge.
 - 2) When air is supplied, the pump is operated for a while to fill the hose, pipe, and gun with grease, and then stopped automatically.
If the pump is continuously operated without stop, leak may have occurred in any connecting portion of the hose, pipe or gun. Stop the air supply and make a check.
 - 3) Oil is discharged by operating the gun lever at the end of the material hose. When the lever is pulled, the valve is opened and the pump is automatically operated to discharge oil.
When the lever is reset, the valve is closed to stop the oil discharge and the pump is also stopped.
 - 4) Adjust the supply air pressure according to the application. Usually, the operating pressure should be 0.3 to 0.5 MPa. In particular, when the pump is used for feeding oil, the discharge volume differs depending on the piping length and oil viscosity. Adjust the supply air pressure to your desired level.
 - 5) After completion of the work, be sure to stop the supply air to the pump.

5. Maintenance and Inspection

5.1 Troubleshooting and Corrective Measures

If the pump operation becomes unstable or trouble is caused to its grease discharge during operation, make a check according to the following procedure.

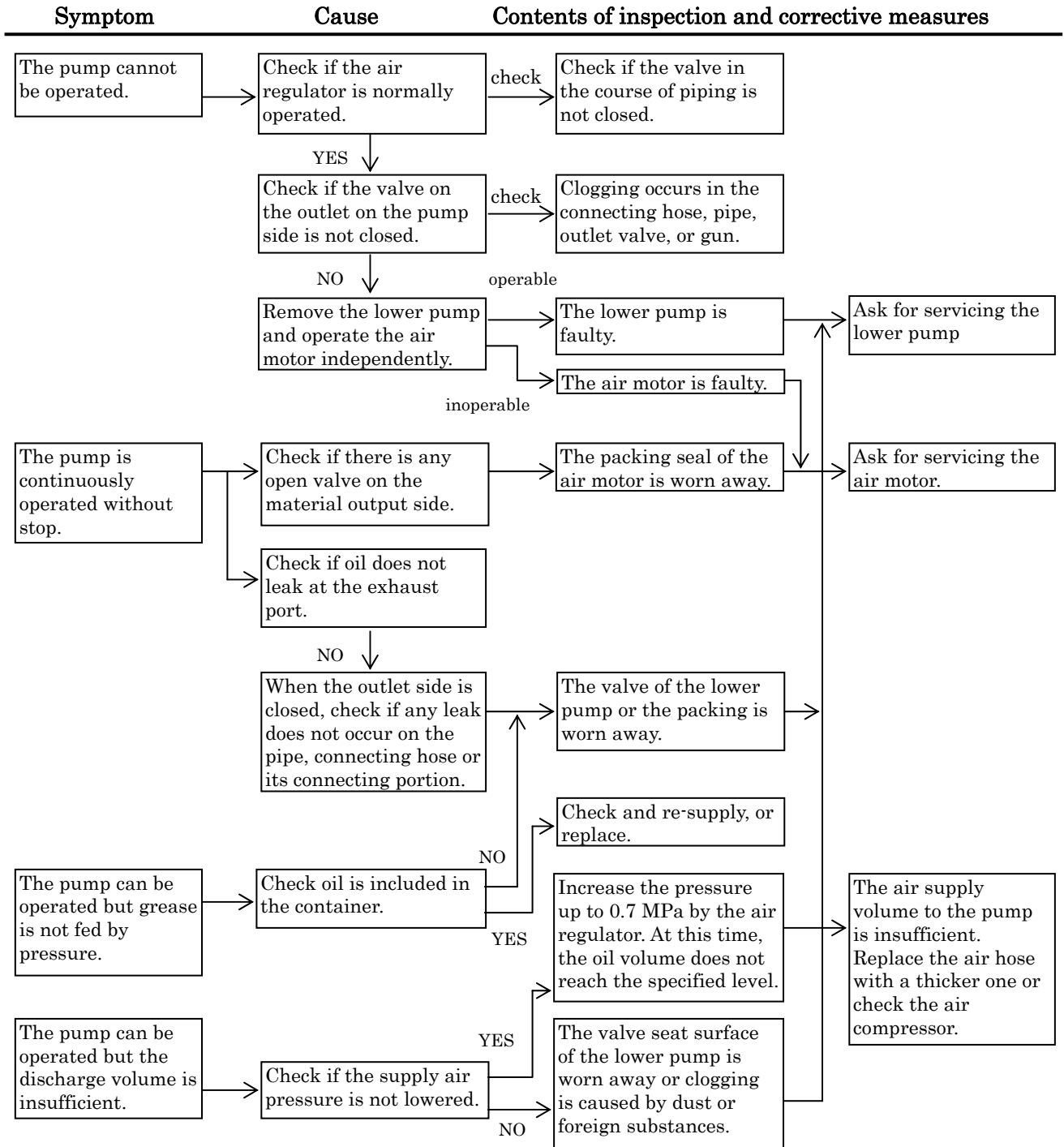

5.2 Maintenance and Inspection

For lubrication of the pump, perform oiling once every 10 days with lubricating oil.

Supply the lubricating oil as following.

- 1) Remove the air regulator.
- 2) Inject a few drops of lubricating oil (approx. 0.5 mL) into the air supply port as shown in the figure at right. Use turbine oil class 1 ISO (VG-32) or equivalent as the lubricating oil.

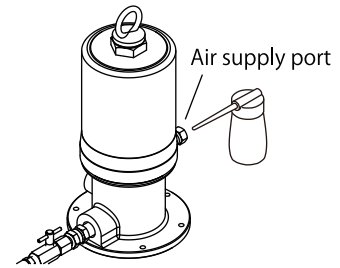

5.3 Consumable Parts

The hose is a consumable part. Check it periodically. If any flaw or leak is found, replace it a little early.

The parts used in the packing and slide portion of the pump will be worn away. They must be checked and replaced once a year.

6. Pump Specifications

■ Engineering Data

TYPE		DR-110A5	PD-110A5	SH-110A5
MODEL No.		851754	851755	851753
PUMP RATIO (NOMINAL)		5 x 1		
FLUID CONNECTION	SUCTION PORT	—		R 1-1/2
	DISCHARGE PORT	Rc 3/4		
AIR CONNECTION	SUPPLY PORT	G 1/4(F) (Union Adapter)		
OPERATING AIR PRESSURE		0.2 ~ 0.7 MPa		
MAXIMUM OPERATING NOISE	A-WEIGHTED SOUND PRESSURE LEVEL *1	81 dB		
	A-WEIGHTED SOUND POWER LEVEL *2	94 dB		
AMB. TEMP. RANGE	ENV. TEMPERATURE	0 ~ 60 °C		
	MATERIAL TEMP.	0 ~ 80 °C		
STROKE (NOMINAL)		60 mm		
DISCHARGE VOLUME per CYCLE *3		120 mL		
MAXIMUM DISCHARGE PRESSURE		3.5 MPa		
WEIGHT		12.0 kg	9.7 kg	8.3 kg

*1 Measurement method of A-weighted sound pressure level is based on ISO 1996.

*2 Measurement method of A-weighted sound power level is based on ISO 3744.

*3 Discharge volume (per cycle) varies according to use conditions.

■ Performance Curve

NOTE

The continuous pump operation should be avoided if the desired delivery is in the range shaded in the figure below.

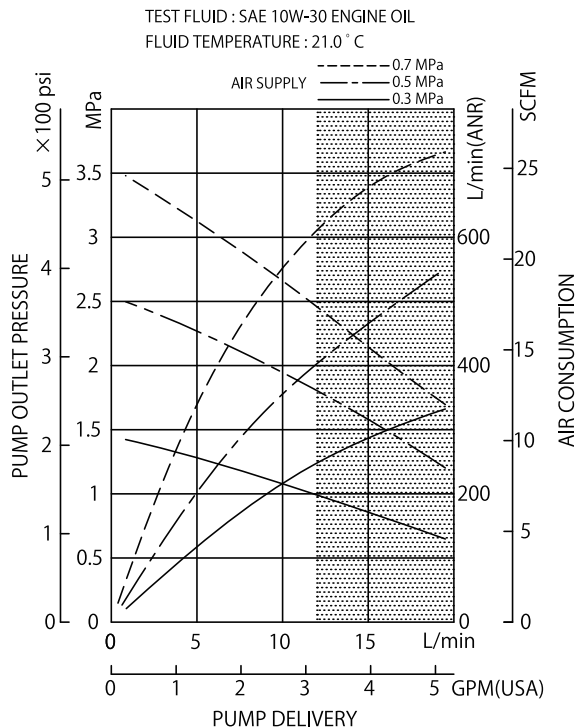

■ Dimensions

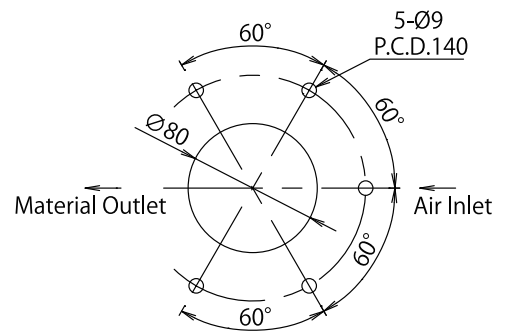

SH-110A5(851753) DR-110A5(851754)
PD-110A5(851755)

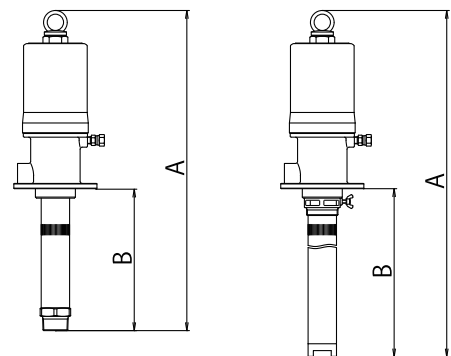

Model No.	A (mm)	B (mm)
851754	1275	935
851755	866	526
851753	610	270

7. Accessory(851753 SH-110A5 type)

851837 Panel Unit

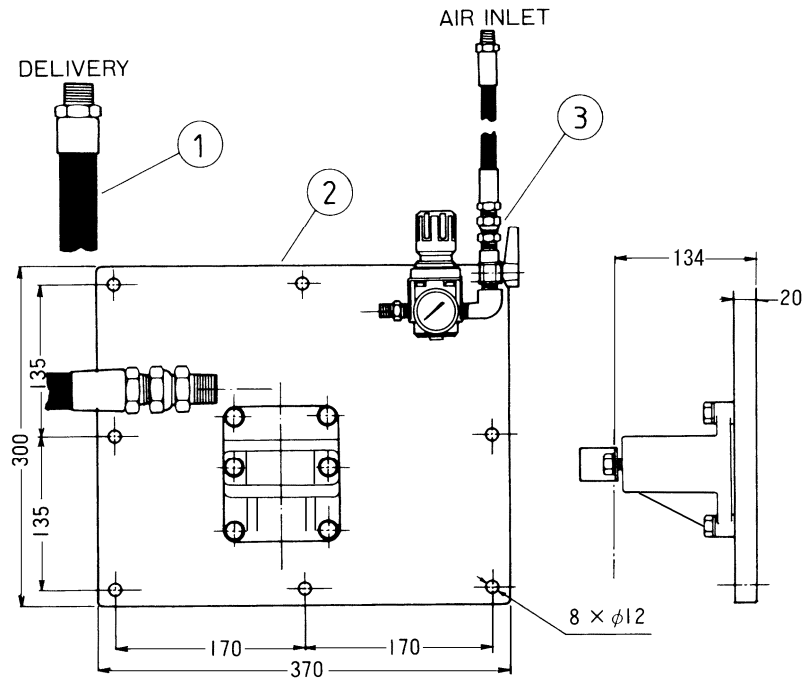

Ref. No.	Parts No.	Description	Q'ty
1	801102	Delivery hose assembly	1
2	802557	Panel assembly	1
3	802558	Air regulator assembly	1

850126 Suction Hose Assembly

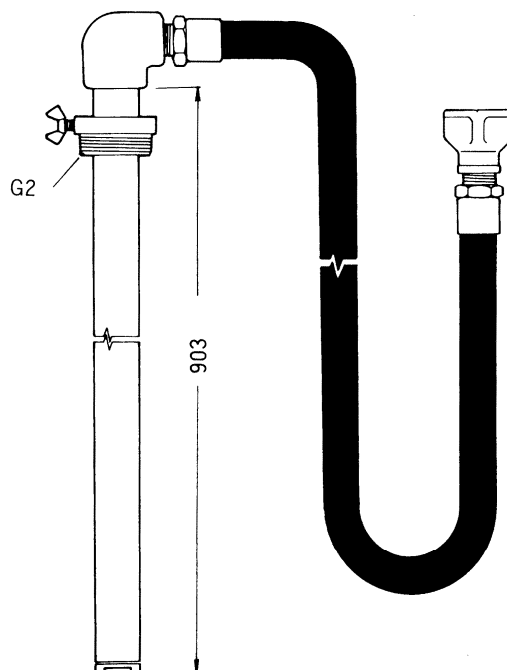

8. Limited Warranty

- If an abnormality occurs during normal operation in accordance with the operating instructions and other operating cautions within the warranty period (12 months after date of purchase) that can be attributed to a manufacturing defect, the defective parts of this product will be serviced or the product will be replaced free of charge. However, this warranty will not cover compensation for incidental damage or any malfunction listed below.

1. Warranty period

This warranty will be valid for a period of 12 months after the date of purchase.

2. Warranty

If, during the warranty period, any of the material of the genuine parts of this product or the workmanship of this product is found defective, and is so verified by our company, the servicing cost will be fully born by our company.

3. Exclusion

Even during the warranty period, this warranty does not cover the following:

- 1) Malfunction arising from use of parts other than manufacturer-specified genuine parts
- 2) Malfunction arising from misuse or operating errors, or lack of storage or maintenance care
- 3) Malfunction arising from use with a fluid that may cause corrosion, inflation or dissolution of the component parts of the product
- 4) Irregularity arising from repair made by other than by our firm, our regional office, dealer or authorized service personnel
- 5) Malfunction arising from modification of the product by other than authorized service personnel
- 6) Wear and tear of parts that must be regularly replaced in the course of normal operation, such as packings, O-rings, balls, and valve seats
- 7) Malfunction and/or damage due to transportation, moving or droppage of the product after purchase
- 8) Malfunction and/or damage due to fire, earthquake, flood or other force majeure
- 9) Malfunction arising from use of compressed air that contains impurities or excessive moisture, or use of gases or fluids other than the specified compressed air
- 10) Malfunction arising from use with a fluid that causes excessive abrasion or use of lubricating oil other than that specified for this product

Furthermore, this warranty does not cover the rubber parts, or other parts that are subject to wear in normal operation, used in this product and its accessories.

4. Parts

Parts for this product will be kept available for 5 years after discontinuation of production. Once 5 years have elapsed after close of production, availability of parts for this product cannot be guaranteed.

Manufactured by
YAMADA CORPORATION

INTERNATIONAL DEPARTMENT

No.1-3, 1-Chome, Mimami-Magome, Ohta-Ku, Tokyo, 143-8504, Japan

PHONE : +81-(0)3-3777-0241

FAX : +81-(0)3-3777-0584

YAMADA EUROPE B.V.

Aquamarijnstraat 50, 7554 NS Hengelo (0), The Netherlands

PHONE : 31(0) 74-2422032

FAX : 31(0) 74-2421055