

## OPERATION MANUAL

### GREASE LUBRICATOR

(for silicone grease)

TYPE : SKR-110M50SAL    MODEL No. 880677

---



#### WARNING

For safe operation, be sure to read this OPERATION MANUAL thoroughly before using the pump to understand the “Warnings and Cautions” particularly. Be sure to keep this OPERATION MANUAL handy for future reference.

# YAMADA CORPORATION

## –Introduction

This OPERATION MANUAL describes the correct operation procedures and contains notes on usage, so that you can operate this pump effectively without any problems. Do not operate this pump before reading this manual. Be sure to read all of the warnings and cautions. Keep this manual handy for future reference.

If you have any questions on the operation of this pump, or if the pump operates improperly, contact your dealer or our office (see back page of this manual for our contact information).

- ◇ If your manual is damaged or lost, additional copies may be purchased your dealer, or from Yamada directly.

## CONTENTS

Introduction.....	1
1. Purpose of Use.....	2
2. Warnings and Cautions .....	2
3. Operating Cautions .....	3
4. Name of Each Part.....	4
5. Preparations before Use .....	5
5.1 Assembling the machine.....	5
5.2 Setting a grease pail.....	5
5.3 Bleeding air from grease .....	7
6. How to Use.....	8
6.1 Operation for using a high-pressure grease gun.....	9
6.2 Replacing a grease pail .....	9
7. Maintenance and Inspection .....	10
7.1 Troubleshooting and Corrective measures .....	10
7.2 Maintenance and Inspection.....	11
7.3 Disassembly and Assembly .....	11
8. Exploded view and Parts list.....	13
9. Pump Specifications.....	15
10. Limited Warranty .....	16

## 1. Purpose of Use

This machine is a Type 110 air-powered pump mounted on a trolley equipped with an airlift, and pressure-feeds grease. It is best suited to fill products in the production line with grease as well as grease up vehicle and construction equipment and maintain various devices and facilities in all areas.

- You can use grease up to NLGI No.3 or equivalent with this machine under normal use conditions. If you use this machine at extremely cold or low temperature or if you use high viscosity of grease with this machine, the amount of grease to be discharged with the machine becomes extremely low.
- Silicon grease or material other than grease (such as putty and adhesive) cannot be used with this machine. If you want to use silicon grease, separately purchase a pump designed for silicon grease. If you want to remodel your pump so that it can handle silicon grease, contact your dealer.

## 2. Warnings and Cautions

For safe use of this product, be sure to note the following: In this document, warnings and cautions are indicated by symbols. These symbols are for those who will operate this product and for those who will be nearby, for safe operation and the prevention of personal injury and/or property damage. The following warning and caution symbols are described below.



### WARNING

If you ignore the warning described and operate the product in an improper manner, there is danger of serious bodily injury or death.



### CAUTION

If you ignore the caution described and operate the product in an improper manner, there is danger of personal injury or property damage.

Furthermore, to indicate the type of danger and damage, the following symbols are also used along with those mentioned above:





This symbol indicates a DON'T, and will be accompanied by an explanation on something you must not do.











This symbol indicates a DO, and will be accompanied by instructions on something you must do in a certain situation.

### 3. Operating Cautions

For safe use of the pump, be sure to follow the warnings and cautions described below.

 <b>WARNING</b>	
	- Some types of grease may contain a carcinogenic material. Read the cautions for handling grease given by the grease maker carefully when handling the grease.
	- Gasoline is a high-volatility material. Do not use gasoline to clean the pump in any case, otherwise it may cause ignition or explosion.

 <b>CAUTION</b>	
	- The maximum supply air pressure of this machine is 0.7 MPa. Using the machine with a supply air pressure exceeding this limit will lead to death or bodily injury or physical damage due to machine breakage. Be sure to adjust the supply air pressure below 0.7 MPa.
	- After the end of daily work, at night, and on holidays, be sure to shut off the supply air to this machine to release the gun so as to bleed the internal pressure. Any secondary accident such as pollution of installation, due to pump operation driven by worn-away packing or hose without shutting off the supply air, shall be attributable to the user's responsibility.
	- During machine operation or after completion of movement, be sure to lock the caster brake for locking.
	- Do not operate the gun lever with the discharge port facing to another person during machine operation in any case. A direct hit against the human body may result in an accident such as skin damage.
	- When replacing any part at maintenance, be sure to stop the air supply to the machine to avoid having fingers nipped because of a malfunction.
	- When you operate the lift up/down valve to attach a pail, do not touch the unit. If you happen to touch it with your hand, your hand may be caught between the pail and the machine and injured.
	- If any sand or dust is stuck to the pump suction section or inductor plate when you set or replace a pail, it may cause not only the pump but also your valuable greased machine or product to malfunction. Set or replace a pail with extreme care.

#### 4. Name of Each Part

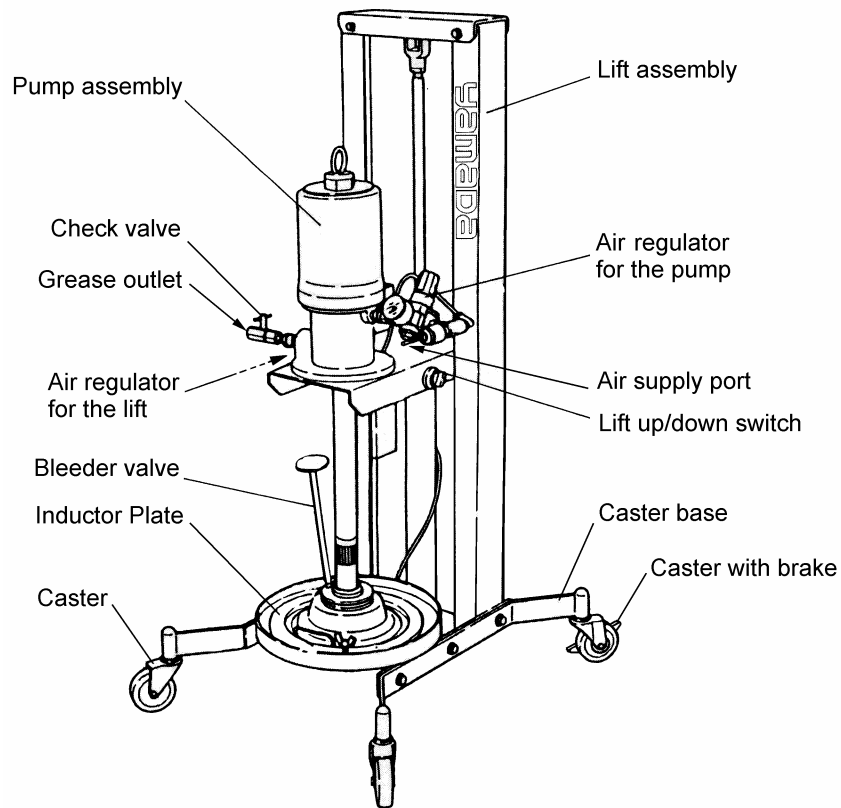

#### Contents of package

The main devices and the accessories are packed in different cases.

Open the top part of the corrugated fiberboard case and check if the devices is not damaged and if accessories are all contained in the package.

## 5. Preparations before Use

### 5-1. Assembling the machine

- 1) Casters of this machine are disassembled and packed, then delivered to your site. Use the supplied bolts, washers and spring washers to assemble the casters. (See Fig-1)
- 2) The rubber cap is put on the suction section of the pump (inside the inductor plate) for protection. (See Fig-1) Be sure to remove this rubber cap before using the machine.
- 3) Attach the supplied air regulator onto the union located at the air inlet of the pump.
- 4) Insert the air tube that supplies air pressure to the lift into the fitting of the air supply inlet.
- 5) Connect the high-pressure hose designed for grease to the grease discharge outlet (check valve section) of the pump. (See Fig-2)

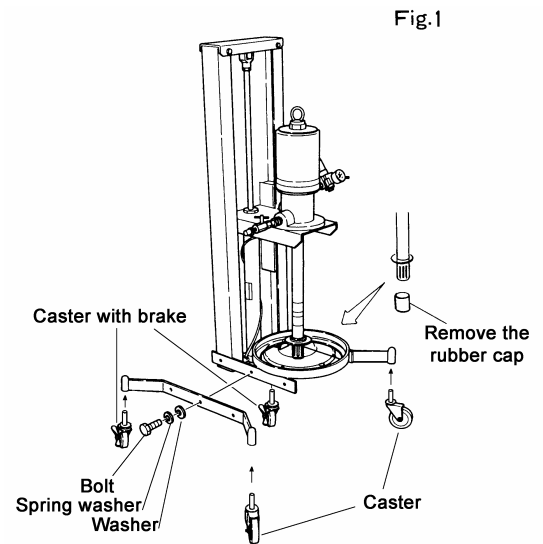

### NOTE

Any high-pressure hose designed for grease is not supplied with this machine. Separately purchase our genuine product and use it. A high-pressure grease gun or constant-rate valve can be attached onto the discharge outlet of the hose. Select and purchase the product appropriate for your application.

- 6) Attach the supplied air chuck onto the air hose connected to the compressor, and fix it with the hose band or similar device.

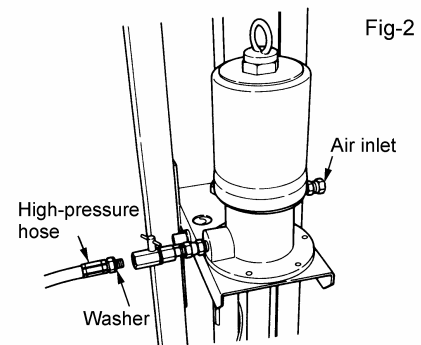

### 5-2. Setting a grease pail

- 1) Remove the bleeder plug from the inductor plate. (See Fig-3)
- 2) Turn both the control of the air regulator for the pump and that for the lift of the pump unit to the left (anticlockwise) to loosen them. (See Fig-3)

Set the control of the lift up/down switch to "Down."  
(See Fig-4.)

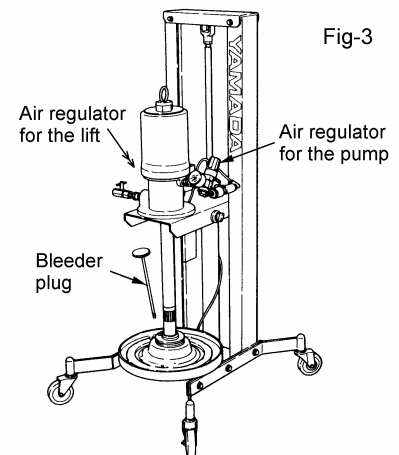

### NOTE

The air regulator allows you to adjust the pressure of air to be supplied to the pump, and it reduces the waste motions of the pump: it improves the operability of the pump and extends the life of the pump.

To adjust the air pressure with the air regulator, turn the control to the right. The air pressure increases (the pointer of the pressure gauge moves from "0" to the larger value). When you turn the control to the left, the air pressure decreases (the pointer of the pressure gauge returns to "0").

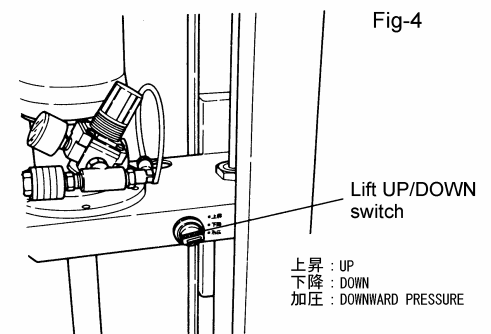

- 3) Connect the air hose prepared at Section 5-1 6) to the air supply inlet, and supply air to the machine. (See Fig-5)  
If the pump operates at this point, the air regulator for the pump is not returned to the original position completely. Turn it to the left further to loosen it.

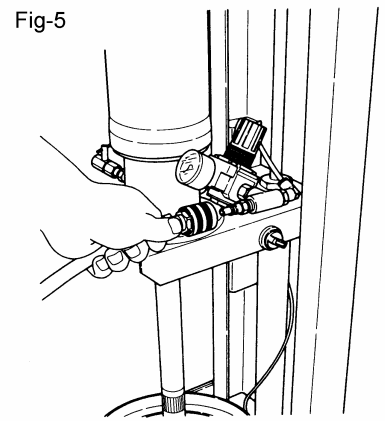

- 4) Gradually turn the control of the air regulator for the lift to the right (clockwise) to set the pointer of the pressure gauge so that it can indicate a value from 0.3 MPa to 0.4 MPa. (See Fig-6)

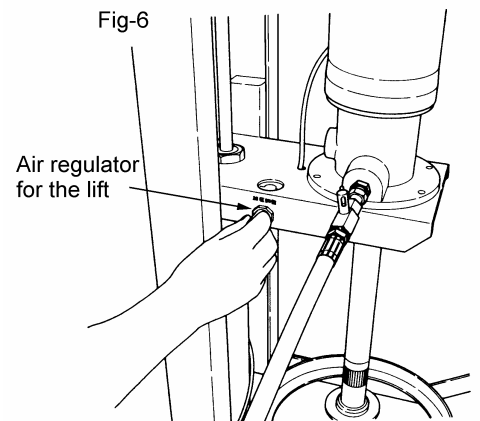

- 5) Switch the control of the lift up/down switch to “UP.” The lift moves upwards. (See Fig-7)  
If the lift does not move upwards, increase the supply pressure for the lift gradually.

When the lift moves upwards, it indicates that you have made the preparation for setting a grease pail.

- 6) Remove the lid of a new grease pail, and set the pail onto the base section of the pump unit properly.

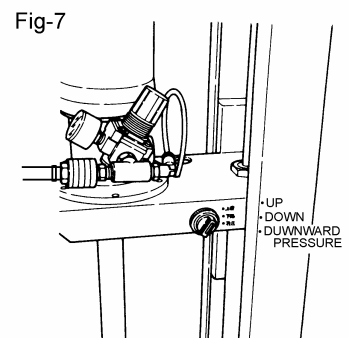

**NOTE**

If you do not set a pail properly, any grease is not discharged. Be sure to set it on the correct position.

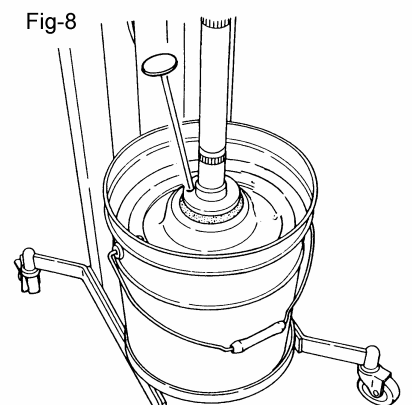

- 7) Switch the control of the lift up/down switch to “DOWN.” The lift slowly moves down due to the pump’s own weight. Adjust the position of the pail so that the inductor plate can be set normally. (See Fig-8)



	<b>CAUTION</b>
	- Do not put your hand or finger between a pail and the inductor plate. If either one is caught between them, it is injured. Handle them with extreme care.

- 8) Check to see if the inductor plate is set correctly, and then switch the control of the lift up/down switch to "UP." (See Fig-9)

When grease is pressurized with the inductor plate and pushed out from the hole of the bleeder plug, switch the control of the up/down switch to "DOWN." Then, temporarily stop pressurizing the grease, and attach the bleeder plug.

Fig-9

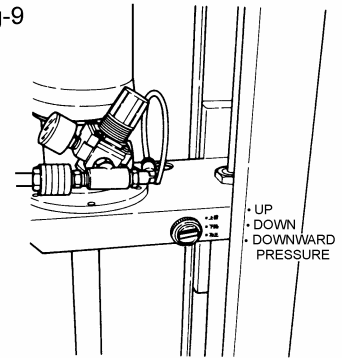

### 5-3. Bleeding air from grease

#### NOTES

- To operate the control of the air regulator, pull out the control, and then turn it. After setting the air pressure, push down the control. The control is locked.
  - Check to see if the valve of the discharge outlet is closed.
- 1) When you gradually turn the control of the air regulator for the pump to the right (clockwise), the pump starts operating when the air pressure reaches approximately 0.2 MPa to 0.3 MPa. The pump and hose are filled with grease, and the pump stops. (See Fig-10)
  - 2) Air is mixed into the grease at first, and grease is not in the good conditions. Open the check valve located at the outlet of the pump, and discharge the grease mixed with air from the small hole under the check valve completely. Note that you have to spread a piece of paper or other material on the floor around the pump so that you cannot happen to touch any grease, and discard the discharged grease. (See Fig-11)

Fig-10

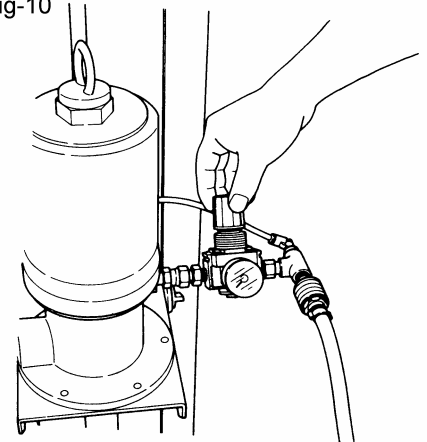

#### NOTE

Grease mixed with air is cloudy.

- 3) After bleeding air from grease, tighten the check valve securely.

Fig-11

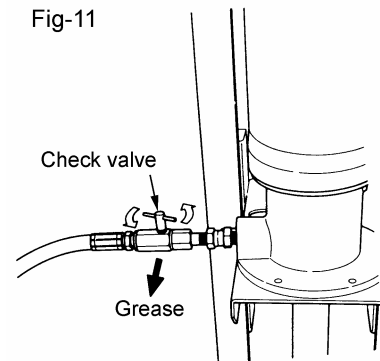







## 6. How to Use



### CAUTION

-  - The maximum supply air pressure of this machine is 0.7 MPa. Using the machine with a supply air pressure exceeding this limit will lead to death or bodily injury or physical damage due to machine breakage. Be sure to adjust the supply air pressure below 0.7 MPa.
-  - Do not operate the gun lever with the discharge port facing to another person during machine operation in any case. A direct hit against the human body may result in an accident such as skin damage.
-  - After the end of daily work, at night, and on holidays, be sure to shut off the supply air to this machine to release the gun so as to bleed the internal pressure. Any secondary accident such as pollution of installation, due to pump operation driven by worn-away packing or hose without shutting off the supply air, shall be attributable to the user's responsibility.
-  - During machine operation or after completion of movement, be sure to lock the caster brake for locking.

- 1) Adjust the air regulator for the lift to set the pointer of the pressure gauge so that it can indicate a value from 0.1 MPa to 0.5 MPa with following the description of "NOTE" below. (See Fig-12)

#### NOTE

When you increase the pressure of air supplied to the lift, the inductor plate presses grease more strongly. Grease overflows the gasket surrounding the inductor plate when the inductor plate presses grease too strongly although you have to strongly press solid grease or ordinary grease in an extremely cold place. Select the pressure best suited to grease to be used or your site while using the machine.

- 2) Adjust the air regulator for the pump to set the pressure supplied to the pump to 0.2 MPa to 0.5 MPa. (See Fig-13)
- 3) When you open the valve located at the end of the hose, grease is discharged and the pump automatically starts operating. Check to see if grease is discharged normally before using the machine.
- 4) When you close the valve, the machine stops discharging grease, and the pump automatically stops. Keep stopping the pump in this way during work. Just by opening the valve, the machine can discharge the necessary amount of grease any time.
- 5) After finishing your work, be sure to stop supplying air to the machine, and open the valve of the grease discharge outlet (a little amount of grease is discharged) to release the pressure from the hose and pump.
- 6) If the pump starts operating wildly during work, there may be no grease in the set pail or the pump may operate without discharging any grease due to an air pocket generated. Stop operating the pump immediately, and inspect it.

Fig-12

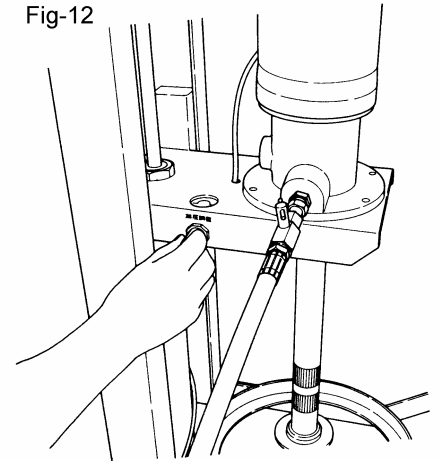
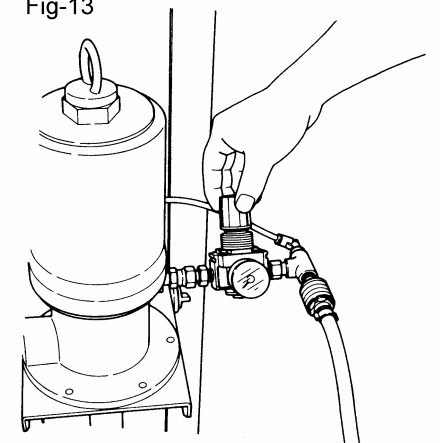

Fig-13



## 6-1. Operation for using a high-pressure grease gun

To supply grease to a grease nipple, you have to separately purchase a high-pressure grease gun (part number: 851985) for the outlet valve.

- 1) Follow the operation steps 1) and 2) of the section “How to Use” described above to set each regulator.
- 2) Wipe the grease nipple to be used for greasing cleanly. After that, push the chuck at the end of the grease gun against the nipple to perform chucking as vertically as possible. (See Fig-14)
- 3) Pull the gun lever to supply grease. When grease is normally injected, old grease will be squeezed out from the groove or clearance near the nipple.
- 4) After completion of grease supply, release the gun lever. The pump will be automatically stopped.
- 5) Remove the chuck at the end of the grease gun. Since pressure is applied to the chuck, the head of the nipple may be broken if it is suddenly pulled. Incline the chuck to bleed the internal pressure, and the chuck can be easily removed. (See Fig-15)
- 6) After completion of greasing work, be sure to shut off the supply air of the pump and bleed the internal air of the hose.
- 7) If the pump is suddenly started, it may be due to non-existence of grease in the pail can or an air pocket produced. Stop the greasing work and make a check.
- 8) Exchange the grease can when the grease stopped coming out.

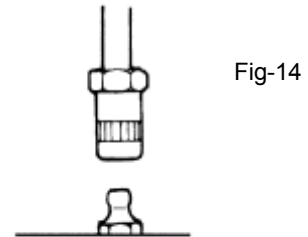

Fig-14



Fig-15

## 6-2. Replacing a grease pail

- 1) When the amount of the remaining grease in a pail draws to an end, the pump operates wildly without discharging any grease. Stop your work immediately, and turn the control of the air regulator for the pump to the left to return the pressure of the air supplied to the pump to “0.” The pump stops operating.
- 2) Loosen the bleeder plug to remove it.
- 3) When you switch the lift up/down valve to “UP,” the pump moves upwards, when the pail set on the machine moves upwards at the same time. Pry the pail away from the machine. (See Fig-16)

### NOTE

After removing the pail, remove the air chuck located at the air supply inlet for your safety, and stop supplying air to the unit.

- 4) Follow the section “Setting a grease pail” of “Preparations Before Use” on page 4 to set a new grease pail.
- 5) After replacing the grease pail with a new one, check to see if there is no air mixed into the grease before using the machine by following the section “Bleeding air from grease” of “Preparations Before Use” on page 6.

Fig-16

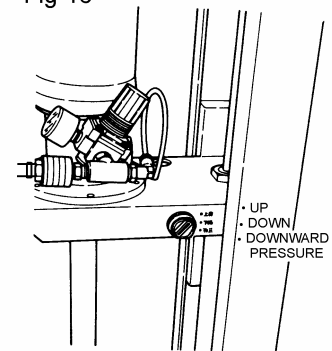

## 7. Maintenance and Inspection

### 7-1. Troubleshooting and Corrective measures

If the pump operation becomes unstable or trouble is caused to its grease discharge during operation, make a check according to the following procedure.

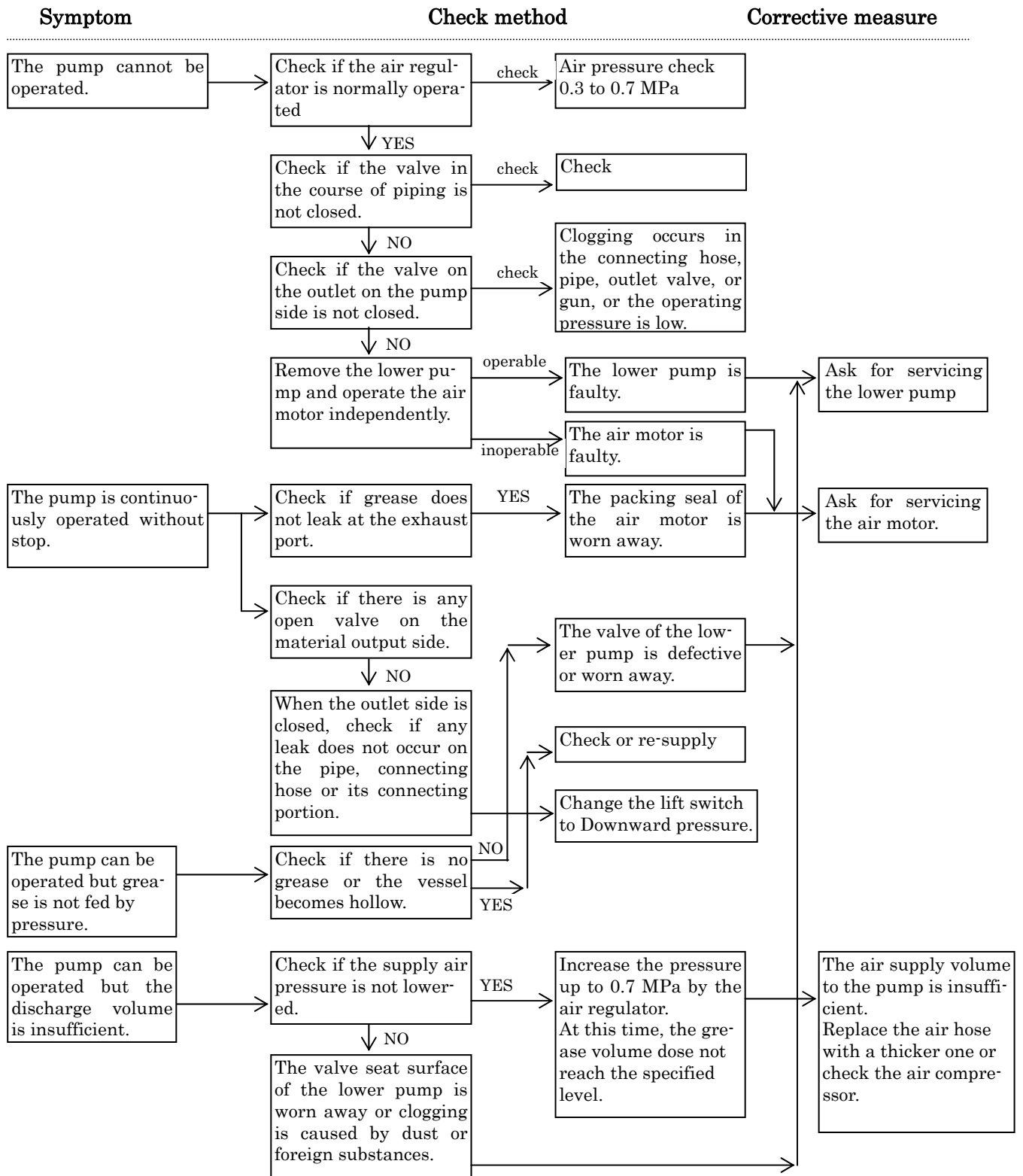

## 7-2. Maintenance and Inspection

### [Lubrication]

For lubrication of the pump, perform oiling once every 10 days with lubricating oil.

Supply the lubricating oil as following. (See Fig-17)

- 1) Remove the air regulator.
- 2) Inject a few drops of lubricating oil (approx. 0.5 ml) into the air supply port as shown in the figure at right.  
Use turbine oil class 1 ISO (VG-32) or equivalent as the lubricating oil.

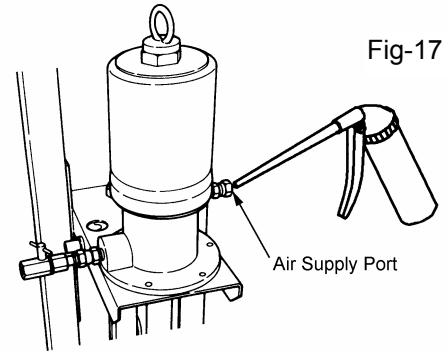

### [Inspection]

The hose is a consumable part. Check it periodically. If any blemish or leakage is found, replace the hose little earlier. The packing and slide portion parts of the pump are worn away. Check and replace them once a year.

## 7-3. Disassembly and Assembly

When the pump operation becomes defective or stops, do not disassemble the pump thoughtlessly but judge the condition carefully by referring to the item pertaining to <Troubleshooting and Corrective Measures>.

The air motor that is not brought into direct contact with the material becomes defective rarely, so it does not need to be disassembled. If disassembly is required, ask the dealer to disassemble the air pump.



### WARNING



- Gasoline is a high-volatility material. Do not use gasoline to clean the pump in any case, otherwise it may cause ignition or explosion.



- When disassembling and checking the pump, be sure to stop the supply air and open the outlet valve to release the internal pressure of the pump beforehand.



- When washing parts, do not use such a liquid as corrodes aluminum, copper alloy, iron, etc.

### Separating the air motor from the lower pump

- 1) Shut off the air that is supplied to the pump and bleed the internal pressure of the pump.
- 2) Remove the high-pressure hose and the air hose from the pump.
- 3) Remove the pump assembly from the lift.  
Unscrew the 5 bolts (on the rear side of the lift) that fix the pump assembly and the lift and separate the pump assembly from the lift.
- 4) Fix the air motor body of the pump on the vise and set a pipe wrench on the knurling section of the suction tube of the lower pump and unscrew it. (See Fig-18)

#### NOTE

The air cylinder is easily damaged. Do not fix it on the vise in any case.

- 5) Pull out the suction tube, and the connecting stud that connects the piston rod of the air motor becomes visible. Pull out the spring pin of the connecting section and unscrew the connecting stud or the lower pump, and the air motor can be separated from the lower pump.

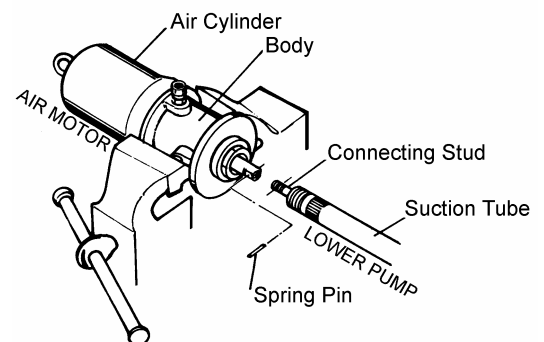

## Disassembling and inspecting the lower pump

- 1) Fix the suction tube on the vise and set a pipe wrench on the booster cover. Unscrew the suction tube and remove the spring pin, nut, and shovel. (See Fig-19)
- 2) Likewise, set a pipe wrench on the valve case and unscrew it. The valve stopper and the foot valve (a part of the plunger assembly) can be removed.
- 3) Pull out the plunger rod from the suction tube by holding it. The piston and connecting rod assembly can be pulled out. (See Fig-20)
- 4) Pull out the spring pin that connects between the connecting rod and the plunger, and take out the plunger.

Wash the plunger and check it for blemish and wear.

### [NOTE]

The plunger is an assembly for mating with the valve. Insert the foot valve in the plunger, and check if it can smoothly slide. These two parts, if they are blemished, must be replaced as an assembly.

- 5) The portions with which the lower part of the piston and the connecting stud come into contact form a seat surface. Check them for blemish.
- 6) Wash and check each disassembled part. If any blemish or wear is found, replace the part with a new one.
- 7) For assembling, reverse the disassembling procedure. (See Fig-21)

In particular, perform assembling taking care about the directions of the valve seat and the foot valve.

### NOTE: Disassembling the air motor

The air motor is not easily adjusted at assembly. If an air motor failure is found at maintenance and inspection, ask the dealer to repair the air motor.

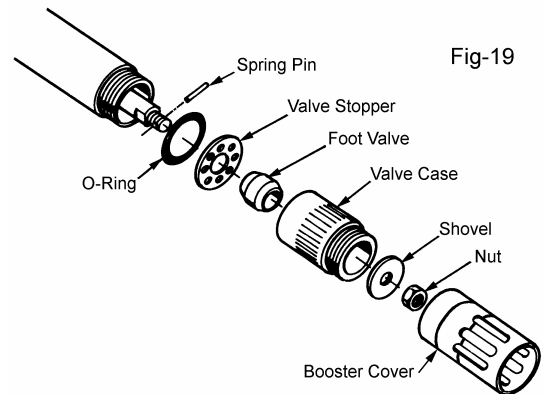

Fig-19

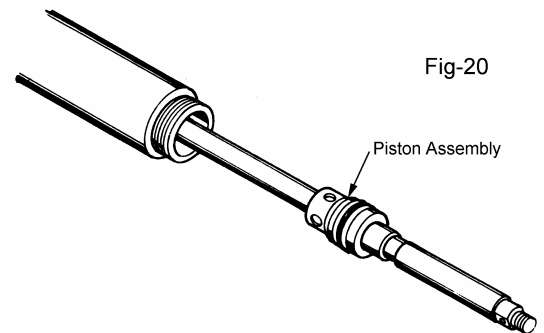

Fig-20

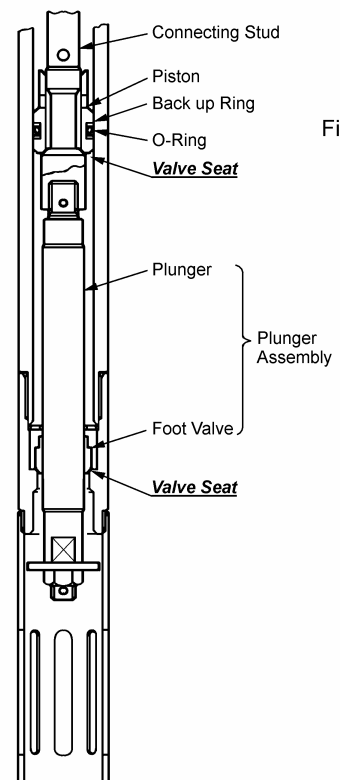
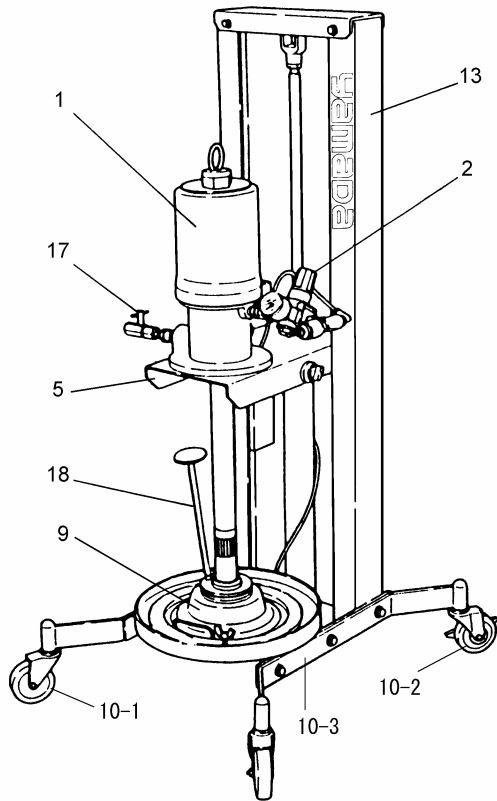

Fig-21

## 8. Exploded view and Parts list



### 880677 SKR110M50SAL

Item No.	Part No.	Description	Q'ty
1	851999	Pump Assembly	1
2	802502	Regulator Assembly	1
5	802470	Roller Assembly	1
9	802629	Inductor Assembly	1
10-1	681700	Caster	2
10-2	681696	Caster with Brake	2
10-3	831384	Caster Base Arm	2
13	831479	Lift Base Assembly	1
17	800431	Check Valve Assembly	1
18	831558	Air Releaser	1

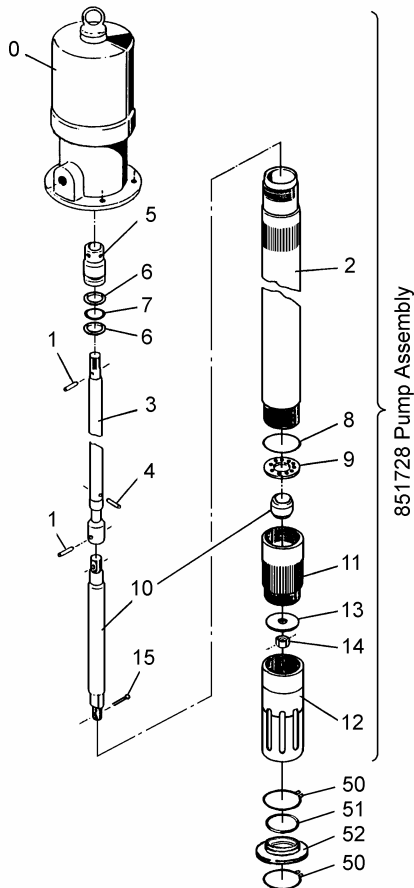

### 851999 PUMP ASSEMBLY

Item No.	Part No.	Description	Q'ty
0	802497	Air Motor Assembly	1

802752		Lower Pump Assembly	1
1	632773	Spring Pin	2
2	710617	Cylinder Tube	1
3	710618	Connecting Rod	1
4	632792	Spring Pin	1
5	710619	Piston	1
6	771367	Back Up Ring	2
7	682926	O-Ring	1
8	682922	O-Ring	1
9	701600	Valve Stopper	1
10	802751	Plunger Assembly	1
11	710620	Valve Case	1
12	710621	Booster Cover	1
13	710622	Shovel	1
14	627012	Nut	1
15	632032	Split Pin	1

50	630867	Stop Ring	2
51	640132	O-Ring	1
52	710995	Flange	1

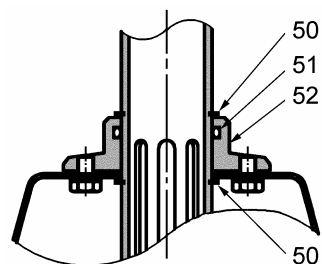

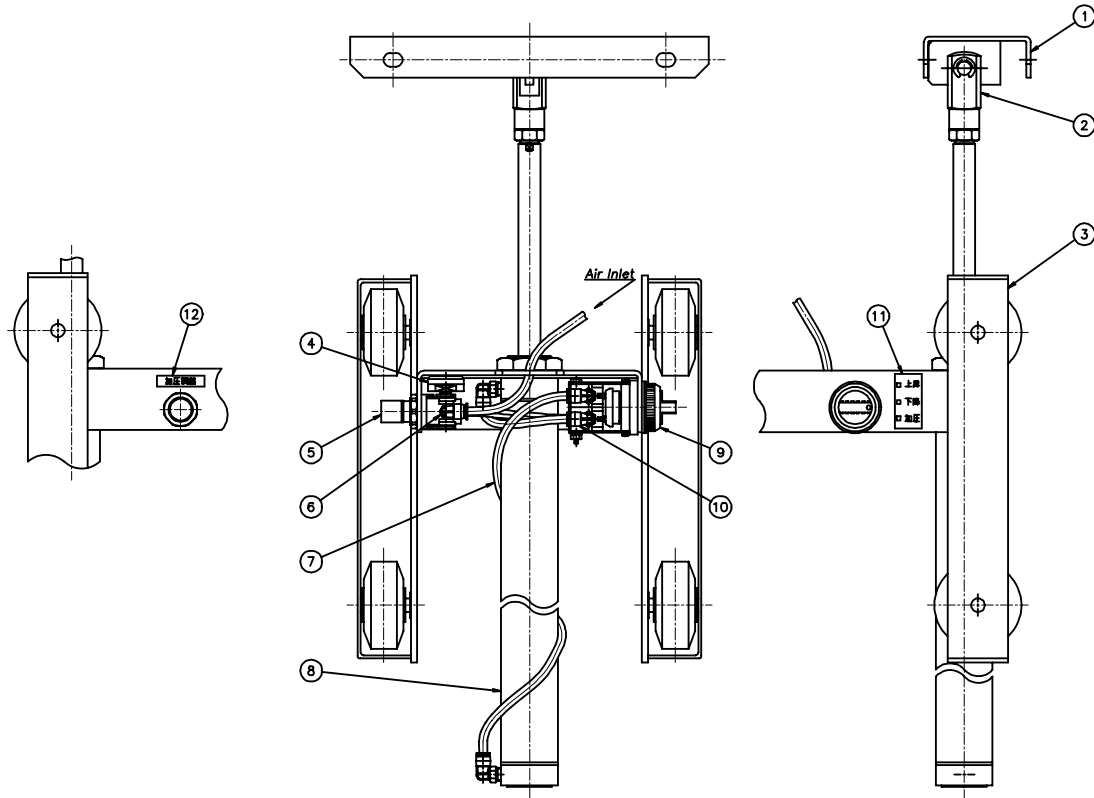

### 802470 ROLLER ASSEMBLY

Item No.	Parts No.	Description	Q'ty
1	831483	Lift Head Assembly	1
2	682935	Knuckle Joint	1
3	831549	Guide Roller Assembly	1
4	682630	Gauge	1
5	685404	Regulator	1
6	685381	Fitting	2
7	570072	Tube Ø 6	1
8	682875	Air Cylinder	1
9	682577	Switching Valve	1
10	682933	Fitting	5
11	(790557)	Label	1
12	(790558)	Label	1
13	772018	Cushion	1

## 9. Pump Specifications

<b>Type</b>		<b>SKR-110M50SAL</b>
Model No.		880677
Application		Pail can
Pump ratio		50 : 1
Material connection	Discharge port	G 1/4
	Suction port	Inductor Plate
Air connection	Air inlet	G 1/4
Operating range	Supply air pressure	0.3 to 0.7 MPa
Noise	0.3 to 0.7 MPa	Max. 80.5 dB(A) *1
Operating temperature range		0 to 80 °C
Pump Delivery		(Max. 1.2 kg/min)
Pump Outlet Pressure *2		(Max. 30 MPa)
Mass		38 kg

\*1 ; Operating noise measured at a distance of 1 meter from the surface of the machinery and at height 1.6 meters from the floor.

\*2 ; Refer to the performance curve.

### Performance Curve

#### Above conditions

Pump Delivery	Max. 1.2 kg/min
Pump Outlet Pressure	Max. 30 MPa
Air Consumption	Max. 0.7m <sup>3</sup> /min (ANR)
Air Pressure	0.7 MPa
Material	Grease NLGI #0
Grease Temperature	20 °C

#### NOTE

The continuous pump operation should be avoided if the desired delivery is in the range shaded in the figure below.

### Pump Engineering Data

Pump Model No.	851999
Pump Ratio	50 : 1
Air Motor Displacement	570 ml
Lower Pump Displacement	10.2 ml
Stroke Length	60 mm

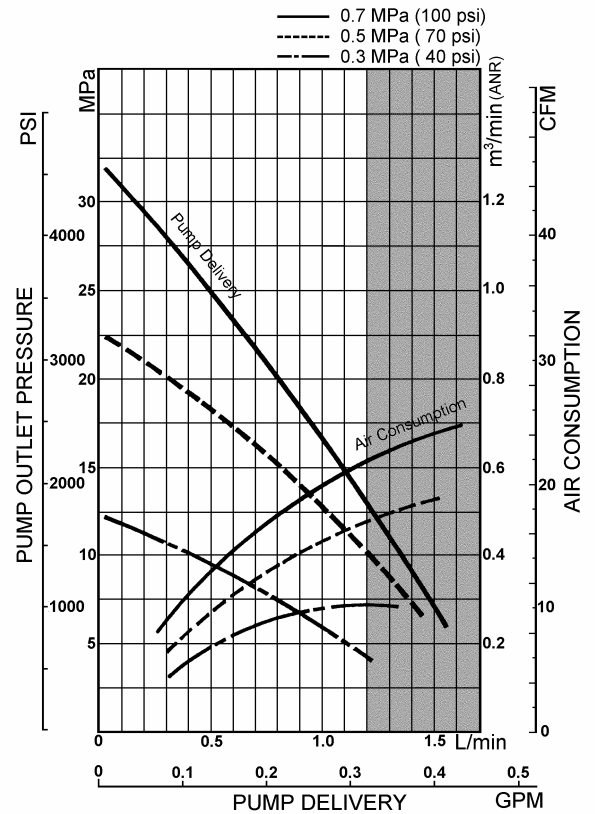

### Dimensions

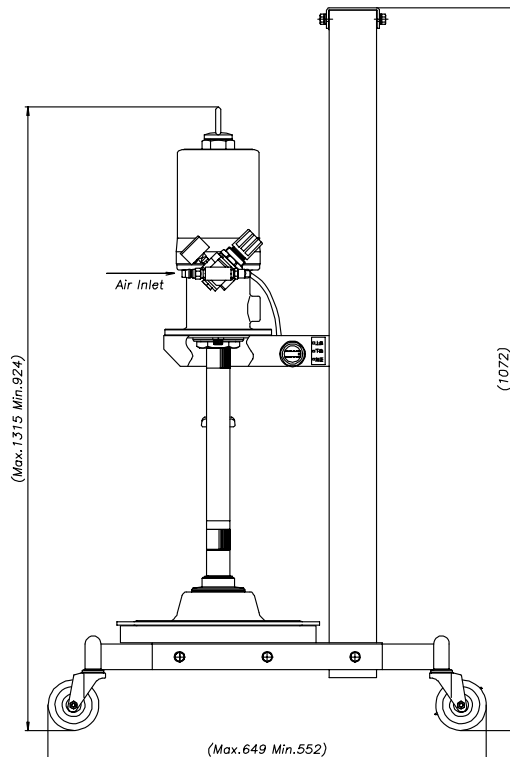
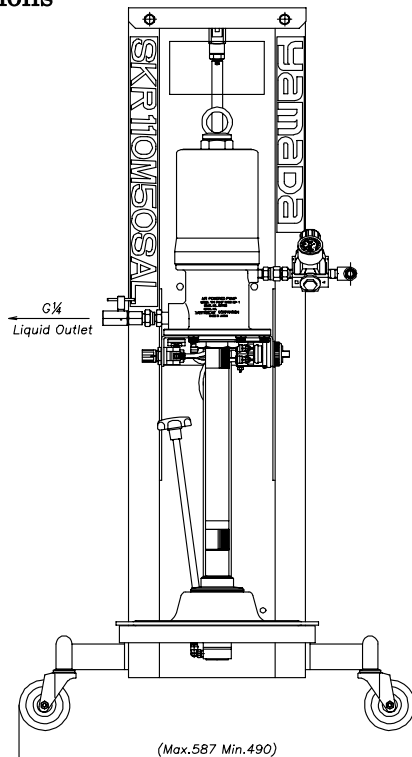



## 10. Limited warranty

This product is shipped to customers only after meeting strict inspection standards. If an abnormality occurs during normal operation in accordance with the operating instructions and other operating cautions within the warranty period (12 months after date of purchase) that can be attributed to a manufacturing defect, the defective parts of this product will be serviced or the product will be replaced free of charge. However, this warranty will not cover compensation for incidental damage or any malfunction listed below.

### 1. Warranty period

This warranty will be valid for a period of 12 months after the date of purchase.

### 2. Warranty

If, during the warranty period, any of the material of the genuine parts of this product or the workmanship of this product is found defective, and is so verified by our company, the servicing cost will be fully born by our company.

### 3. Exclusion

Even during the warranty period, this warranty does not cover the following:

- (1) Malfunction arising from use of parts other than manufacturer-specified genuine parts
- (2) Malfunction arising from misuse or operating errors, or lack of storage or maintenance care
- (3) Malfunction arising from use with a fluid that may cause corrosion, inflation or dissolution of the component parts of the product
- (4) Irregularity arising from repair made by other than by our firm, our regional office, dealer or authorized service personnel
- (5) Malfunction arising from modification of the product by other than authorized service personnel
- (6) Wear and tear of parts that must be regularly replaced in the course of normal operation, such as diaphragms, valve seats, balls, air switch sleeve valves and O-rings
- (7) Malfunction and/or damage due to transportation, moving or droppage of the product after purchase
- (8) Malfunction and/or damage due to fire, earthquake, flood or other force majeure
- (9) Malfunction arising from use of compressed air that contains impurities or excessive moisture, or use of gases or fluids other than the specified compressed air
- (10) Malfunction arising from use with a fluid that causes excessive abrasion or use of lubricating oil other than that specified for this product

Furthermore, this warranty does not cover the rubber parts, or other parts that are subject to wear in normal operation, used in this product and its accessories.

### 4. Parts

Parts for this product will be kept available for 5 years after discontinuation of production. Once 5 years have elapsed after close of production, availability of parts for this product cannot be guaranteed.

**YAMADA CORPORATION**  
**INTERNATIONAL DEPARTMENT**

No.1-3, 1-Chome, Minami-Magome, Ohta-Ku, Tokyo, 143-8504, Japan  
PHONE: +81-(0)3-3777-0241  
FAX: +81-(0)3-3777-0584

200812 OSA041U