

INSTRUCTION

High Viscosity Material Supply Pump Unit (Pail) 140 type series

SR140P25PWAL-F	MODEL No.881107
SR140P38PWAL-F	MODEL No.881108
SR140P50PWAL-F	MODEL No.881109
SR140P25PWAL-T	MODEL No.881110
SR140P38PWAL-T	MODEL No.881111
SR140P50PWAL-T	MODEL No.881112

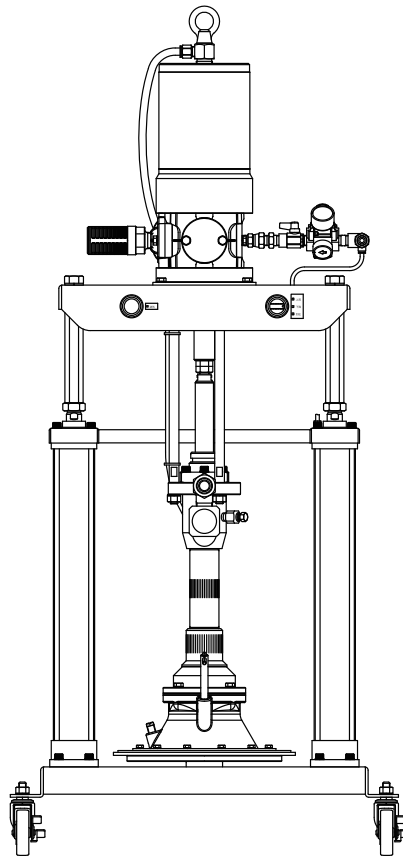

WARNING

Prior to operating this pump, be sure to read this operation manual for safety. After reading the manual, please keep it at hand any time for your quick reference.

- Preface

Thank you very much for purchasing Yamada Pump.

The SR-140PWAL series is air operated pump units designed for use with a 20 litre pail. With a combination of a type 140 air powered pump and an air operated lift, the unit is suitable for transferring/supplying high viscosity materials like grease.

Through pipes and hoses, material can be supplied to various sections of a work site. At each section, you can use material anytime just by controlling an outlet valve.

The inductor plate provides a tight seal between the plate and a pail, prevents the forming of an air pocket in the suction port, and helps to pump and transfer material efficiently until a pail gets empty.

There are two types of inductor plates: Flat packing type (F) and Tube packing type (T). You can choose the appropriate one depending on material and its viscosity.

Furthermore, in the flat packing type, a punch plate is attached on the bottom of the inductor plate to make it possible to use up material in a pail as much as possible.

The lift has removable caster wheels on the bottom. You can move the whole unit with a pail mounted. By removing these wheels, the unit can be secured to the floor using anchor bolts.

- For Safe Operation

This document describes the items that are important for the user to operate this product safety, correctly, and efficiently.

Before operating this product, read this manual thoroughly, in particular, "Warnings and Cautions" at the beginning of this manual, with a good understanding of its contents. Keep this manual carefully in an easy-to-access place so that the user may refer to it whenever necessary.

- Warnings and Cautions

To use this product safely, be sure to observe the contents of the following description. In this manual, warnings and cautions are indicated by using symbols. These symbols are intended to prevent death or serious injury that may be caused to the operator or those who are around the product and damage that may be caused to the articles that are around the product, as well as to use the product safely and correctly. Each symbol is indicated and has a meaning as shown below. Read the description with a good understanding of its contents.



WARNING : This indicates the existence of potential hazard which, if not avoided, will result in death or serious injury.



CAUTION : This indicates the existence of potential hazard which, if not avoided, may result in bodily injury or in physical damage.

To indicate the contents of danger and damage, the following symbols are used together with the above indications.



This symbol indicates an act that is prohibited (prohibition). The concrete contents of prohibition are indicated by the side of the indication.



This symbol indicates the contents that must be observed. The concrete contents of observance are indicated by the side of the indication.

- Precautions on Use

The following warnings and cautions are very important. Be sure to observe them.

WARNING

[Operating condition]



- Read this manual thoroughly before use.
For your safety, read and understand all information provided in this manual.
If you have lost or damaged your instruction manual, please contact us or our distributor to place an order.



- Restriction on handling
Never let anyone operate this unit without understanding this manual.

[Operating method]



- Understand this manual completely before operating the machine.
Operators and maintenance personnel are required to read this manual thoroughly before operating or servicing. Do not handle this machine without understanding the instructions.



- Do not use inappropriately.
Use of the product for any purpose other than those specified in this manual may result in personal injury or property damage. Be sure to use the unit in accordance with the specifications described in "6. Specifications" in this manual.

[Disassembly, maintenance and inspection]



- Shut off air supply.
Performing these tasks when air supply is on may cause a sudden movement of the lift or an unexpected discharge of material. Be sure to shut off the air source to stop the machine before servicing.







- No alternation is permitted.
Alternating the unit may result in personal injury or product malfunction. Please do not try to alter, modify, or change the machine.







- Replacement time for consumables
The life of consumables varies depending on operating conditions. Replace a degraded part with a new one.

CAUTION

[Installation and piping]

-  - Install an emergency stop valve.
Attach an emergency stop valve to the air piping (somewhere accessible between the air source and unit) and close this valve in case of emergency.
-  - Stop operation.
If any abnormality is found during operation, immediately stop the machine. Do not restart until the cause has been identified and corrected.
-  - Shut off air supply.
Shut off the air source BEFORE installation and piping.
-  - Install properly.
Install the unit properly according to the requirements for location and material, pressure resistance, and size of hoses and other device, avoiding lift operation failure and pipe leakage or breakage.
-  - Do not plumb directly.
Do not connect the material outlet and piping directly. Attach a flexible tube like a hose to connect the pump to the piping. The pump, if connected directly to the piping, may cause many problems (e.g., noise caused by vibration, damage to the piping, operation failure of the lift, and failure of maintenance).

[Handling]

-  - Do not put your hand or any other part of your body between the inductor plate and a pail.
Be aware that the lift, when operated at 0.5MPa air pressure, will generate about 270kgf (press force). Be sure to set the lift air regulator normally at 0.4MPa and NEVER exceed the maximum operating pressure of 0.7MPa.
-  - Do not touch the speed control on the air cylinder of the lift.
The lift speed is maintained at a constant level (factory setting).
-  - In case of emergency
Close the emergency stop valve.
-  - Air pressure to the unit
Set the primary air pressure to 1.0MPa or less.
-  - Air pressure to the pump
Set the pump air regulator to 0.7MPa or less.

[Shutdown and storage]

-  - When left unused for a long time (an hour or more) or shutdown
In such case, close the air source and open the bleeder valve to release residual pressure inside the pump. (Close the bleeder valve after the residual air and material is removed.)
If a drum is not mounted, move the lift to the lower limit and put a plastic bag over the inductor plate to prevent dust.

Table of Contents

- Preface
- For Safe Operation
- Warnings and Cautions
- Precautions on Use
- Table of Contents
- 1. Part Names**
 - 1.1 Part names 1
 - 1.2 Contents of a package 2
- 2. Installation**
 - 2.1 Lift installation 3
 - 2.2 Discharge piping 4
 - 2.3 Air piping 4
 - 2.4 Pump installation 4
- 3. Operating Method**
 - 3.1 Description of control and valve 6
 - 3.2 Placement of pail 7
 - 3.3 Operation 8
 - 3.4 Replacement of pail 9
 - 3.5 After work 9
- 4. Maintenance and Inspection**
 - 4.1 Maintenance and inspection 10
 - 4.2 Troubleshooting 11
 - 4.3 Consumables 12
 - 4.4 Design standard use period 12
- 5. Parts Disassembly Drawing and Parts List** 13
- 6. Specifications**
 - 6.1 Unit specifications 17
 - 6.2 Pump specifications 17
 - 6.3 Dimensions 18
- 7. Trouble Information Fax Form** 19
- 8. Limited Warranty** 21

1. Part Names

1.1 Part names

Fig. 1 and Fig. 2 show the names of each part used in the instructions in this manual. Use them as a reference.

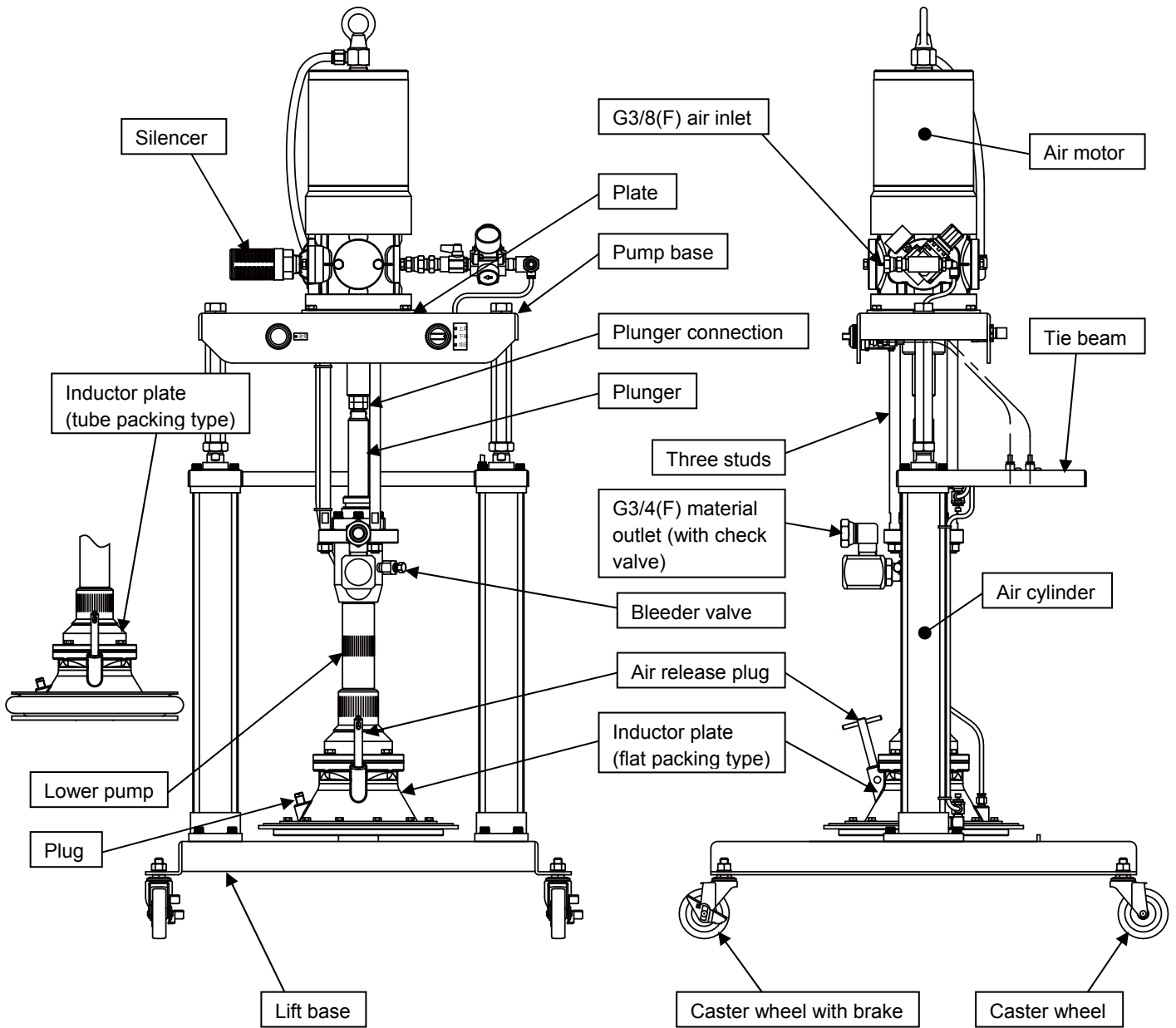

Fig. 1 Part names

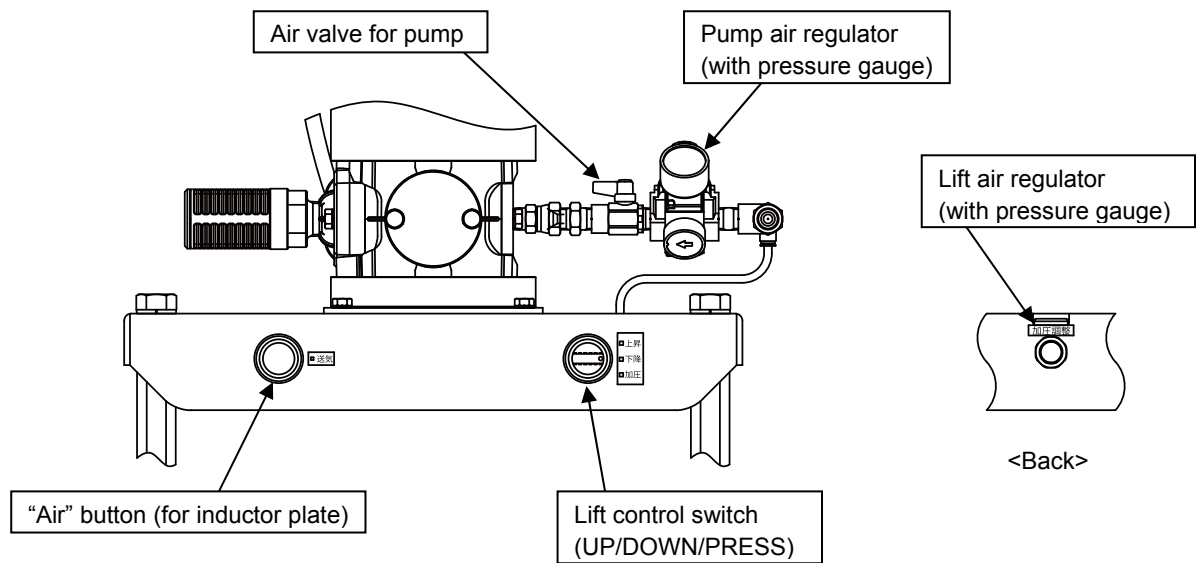







Fig. 2 Names of operation part

1.2 Contents of a package

The unit is packed in a wooden box.

Open the box and inspect the product to make sure there is no part damaged or loosened due to vibration during transport.

2. Installation

 CAUTION	
	- This unit rises up to a full height of 1850mm. Be sure to have enough space around the unit when installing.
	- Be sure to turn each air regulator all the way to the left (counterclockwise) BEFORE connecting hoses.
	- Keep yourself away from the lift when operating it. Do not touch any part of the unit other than the switches on the operation panel.
	- Do not put your hand or any other parts of your body between a drum and the inductor plate when installing a drum. An unexpected body injury may be caused.

2.1 Lift installation

- 1) Install the lift in your work site. Make sure the environment satisfies the following conditions:
 - A flat surface indoor (area where exhaust from the pump does not affect peripheral equipment)
 - Enough space for up/down movement of the lift (full height of the lift: 1850mm)
 - Enough space to perform maintenance
- 2) When using caster wheels:

Make sure the front caster wheel locks are both locked during pump operation (including lift operation). Keep the caster wheels locked whenever machine is not being moved.
- 3) When anchoring the unit to the floor:

Remove all the caster wheels from the lift base. Using M12 anchor bolts, secure the unit to the floor that satisfies the installation requirements above.

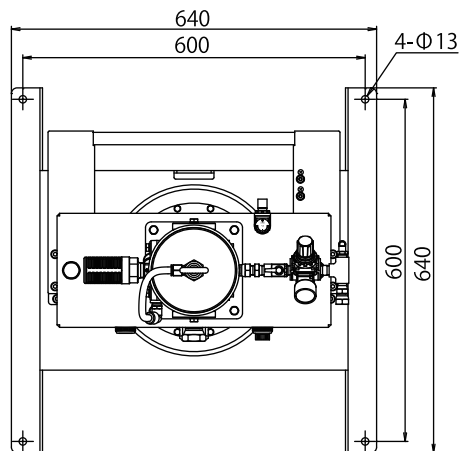

Fig. 3 Mounting dimensions for floor anchoring





2.2 Discharge piping

- 1) Connect a discharge hose to the pump outlet. Make sure the hose satisfies the following requirements:
 - Resistant to material being pumped and unaffected by environment
 - Satisfying the following normal operation pressure:
 - 25×1 ratio pump: 18MPa or more
 - 38×1 ratio pump: 27MPa or more
 - 50×1 ratio pump: 35MPa or more
 - Recommended size: 3/4 inch or more
 - Comfortable hose length for up/down movement of the lift
 - Hose fitting or joint: Connectable to G3/4(F) material outlet, hose union with a 30 degree male seat.
- 2) Connect the other end of the hose to a delivery pipeline. Attach a valve at the connection between the hose and the piping for maintenance and keep it closed until unit installation is completed.

2.3 Air piping

- 1) Attach an emergency stop valve to the air pipe (somewhere accessible between the air source and unit).
- 2) Select an air supply hose, fitting, and air equipment that satisfy the following requirements. With these devices, connect an air piping and the air inlet of the lift. Be careful not to let the hose get caught on peripheral equipment.
 - Designed for use with air and unaffected by environment
 - Normal operation pressure: 0.7MPa or more
 - Recommended size: 3/8 inch or more
 - Hose fitting or joint: Connectable to G3/8 air inlet
 - Comfortable hose length for up/down movement of the lift
 - Flow rate: 1300L/min (ANR) or more

2.4 Pump installation

 CAUTION	
	- The pump weighs about 30kg. Use a chain block for installation to prevent injury. Be very careful during installation.
	- Before installing the pump, verify that the shovel at the bottom is NOT sticking out. Failure to follow this instruction may result in damage to the shovel rod causing a pump failure. (Fig. 4)
	- Do not put your hand between the pump body and shovel. Hand injury may be caused by a sudden movement. (Fig. 4)

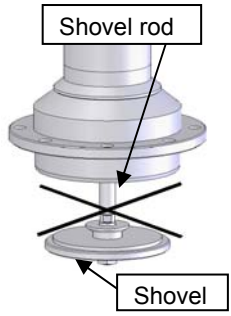

Fig. 4 Shovel part

Normally, the product is delivered with the pump already installed. If you have dismantled the pump for maintenance or replacement, mount it again according to the following procedure. The lift is compatible with any of the following pumps: SR140P25-P (854557), SR140P38-P (854558), SR140P50-P (854559)

① Mounting pump on lift

Remove the check valve from the outlet of the pump.
Lift the pump using the eye nut on the top. Put the mounting plate of the pump on the pump base of the lift. Align the holes on the mounting plate with the screw holes on the pump base. Insert four bolts with wave spring washers and tighten them securely. (Fig. 5)
Wrap sealing tape around the thread of the check valve and put the valve back.

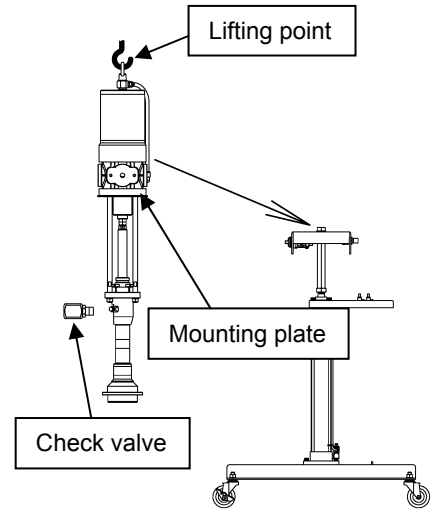

Fig. 5 Mounting pump on lift

② Connecting pump to inductor plate

Insert the lower part of the pump through the gasket into the inductor plate. Rotate the holes in the gasket and flanged part of the pump to align with the bolt holes in the inductor plate. Insert bolts with wave spring washers through each hole and tighten them securely. (Fig. 6)
Make sure the air release plug is positioned in the front side of the pump facing away from the bleeder valve.
Insert the air tube hanging from the "AIR" button into the inductor plate. (Fig. 7)

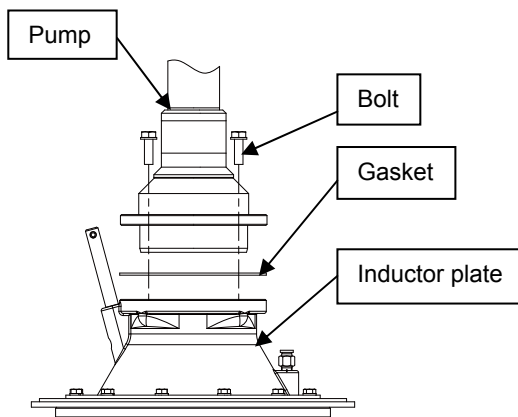

Fig. 6 Connecting pump to inductor plate

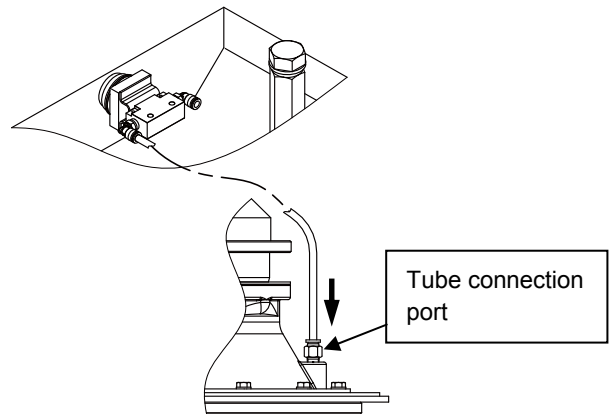

Fig. 7

③ Connecting delivery piping

Refer to "2.2 Discharge piping".

④ Connecting air piping

Connect air piping equipment such as an air valve and air regulator to the air inlet of the pump by referring to "2.3 Air piping". Also, connect an air tube to the lift. (Fig. 8)

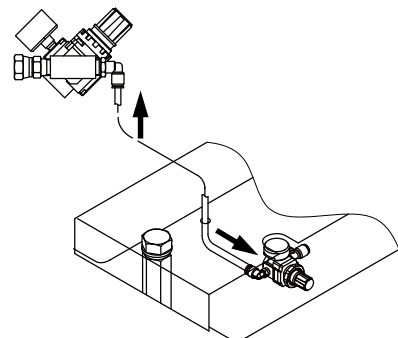











Fig. 8

3. Operating Method

CAUTION

-  - Keep your face away from the bleeder valve. Material may spurt out together with compressed air.
-  - Do not exceed the maximum operating pressure of the pump (0.7MPa). Overpressure may cause a product failure resulting in serious personal injury and/or property damage.
-  - The maximum operating pressure of the lift is 0.7MPa. Overpressure may cause a product failure resulting in serious personal injury and/or property damage. Do not exceed this limit. At the "PRESS" mode, be careful not to put excess pressure on the lift. Material may escape through the side of the packing around the inductor plate.
-  - Keep your hand away from the three studs connecting the air motor and lower pump. Fingers can get caught in the reciprocating plunger.
-  - If a defect occurs during lift operation, immediately stop the lift by adjusting the lift control switch to "DOWN" or shut down air supply to the unit.
-  - Keep yourself away from the lift when operating it. Do not touch any part of the unit other than the control switches.
-  - Do not put your hand or any other parts of your body between a pail and the inductor plate when installing a pail. An unexpected body injury may be caused.
-  - To prevent excessive pressure in a pail, do not push the "AIR" button when the lift control switch is set to "PRESS".
-  - If the "AIR" button is pushed when there is still material in a pail, air bubbles will form in material.
-  - When the lift stops due to a foreign object caught in the sliding part, be sure to move the lift to the opposite direction BEFORE removing an object. The lift may suddenly start moving if a foreign object is removed directly.

3.1 Description of control and valve

- Pump Air Regulator

Function : Controlling air pressure for pump operation.

To operate: Clockwise turn will increase pressure. Counterclockwise turn will decrease pressure.

(It can be locked by pushing the knob in.)

Note : The maximum allowable operating pressure of the pump is 0.7MPa. DO NOT exceed this limit.

Remark : Discharge pressure can be calculated by multiplying the air pressure by the pump ratio.

- Air Valve, Pump (ball valve attached to the right side of pump air control)

Function : Starting/Stopping the pump.

To operate: When the lever is parallel to the pipe, the valve is open. If the lever is perpendicular to the pipe, the valve is closed.

Note : In case of emergency, close the emergency stop valve attached to the air piping instead of this valve.

- Lift Air Regulator

Function : Controlling air pressure for lift and inductor plate operation.

To operate: Clockwise turn will increase pressure. Counterclockwise turn will decrease pressure.

(It can be locked by pushing the knob in.)

Note : Set the normal operating air pressure to 0.4MPa.

- **Lift Control Switch (UP/DOWN/PRESS)**

Function : Raising/Lowering the lift.

“UP”-----Used when raising the lift. The lift moves up by air pressure.

“DOWN”--Used when lowering the lift. The lift moves down by its own weight.

“PRESS”-Used when setting the inductor plate in a pail and filling the inductor plate with material.

The lift speed is maintained at a constant level by the speed controller attached on the air inlet of the air cylinder of the lift.

To operate: Adjust the switch to each position depending on the intended use.

Note : At the “PRESS” mode, be careful not to put excess pressure on the lift. Material may escape through the side of the packing around the inductor plate. Also, do not push “AIR” button during the “PRESS” mode.

- **AIR button, Inductor Plate**

Function : Separating the inductor plate from a pail when a pail becomes empty.

To operate: Air is supplied as long as the button is depressed.

Note : Pressing the button when a pail is not empty may be a cause of air bubbles in material.

- **Bleeder Valve**

Function : Removing air from the pump and inductor plate after setting the inductor plate in a pail.

To operate: Holding the hexagonal head with a wrench (13mm), counterclockwise turn will open the valve.

Clockwise turn (all the way) will close the valve. 3-4 turns will be enough for bleeding.

Note : Be sure to close the valve securely after releasing air.

- **Air Release Plug**

Function : Removing air from the pump and inductor plate when setting the inductor plate in a pail. Open the plug before inserting the inductor plate into a pail and close it once material comes out of the air release hole.











To operate: Open and close by turning the plug holding the handle on the top by hand. Left turn will loosen the plug. Right turn will tighten the plug. Be sure to securely turn it when closing (tightening).

3.2 Placement of pail

- 1) Adjust the lift control switch to “DOWN” before turning on air supply.
- 2) Gradually increase lift air pressure to 0.4MPa by adjusting the lift air regulator knob. Then adjust the lift control switch to “UP” to raise the lift to the full height.
- 3) Turn the air release plug on the inductor plate 2-3 times counterclockwise to loosen it.
- 4) Place a 20 litre pail right under the inductor plate.
- 5) Turn the lift control switch to “DOWN” to lower the lift.
- 6) If the inductor plate and a pail are not concentric when the inductor plate reaches the brim of a pail, set the lift control switch to “UP” to raise the lift and then readjust the position of a pail.
- 7) If the inductor plate cannot be inserted into a pail smoothly when the inductor plate reaches the brim of a pail, set the lift control switch to “PRESS” to release the air built up between the inductor plate and material via the air release plug. Keep releasing air until material comes out of the air release plug.
- 8) Once the air inside the inductor plate is completely released, adjust the lift control switch to “DOWN” and tighten the air release plug.
- 9) In the event material doesn't come out of the air release hole even though the lift control switch is set to “PRESS”, please follow the following procedure:
 - ①Close the air release plug on the inductor plate.
 - ②Close the valve on the piping to prevent material from being discharged.
 - ③Open the bleeder valve by turning it 3-4 times for releasing air.
 - ④Open the air valve for the pump and increase air pressure gradually with the pump air regulator. The pump will start operating at approx. 0.05MPa. Adjust the pump air regulator to set pump speed to 5-8 seconds per cycle.
 - ⑤Set the lift control switch to “DOWN” to allow material to come out of the bleeder valve.
 - ⑥Once material comes out, adjust the lift control switch to “DOWN” and close the bleeder valve. Then, close the air valve for pump and set the pump air regulator to 0MPa.

3.3 Operation

CAUTION

-  - Material, if containing air bubbles, may gush out when discharged. Put a plastic bag over the material outlet to receive spurting material.
-  - Do not exceed the maximum operating pressure of the pump (0.7MPa). Overpressure may cause a product failure resulting in serious personal injury and/or property damage.
-  - The maximum operating pressure of the lift is 0.7MPa. Overpressure may cause a product failure resulting in serious personal injury and/or property damage. Do not exceed this limit. At the "PRESS" mode, be careful not to put excess pressure on the lift. Material may escape through the side of the packing around the inductor plate.
-  - Keep your hand away from the three studs connecting the air motor and lower pump. Fingers can get caught in the reciprocating plunger.
-  - If a defect occurs during lift operation, immediately stop the lift by adjusting the lift control switch to "DOWN" or shut down air supply to the unit.
-  - Keep yourself away from the lift when operating it. Do not touch any part of the unit other than the control switches.
-  - Do not put your hand or any other parts of your body between a pail and the inductor plate when installing a pail. An unexpected body injury may be caused.
-  - To prevent excessive pressure in a pail, do not push the "AIR" button when the lift control switch is set to "PRESS".
-  - If the "AIR" button is pushed when there is still material in a pail, air bubbles will be produced in material.
-  - When the lift stops due to a foreign object caught in the sliding part, be sure to move the lift to the opposite direction BEFORE removing an object. The lift may suddenly start moving if a foreign object is removed directly.

- 1) When filling the delivery piping with material for the first time, the air inside the piping will blow out. Please follow the following procedure.
 - ① Put a plastic bag over the material outlet to receive discharged material.
 - ② Open the valve on the delivery piping.
 - ③ Open the air valve for the pump and set the pump air regulator for minimum operating pressure.
 - ④ The pump will start discharging material from the outlet. Once the air in the piping is released completely, close the air valve for the pump and set the pump air regulator to 0MPa.
 - ⑤ The pump is now ready for operation.
- 2) Adjust the pump air regulator to set to the desirable operating pressure. An estimate of the material discharge pressure to the supply air pressure is calculated by "supply air pressure × pump ratio".
(e.g. When operating a 38:1 ratio pump at 0.7MPa supply air pressure, material will be discharged at approx. 26.6MPa.)

<NOTE>

Material viscosity changes with seasons. It is recommended to make a note of appropriate pressure for each season.

3.4 Replacement of pail

CAUTION



- Do not try to separate the inductor plate from a pail at once with the “PRESS” button depressed. Compressed air built up inside a pail may be released causing a spurt of residual material.

- 1) When a pail becomes empty, the pump will run dry and NOT stop automatically. Close the pump air valve and adjust air pressure to 0MPa using the pump air regulator.
- 2) Set the lift control switch to “UP” to raise the lift to the upper limit.
- 3) Press the “AIR” button a few times to allow air to flow between the inductor plate and a pail. A pail will be gradually separated from the inductor plate by rotating it. When a pail is hard to remove, push the “AIR” button several times again and then rotate a pail slowly to separate it from the inductor plate.
- 4) Once the inductor plate is separated from a pail, set a new pail according to the procedure described in “3.2 Placement of pail”.

3.5 After work

CAUTION



- After work or when shutting down the unit for a long period, be sure to turn off the air supply source to disconnect air supply to the pump, and open the valves on the material outlet or gun to release residual pressure inside the pump and piping. Failure to shut off air may cause damage to the hoses and pipes and/or leak in the valves and gun. Any secondary accidents caused by the failure mentioned above are the responsibility of the users.

- 1) Close the air valve for the pump and set the pump air regulator to 0MPa.
- 2) Set the lift control switch to “DOWN”.

<NOTE>





[Air release plug on inductor plate]

- When using the “air release plug” for the first time, it should be positioned on the upper side to release air more efficiently.
- It's recommended that if there is no residual material inside the inductor plate, when replacing a pail, position the “air release plug” on the upper side and release air. Also if material is left inside the inductor plate, switch the position of the “air release plug” and the “plug” to release air from the lower hole. However, this may not be applied to some materials or situations.

[Filter on inductor plate (flat packing type)]

- In the flat packing type, a punch plate is attached on the bottom of the inductor plate to make it possible to use up material in a pail as much as possible.

4. Maintenance and Inspection

 CAUTION	
	- Be careful not to allow the pump and lift to accidentally operate during maintenance and inspection.
	- When performing maintenance or inspection, notify workers by hanging a sign or other method to keep them from touching the unit.
	- Gasoline is a high volatile fuel. Never use it for cleaning of the unit. Risk of fire or explosion may exist.

4.1 Maintenance and inspection

INTERVAL	ACTION
Daily	①Inspect operation of pump.
	②Inspect operation of lift.
Weekly	③Lubricate pump. (turbine oil, class#1, additive-free: ISO V 32)
Annually	④Check for loose bolts and nuts.
Triennially	⑤Overhaul pump.

①Inspect operation of pump

Inspect pump to ensure the following:

- The pump operates normally and smoothly,
- There is no air/material leak in each part of the pump or air/material piping,
- There is no abnormal noise during pump operation, and
- There is no abrasion or deterioration apparently in each part of the pump.

②Inspect operation of lift

Inspect lift to ensure the following:

- The lift operates normally and smoothly,
- There is no air leak in air piping of the lift,
- There is no abnormal noise during lift operation, and
- There is no abrasion or deterioration apparently in each part of the lift.

③Lubricate pump

Lubricate pump according to the following procedure:

- Close the air valve for the pump and set the pump air regulator knob to 0MPa.

(With a lubricator)

- Disconnect the air piping from the air inlet of the pump and apply a few drops (approx. 0.5mL) of lubricant directly to the pump.

(Without a lubricator)

- Check the amount of oil remaining in the lubricator and fill it with lubricant if needed.

④Check for loose bolts and nuts

Check bolts and nuts according to the following procedures:

- Completely shut down the pump and lift by disconnecting from the air source, for example.
- Ensure that all visible bolts and nuts on the pump and lift cannot be loosened by hand.

⑤Overhaul pump

Pump needs to be overhauled triennially. Please contact the retail store where you purchased your pump or our business office for overhaul. Earlier overhaul is recommended depending on use frequency and deterioration degree.

4.2 Troubleshooting

If you suspect that you have a problem with your product, consult the table below for some common problems and their solutions. Contact the retail store where you purchased your product or our business office if all else fails.

PROBLEM	POSSIBLE CAUSE	REMEDY
Pump doesn't run	Compressor is off.	Turn on compressor.
	Valve on air piping is closed.	Open valve.
	Air pressure setting is under 0.2MPa.	Set air pressure to 0.2MPa or above.
	Valve on material outlet is closed.	Open valve.
	Frost occurs inside silencer.	Use dry air.
	O ring on sliding part of air piston is worn out. (Air leak occurs from silencer.)	Replace worn out or damaged part.
	Block (773065) and ball (686271) in valve body (804815) are worn out. Any parts (e.g. spring, pin) used in switching system in valve body (804815) or air motor (804814) are damaged.	
Air leak from air motor	- Fasteners are loose. - O rings and packings are worn out.	- Retighten loose parts. - Replace worn part.
Air leak from silencer during shutdown	- Foreign object is caught between block (773065) and valve seat (716246) in valve body (804815). - Seating part is worn out.	- Remove foreign object. - Replace worn part.
Pump doesn't run and air leaks from silencer	- Foreign object is caught between spindle (716299) and valve switcher (832996) in air motor (804814). - There exists damage that prevents sliding movement of parts below.	- Remove foreign object. - Replace damaged part.
Pump doesn't draw material at first time of operation	Pump operating speed is so fast that lower pump suction cannot keep up with pump movement. (Valve inside lower pump is not working well.)	Set pump speed to 5-8 sec. per cycle until material is pumped out.
Material cannot be pumped out	If upward movement of plunger is faster, - seat surface of piston valve is defective (wear of seat surface, inclusion of foreign material) or, - packings are damaged.	- Remove foreign object. - Replace damaged part.
	If downward movement of plunger is faster, - seat surface of foot valve is defective (wear of seat surface, inclusion of foreign material), - packings are damaged, or - shovel rod is bent.	
	If downward movement of plunger is faster, operating speed is so fast that lower pump suction cannot keep up with pump movement. (Vacuum is caused inside lower pump.)	Decrease air pressure until material comes out. (This pressure is the upper limit of normal operating pressure.)
	Connecting rod connecting air motor and lower pump is completely separated from air motor. (In this case, parts inside of lower pump may be damaged.)	Inspect inside lower pump first, then replace damaged part, and retighten each part.
Pump doesn't stop	Leak occurs in delivery pipe.	- Retighten loose parts. - Replace damaged part.
	Leak occurs in lower pump (connections are loosened or o ring, backup ring, or packing is damaged).	
Material leak from lower pump	- Fasteners are loose. - O ring, backup ring or packing is damaged.	- Retighten loosened parts. - Replace damaged part.
Material contains air bubbles even after bleeding	Internal diameter of pail is larger than specified.	Use JIS-approved pail.
	Air release plug is loosened.	Secure air release plug.
	Packing of inductor plate is deteriorated.	Replace packing.
	- Fasteners are loosened. - O ring or backup ring is damaged.	- Retighten loosened parts. - Replace damaged part.
Material leak around inductor plate	Internal diameter of pail is larger than specified.	Use JIS-approved pail.
	Pail surface is uneven.	Use straight side pail.
	Packing of inductor plate is deteriorated.	Replace packing.
Lift doesn't move up/down	Compressor is off.	Turn on compressor.
	Air supply is off.	Turn on air supply.
	Air pressure setting is not enough.	Set air pressure to 0.4MPa.
	Pail surface is uneven.	Use straight side pail.
	Cylindrical section of lift air cylinder is dent.	Replace part.

4.3 Consumables

1) Pump

Refer to “Instruction Manual for APP 067U” for replacement time for consumables used in the pump. The replacement time should be used only as a guide. Consumption varies depending on use conditions. Also, be sure to replace a part when you find any defect like a leak during operation.

2) Lift

- The plastic tubes will be degraded naturally. Replace them all every six years.
- The switches and regulators should be replaced if you find they are not working properly. Never use a defective device.

3) Inductor Plate

- The packing will get worn out due to sliding contact with a pail.
- The gasket used for the connection between the pump and inductor plate will get worn out by repetitive mounting and removal of the inductor plate. Replace it with a new one when it is damaged at the time of inductor plate removal.

4.4 Design standard use period

Design standard use period is established for the product. (See the table below.)

Use of the product beyond this period may result in personal injury or property damage.

- Pump---Refer to “Instruction Manual for APP 067U”.

- Lift and inductor plate---10 years

Standard Conditions of Use for Lift and Inductor Plate	
Application	Pumping and transferring grease
Season	Spring and Fall
Temperature	20°C
Material being pumped	Lithium Soap Grease: No.1
Container	Steel pail (20L): JIS Z 1620
Operating pressure for lift	0.4MPa
Daily Amount of Material being pumped	100L
Operating Days per year	260 days (5 days a week)

5. Parts Disassembly Drawing and Parts List

■Parts Disassembly Drawing (Flat Packing Type)

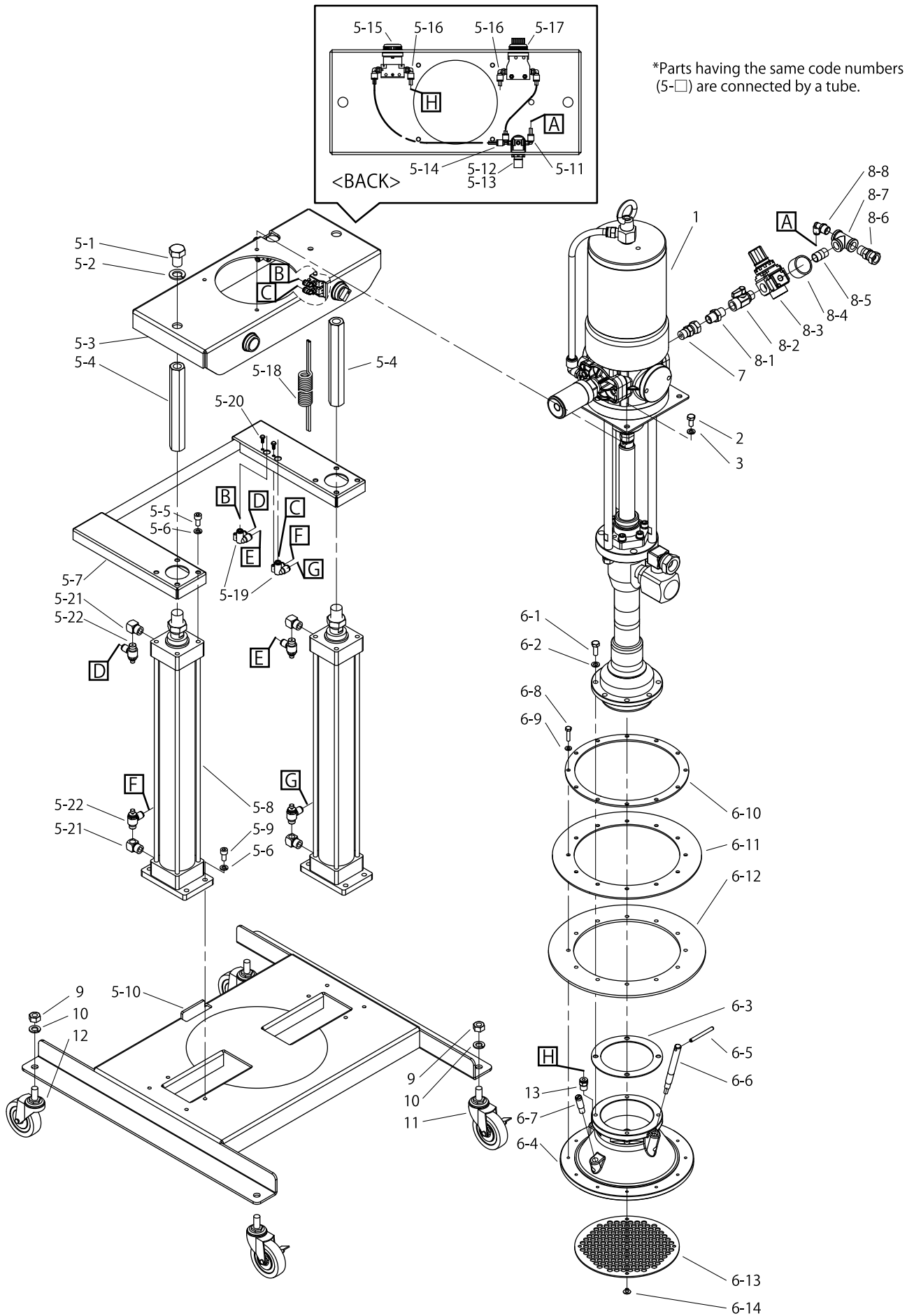

■Parts List (Flat Packing Type)

No.	Parts No.			Description	Qty
	SR140P25PWAL-F	SR140P38PWAL-F	SR140P50PWAL-F		
	<881107>	<881108>	<881109>		
1	854557	854558	854559	Pump assembly	1
2	611145			Bolt	4
3	631916			Wave spring washer	4
5	(854563)			Pail lift assembly	—
5-1	611276			Bolt	2
5-2	631921			Wave spring washer	2
5-3	716334			Pump base	1
5-4	716335			Rod	2
5-5	619145			Bolt	8
5-6	631916			Wave spring washer	16
5-7	832984			Tie beam assembly	1
5-8	686334			Air cylinder	2
5-9	619147			Bolt	8
5-10	716336			Lift base	1
5-11	685381			Elbow fitting	1
5-12	685404			Regulator	1
5-13	682630			Pressure gauge	1
5-14	684534			Tees fitting	1
5-15	684068			Mechanical valve	1
5-16	682933			Elbow fitting	5
5-17	682577			Mechanical valve	1
5-18	685929			Coiling tube	1
5-19	686335			Elbow fitting	2
5-20	686336			Tapping screw	2
5-21	684611			PT elbow	4
5-22	684897			Speed controller	4
6	(804819)			Inductor plate assembly	—
6-1	611149			Bolt	4
6-2	631916			Wave spring washer	4
6-3	772150			Gasket	1
6-4	716337			Follower plate	1
6-5	632837			Spring pin	1
6-6	716338			Plug	1
6-7	716339			Plug	1
6-8	611102			Bolt	12
6-9	631418			Spring lock washer	12
6-10	715755			Plate	1
6-11	770115			Packing	1
6-12	770114			Packing	1
6-13	716340			Filter	1
6-14	686331			Truss head screw	4
7	680109			Union adapter	1
8	(804821)			Regulator assembly	—
8-1	680140			Nipple	1
8-2	682772			Valve	1
8-3	684141			Regulator	1
8-4	682924			Pressure gauge	1
8-5	634803			Nipple	1
8-6	680109			Union adapter	1
8-7	634062			Tee	1
8-8	684550			Elbow fitting	1
9	627014			Nut	4
10	631918			Wave spring washer	4
11	686332			Caster with brake	2
12	686333			Caster	2
13	682893			Fitting	1

■Parts Disassembly Drawing (Tube packing type)

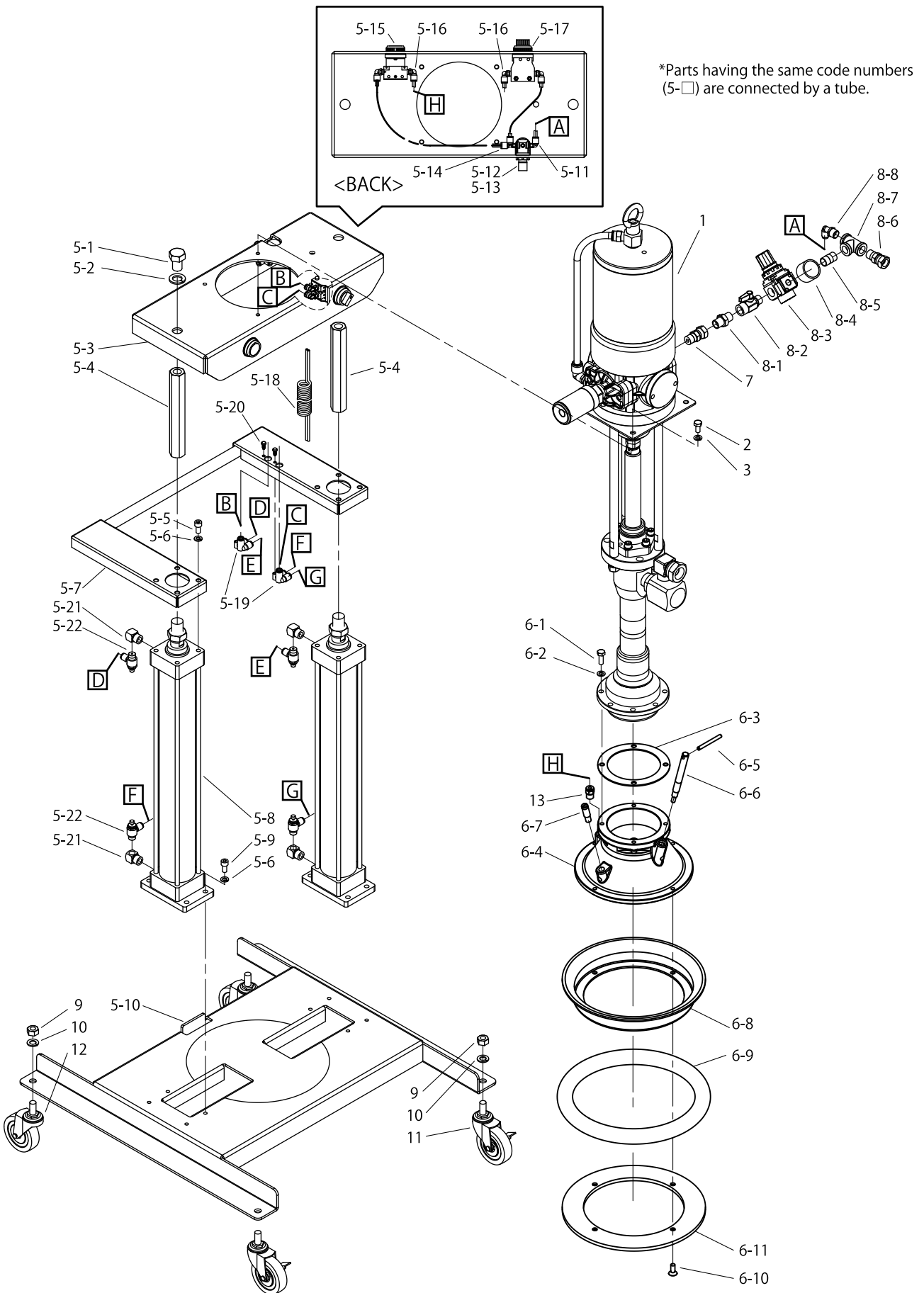

■Parts List (Tube Packing Type)

No.	Parts No.			Description	Q'ty
	SR140P25PWAL-T	SR140P38PWAL-T	SR140P50PWAL-T		
	<881110>	<881111>	<881112>		
1	854557	854558	854559	Pump assembly	1
2	611145			Bolt	4
3	631916			Wave spring washer	4
5	(854563)			Pail lift assembly	—
5-1	611276			Bolt	2
5-2	631921			Wave spring washer	2
5-3	716334			Pump base	1
5-4	716335			Rod	2
5-5	619145			Bolt	8
5-6	631916			Wave spring washer	16
5-7	832984			Tie beam assembly	1
5-8	686334			Air cylinder	2
5-9	619147			Bolt	8
5-10	716336			Lift base	1
5-11	685381			Elbow fitting	1
5-12	685404			Regulator	1
5-13	682630			Pressure gauge	1
5-14	684534			Tees fitting	1
5-15	684068			Mechanical valve	1
5-16	682933			Elbow fitting	5
5-17	682577			Mechanical valve	1
5-18	685929			Coiling tube	1
5-19	686335			Elbow fitting	2
5-20	686336			Tapping screw	2
5-21	684611			PT elbow	4
5-22	684897			Speed controller	4
6	(804820)			Inductor plate assembly	—
6-1	611149			Bolt	4
6-2	631916			Wave spring washer	4
6-3	772150			Gasket	1
6-4	716341			Follower plate	1
6-5	632837			Spring pin	1
6-6	716338			Plug	1
6-7	716339			Plug	1
6-8	716342			Wiper holder	1
6-9	770475			Wiper	1
6-10	602769			Screw	4
6-11	716343			Plate	1
7	680109			Union adapter	1
8	(804821)			Regulator assembly	—
8-1	680140			Nipple	1
8-2	682772			Valve	1
8-3	684141			Regulator	1
8-4	682924			Pressure gauge	1
8-5	634803			Nipple	1
8-6	680109			Union adapter	1
8-7	634062			Tee	1
8-8	684550			Elbow fitting	1
9	627014			Nut	4
10	631918			Wave spring washer	4
11	686332			Caster with brake	2
12	686333			Caster	2
13	682893			Fitting	1

6. Specifications

6.1 Unit specifications

Product No.		881107	881108	881109
Model		SR140P25PWAL-F (SR140P25-P)	SR140P38PWAL-F (SR140P38-P)	SR140P50PWAL-F (SR140P50-P)
Air Inlet		G3/8(F)		
Material Outlet		G3/4(F)		
Applicable Container		Steel pail equivalent to JIS Z 1620 or similar plastic container Height limit: 440 mm or less		
Primary Air Pressure		Max. 1.0 MPa		
Air Pressure for Lift Operation		0.2 ~ 0.7 MPa (normal operation pressure: 0.4MPa)		
Amb. Temp. Range	Env. Temperature	0 ~ 60 °C		
	Material Temp.	0 ~ 80 °C		
Weight		61.0 kg		

Product No.		881110	881111	881112
Model		SR140P25PWAL-T (SR140P25-P)	SR140P38PWAL-T (SR140P38-P)	SR140P50PWAL-T (SR140P50-P)
Air Inlet		G3/8(F)		
Material Outlet		G3/4(F)		
Applicable Container		Steel pail equivalent to JIS Z 1620 or similar plastic container Height limit: 440 mm or less		
Primary Air Pressure		Max. 1.0 MPa		
Air Pressure for Lift Operation		0.2 ~ 0.7 MPa (normal operation pressure: 0.4MPa)		
Amb. Temp. Range	Env. Temperature	0 ~ 60 °C		
	Material Temp.	0 ~ 80 °C		
Weight		63.0 kg		

* "-F" and "-T" at the end of each model indicate "Flat packing type" and "Tube packing type" respectively.

6.2 Pump specifications

Refer to "Instruction Manual for APP 067U" for pump specification.

6.3 Dimensions

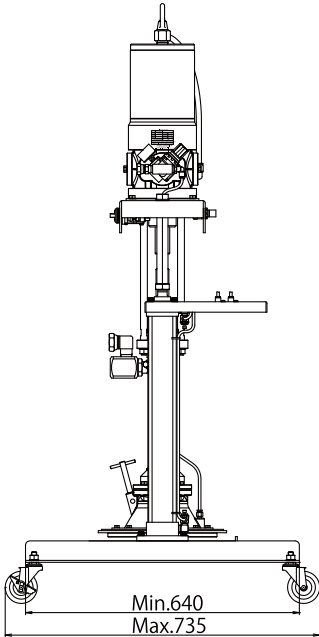
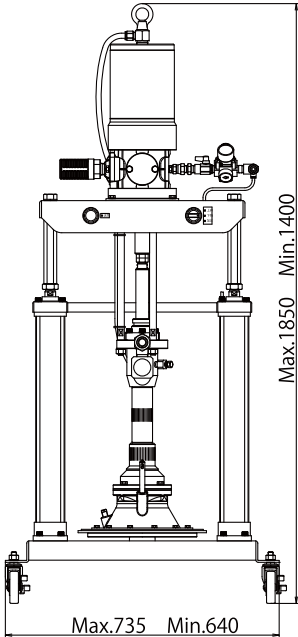

7. Trouble Information Fax Form

Complete necessary information in the following fax form since your information is necessary to find the cause of the trouble or failure and it enriches our repair services. After filling it, send it to us.

Trouble Information Fax Form	
Company name _____	Name _____
Address _____ _____	Department name _____
	Contact information Tel. () _____ - _____ Fax. () _____ - _____
Product name	Model
Duration of use 20__year__month to ____year__month	SERIAL No. (LOT No.)
Operation frequency <input type="checkbox"/> Continuous <input type="checkbox"/> Intermittent _____hour/day/week/month	Purchase date _____ Sales outlet _____
Machine conditions (descriptions of the trouble)	

8. Limited Warranty

If an abnormality occurs during normal operation in accordance with the operating instructions and other operating cautions within the warranty period (12 months after date of purchase) that can be attributed to a manufacturing defect, the defective parts of this product will be serviced or the product will be replaced free of charge. However, this warranty will not cover compensation for incidental damage or any malfunction listed below.

1. Warranty period

This warranty will be valid for a period of 12 months after the date of purchase.

2. Warranty

If, during the warranty period, any of the material of the genuine parts of this product or the workmanship of this product is found defective, and is so verified by our company, the servicing cost will be fully born by our company.

3. Exclusion

Even during the warranty period, this warranty does not cover the following:

- 1) Malfunction arising from use of parts other than manufacturer-specified genuine parts
- 2) Malfunction arising from misuse or operating errors, or lack of storage or maintenance care
- 3) Malfunction arising from use with a fluid that may cause corrosion, inflation or dissolution of the component parts of the product
- 4) Irregularity arising from repair made by other than by our firm, our regional office, dealer or authorized service personnel
- 5) Malfunction arising from modification of the product by other than authorized service personnel
- 6) Wear and tear of parts that must be regularly replaced in the course of normal operation, such as packings, O-rings
- 7) Malfunction and/or damage due to transportation, moving or droppage of the product after purchase
- 8) Malfunction and/or damage due to fire, earthquake, flood or other force majeure
- 9) Malfunction arising from use of compressed air that contains impurities or excessive moisture, or use of gases or fluids other than the specified compressed air
- 10) Malfunction arising from use with a fluid that causes excessive abrasion or use of lubricating oil other than that specified for this product

Furthermore, this warranty does not cover the rubber parts, or other parts that are subject to wear in normal operation, used in this product and its accessories.

4. Parts

Parts for this product will be kept available for 5 years after discontinuation of production. Once 5 years have elapsed after close of production, availability of parts for this product cannot be guaranteed.

Manufactured by

YAMADA CORPORATION

INTERNATIONAL DEPARTMENT

No.1-3, 1-Chome, Minami-Magome, Ohta-ku, Tokyo, 143-8504, Japan

PHONE : +81-(0)3-3777-0241

FAX : +81-(0)3-3777-0584

201108 OSA065U