

# YAMADA



*High Performance Air Operated  
Diaphragm Pumps*

[www.yamadacorp.co.jp/global](http://www.yamadacorp.co.jp/global)



**Engineered to Perform.  
Designed for Long Life.**

**Rugged, Bolted Construction**

All Yamada pumps feature bolted construction, which eliminates leaks and simplifies post-maintenance reassembly. Bolted construction is superior to clamp band retainers, which frequently require frustrating, unnecessary leakage rebuilds from misalignment during reassembly.

**Outside-Accessible Air Valve**

Inspection or maintenance of every Yamada air valve may be performed without removing the pump from service.

**Unified Air Valve Concept**

Common-size air valve assemblies reduce parts confusion.

**Pilot Valve**

Unique to the Yamada design is an individual modular pilot valve that actuates the air valve. It is depressed slightly by the inner center disk creating a pressure drop at one end of the air valve, allowing shifting to occur. It is maintenance free with no cumbersome snap rings or lubricated dynamic o-rings to replace or repair.

**Optimal Stroke Length**

Extensive research has led to the development of an optimal stroke length that maximizes diaphragm life and performance while minimizing downtime and maintenance costs.



# Yamada® Patented Air Valve Technology

Yamada air valve technology is the heart of the air-powered double diaphragm pump and determines reliability. Yamada holds three patents on its field proven valve and enjoys a superior reputation throughout the industry.

## Unified Air Valve Concept

To simplify, Yamada offers two common size air valve assemblies within five sizes of pumps (3/4" & 1" pumps and 1-1/2", 2" & 3" pumps) further reducing reassembly confusion and parts inventory. Other air-powered double diaphragm pump manufacturers offer multiple air valve designs and revisions in an effort to address pump reliability problems. Multiple designs and revisions typically create maintenance rebuild issues, parts confusion, and obsolete inventory. *Whether your pumps are functioning continuously or intermittently—at high or low pressure—using dirty or clean air—Yamada offers one field proven design.*

## Truly Non-Lubricated Air Valve

The patented Yamada air valve on all NDP series pumps never requires lubrication or pre-packing. The advanced design eliminates the need for external lubrication, which can lead to pumpage contamination and maintenance headaches. *Yamada is proud to be the originator of non-lubricated air valve technology for air-powered double diaphragm pumps.*

Some air-powered double diaphragm pump manufacturers claim to offer a non-lubricated air valve. Dependent upon the competitor's design, the air valve will probably require lubrication for continuous operation, or lubricator installation if moisture is present within the air system. These valves are pre-packed with grease and are not truly non-lubricated.

## Component Replaceable

All Yamada air valves can be restored with individual components, without requiring complete valve and housing replacement.

Many competitor air valves incorporate a complicated design which requires complete replacement of the valve assembly and housing, further increasing the cost of ownership.

*Common-size air valve assemblies reduce parts confusion.*



↑ Air Valve fits NDP-20 (3/4") & NDP-25 Series (1")

← Air Valve fits NDP-40 (1-1/2"), NDP-50 (2"), & NDP-80 (3") Series Pumps

## Non-Stalling

A patented non-centering, spring-assisted shifter is incorporated into every NDP Series pump, ensuring a positive shift every time.

The 304 stainless steel C-springs provide exceptional durability and longevity and are tested to last over **300 million cycles!**

The spring assist also aides in long dead head applications for reliable startup.



## Advantages and Characteristics

- Handles a wide variety of fluids with high solids content:** No close fitting or rotating parts so liquid with high solids content and/or size can be easily pumped.
- Self Priming:** The Yamada pump design (incorporating internal check valves) allows for high suction lift even at dry start-up and with heavier fluids.
- Ability to run dry:** No close fittings or sliding parts are at risk—the pump can run dry without damage.
- Variable flow rate and discharge pressure:** Yamada pumps will run at any setting within their operating range simply by adjusting the air inlet pressure and system conditions. One pump can fit a broad spectrum of applications.
- Portable/Simple Installation:** Yamada pumps transport easily to the application site. Simply connect your air supply line and liquid lines; the pump is ready to perform. There are no complex controls to install and operate.
- Dead Head:** Because the discharge pressure can never exceed air inlet pressure, the discharge line can be closed with no damage or wear. The pump will simply slow down and stop.
- Shear sensitive:** The gentle nature and minimal parts contact with the liquid makes Yamada pumps an excellent choice for shear sensitive fluids.
- Explosion Proof:** Yamada pumps are operated by compressed air, therefore, they are intrinsically safe.
- Submersible:** If external components are compatible—Yamada pumps can be submerged in the liquid by simply running the exhaust line above the liquid level.
- Pumping efficiency remains constant:** There are no rotors, gears, or pistons, which wear over time and lead to the gradual decline in performance/flow rate.

For additional information on Yamada products and services, visit [yamadacorp.co.jp/global](http://yamadacorp.co.jp/global)

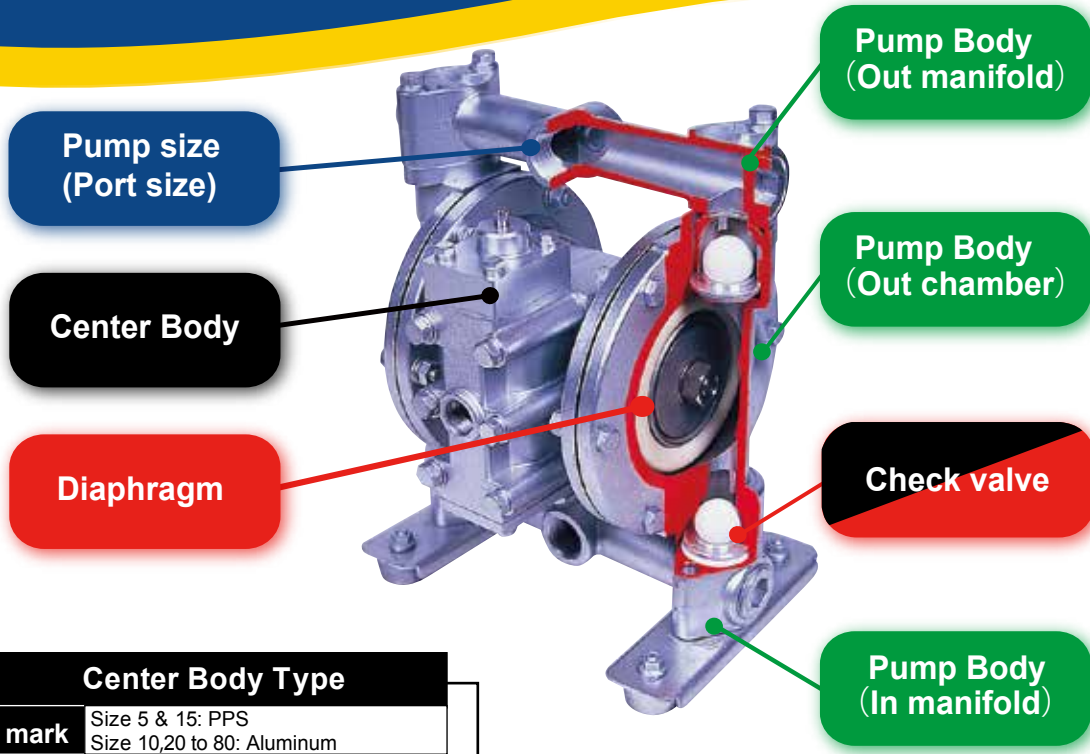
# Model Indicator

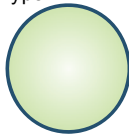

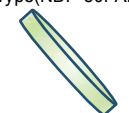
Check Valve	
B	Ball Type 
	Flat Type (PTFE for size 5&15) 
F	Flap Type (NDP-50FAN) 

Center Body Type	
No mark	Size 5 & 15: PPS Size 10,20 to 80: Aluminum
P	Polypropylene (Size 20 & 25)
H	Aluminum Mechanical Switch (Size 40, 50 & 80)

**NDP-**    **B**    

Pump Size	Port Type	Port Type	
		Rc thread / JIS flange	NPT thread / ANSI flange
5	Port size 1/4" (5mm)	Rc thread	NPT
10	Port size 3/8" (10mm)	Rc thread	NPT
15	Port size 1/2" (15mm)	Rc thread	NPT
20	Port size 3/4" (20mm)	Metal Body: Rc thread Plastic Body: JIS/DIN/ANSI flange, Rc thread	NPT
25	Port size 1" (25mm)	Metal Body: Rc thread Plastic Body: JIS/DIN flange, Rc thread	Metal Body: NPT Plastic Body: ANSI flange, NPT
32	Intake port size 1-1/2" (40mm), Discharge port size 1-1/4" (32mm)	Rc thread	NPT
40	Port size 1-1/2", (40mm)	JIS/DIN flange (Cast Iron Body: Rc thread)	ANSI flange (Cast Iron Body: NPT)
50	Port size 2", (50mm)	JIS/DIN/ANSI flange (Cast Iron Body: Rc thread)	Cast Iron Body: NPT
80	Port size 3", (80mm)	JIS/DIN/ANSI flange (Cast Iron Body: Rc thread)	Cast Iron Body: NPT

Pump Body Material	Liquid Temp Range	Characteristic
A Aluminum (ADC-12/AC4C-T6)	0 ~ 100°C	Good for oil and solvent. Not good for chemical, corrosive and abrasive
S Stainless Steel (SCS14/SUS316)	0 ~ 100°C	Hard and rust resistant. Good for corrosive and abrasive liquid
F Cast Iron (FC250/S45C)	0 ~ 100°C	Hard but easy to rust. Good for Iron oxide, sludge, etc.
P Polypropylene (PPG)	0 ~ 60°C	A tough flexible synthetic thermoplastic materials
V Kynar® (PVDF)	0 ~ 60°C	Good tensile and compressive strength and high impact strength
D Groundable Acetal (POM)	0 ~ 60°C	Excellent mechanical and high-temperature properties
T PTFE	0 ~ 100°C	A synthetic fluoropolymer of tetrafluoroethylene that that is characteristically resistant to heat, acid oxidizing agents and to alkalis

Diaphragm/Check Valve Material	Liquid Temp Range	Characteristic
C Neoprene (CR)	0 ~ 70°C	A tough, synthetic rubber that is resistant to the effects of oils, solvents, heat, and weather
N Buna N (NBR)	0 ~ 70°C	An oil-resistant synthetic rubber that is resistant to oil, fuel, and other chemicals
E EPDM	0 ~ 80°C	A type of synthetic rubber that is resistant to heat, ozone and weather, polar substances and steam
H Hytrel® (TPEE)	0 ~ 100°C	A thermoplastic polyester elastomer that gives the flexibility of rubbers, the strength of plastics, and the processibility of thermoplastics
S Santoprene® (TPO)	0 ~ 100°C	A flexible and durable elastomer that has environmental aging resistance, electrical properties
V Viton® (FKM)	0 ~ 100°C	A fluoropolymer elastomer that has oil, heat and chemical resistance
T PTFE	0 ~ 100°C	A synthetic fluoropolymer of tetrafluoroethylene that that is characteristically resistant to heat, acid oxidizing agents and to alkalis

# Fair Guideline of Pump size and Flow rate

Operation with the maximum cycle shorten the pump lifetime.

To optimize pump performance and lifetime, please select pump in reference to this guideline.

## Recommended Flow Rate by Pump Size

	L/min			
NDP-5	5		50	100
DP-10	10			
NDP-15		20		
NDP-20			60	
NDP-25			90	
NDP-40		200	250	500
NDP-50			320	
NDP-80			450	

## Using Performance Curves

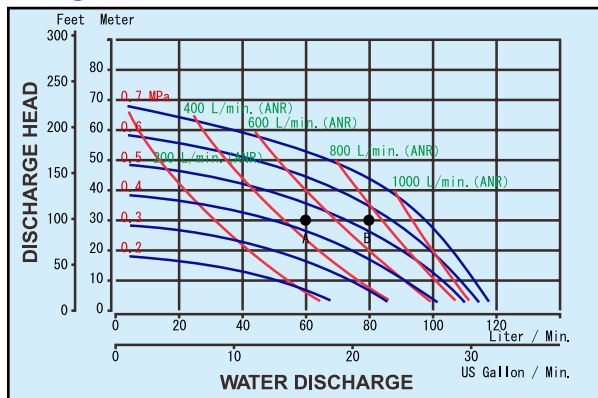

### Precautions for pump selection

\* Select a pump with safety margin (1.5 times or higher) appropriate for the required conditions with taking effective use of a diaphragm and other expendables into consideration.

\* The performance curve shown on the right indicates the data measured with fresh water (viscosity 1 mPa·s, specific gravity 1.0) by dip grazing with the shown devices. The amount of liquid discharged from the pump greatly varies depending on various factors such as the "viscosity, specific gravity and slurry concentration of liquid to be transferred," "suction lift," "discharge head" and "pneumatic transportation distance." If you are not sure which pump you should select, fill in the selection criterion of the "Inquiry Sheet" on the end of the document as much as possible, and contact us.

1. The solid lines plot the relation between the amount of the discharged liquid ("water discharge") and the discharge head when the corresponding pressure is given. First, decide which curve corresponds to the desired air pressure.
2. For example, when the supplied air pressure at your site is 0.5 MPa, check the curve marked "0.5 MPa."
3. When liquid to be transferred is fresh water (viscosity is 1 mPa·s and specific gravity is 1.0), the desired water discharge is 60 L/min, and the discharge head is 30 m, the corresponding axes intersect at Point A. This point is located below the 0.5-Mpa curve and satisfies the desired water discharge and discharge head with this pump (Example: NDP-20).
4. If it is required that "the water discharge is 80 L/min, and the discharge head is 30 m," the intersection point is "B" above the 0.5-MPa curve and this indicates that this pump cannot satisfy your conditions. In such a case, we recommend that you select the larger one (NDP-25).

## Specified Suction Lift

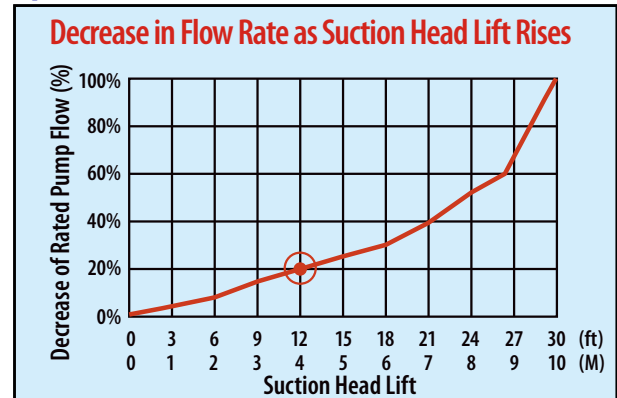

With a suction lift of 12-ft, 4m pump rate decreases by approximately 20%. Valid for pumps 3/4" and larger; data varies with pump configuration.

## Viscous Liquids Performance Data

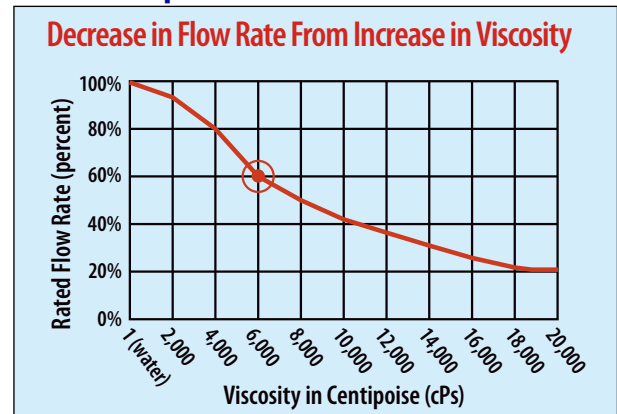

During the conveyance of a fluid with a viscosity of 6000 cPs, the pump rate decreases to 60% of its rated value (100% = water). Valid for 3/4" pumps & larger. Note: Please consult Yamada when both the pressure and temperature exceed 70 MPa and 180°C, respectively.

5. The dashed lines plot curves for air consumption as shown in the graph respectively. The point A, intersection point as a result of the condition "3." above (water discharge: 60 L/min, discharge head: 30 m) is located about in the middle between the 400L/min air consumption curve and the 600L/min air consumption curve. Therefore, the air consumption under this condition is approximately 500 L/min (ANR). Since the air consumption is calculated by converting to the barometric pressure, it does not vary depending on the used air pressure.

# NDP-5 Series

11L/min Maximum Flow Rate  
1/4 inch Port Size

## Specifications

Port Size		1/4" (6A)
Liquid	Intake	Rc1/4" or NPT1/4"
	Discharge	Rc1/4" or NPT1/4"
Air	Supply	Rc1/4" or NPT1/4" includes ball valve
	Exhaust	Rc3/8" or NPT3/8" w/ internal silencer*
Air Supply Pressure		0.2 - 0.7 MPa
Maximum Discharge Pressure		0.7 MPa

\*Silencer is internal type. Exhaust port has Rc3/8" or NPT3/8" thread.

Discharge Volume Per Cycle	20mL
Maximum Size Solid	N/A
Net Weight	NDP-5FAT: 1.6kg
	NDP-5FST: 2.7kg
	NDP-5FPT: 1.3kg
	NDP-5FVT: 1.7kg
NDP-5FDT: 1.4kg	

## Metal Body Pumps



NDP-5FAT

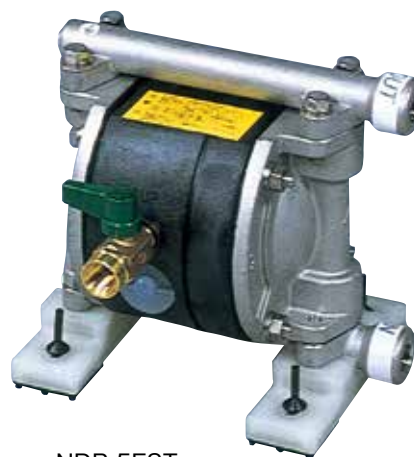

NDP-5FST

## Model Chart

Body Material	Connection Liquid/Air	Diaphragm Material
		PTFE
Aluminum (ADC 12)	Rc/Rc	NDP-5FAT (851496) (851564)
	NPT/NPT	NDP-5FST (851497) (851565)
Stainless Steel (SCS14/SUS316)	Rc/Rc	NDP-5FAT (851496) (851564)
	NPT/NPT	NDP-5FST (851497) (851565)

## Dimensions

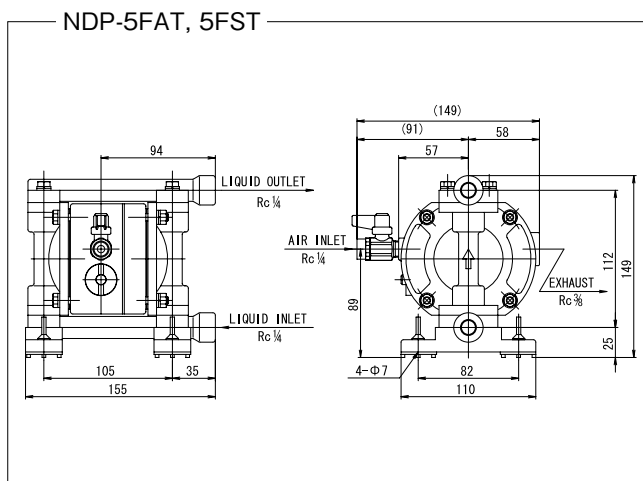

## Performance Curve

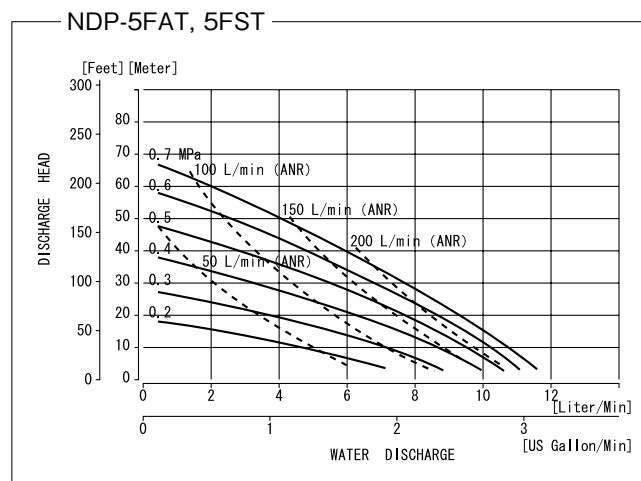

# Body Materials

Models	NDP-5FAT	NDP-5FST	NDP-5FPT	NDP-5FVT	NDP-5FDT
Check Valve	PTFE Flat Type				
Valve Seat	SUS316	SUS316	PPG	PVDF	POM
Valve Guide	SUS316	SUS316	PPG	PVDF	POM
Center Disk	A5056	SUS316	PPG (SUS304*)	PVDF (SUS304*)	POM (SUS304*)

\*Material of the insert

- ✓ Flat type check valve is not suitable for slurry handling
- ✓ Maximum Dry Suction Lift is 1M

## Plastic Body Pumps



Air supply pressure of Plastic Body Pumps is depending on the liquid temperature. Be sure to check the Liquid temperature – Pressure Correlation Chart.



NDP-5FPT



NDP-5FDT



NDP-5FVT

### Model Chart

Body Material	Connection Liquid/Air	Diaphragm Material
		PTFE
Polypropylene (PPG)	Rc/Rc	NDP-5FPT (851306)
	NPT/NPT	(851562)
Kynar® (PVDF)	Rc/Rc	NDP-5FVT (852110)
	NPT/NPT	(852064)
Groundable Acetal (POM)	Rc/Rc	NDP-5FDT (853779)
	NPT/NPT	(853781)



\* Purchaser shall not directly or indirectly, export, re-export transship or otherwise transfer this product in violation of any applicable export control laws and regulations promulgated and administered by the governments of the countries asserting jurisdiction over the parties or transaction.

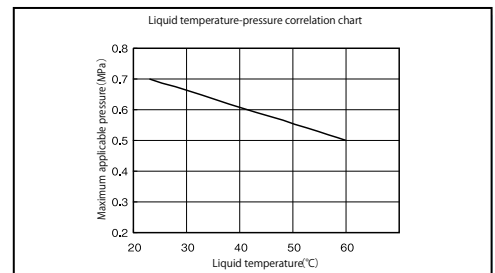

### Dimensions

NDP-5FPT, 5FVT, 5FDT

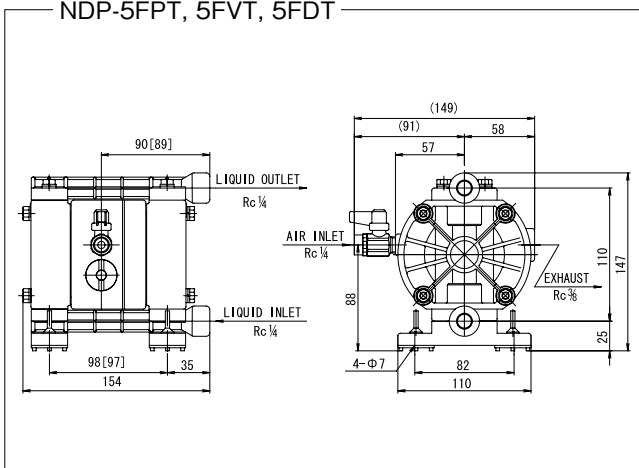

### Performance Curve

NDP-5FPT, 5FVT, 5FDT

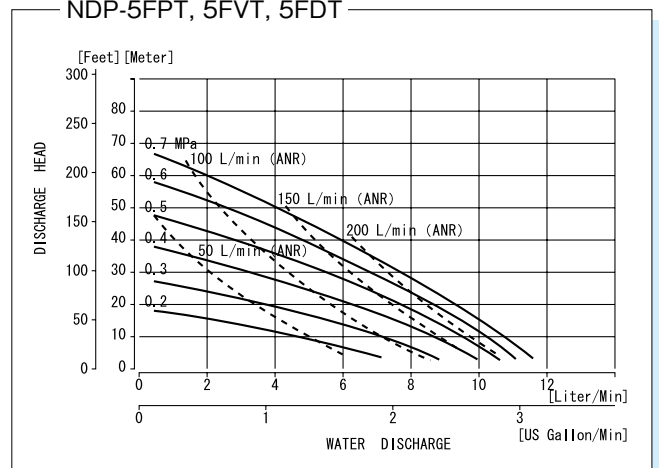

# DP-10 Series

20L/min Maximum Flow Rate  
3/8 inch Port Size

## Specifications

Port Size		3/8" (10A)
Liquid	Intake	Rc3/8" or NPT3/8"
	Discharge	Rc3/8" or NPT3/8"
Air	Supply	Rc1/4" or NPT1/4" includes ball valve
	Exhaust	Rc3/8" or NPT3/8" w/ silencer
Air Supply Pressure		0.2 - 0.7 MPa
Maximum Discharge Pressure		0.7 MPa

Discharge Volume Per Cycle	50mL
Maximum Size Solid	1mm
Net Weight	DP-10BA □: 3.5kg
	DP-10BS □: 5.2kg
	DP-10BP □: 3.0kg

## Metal Body Pumps

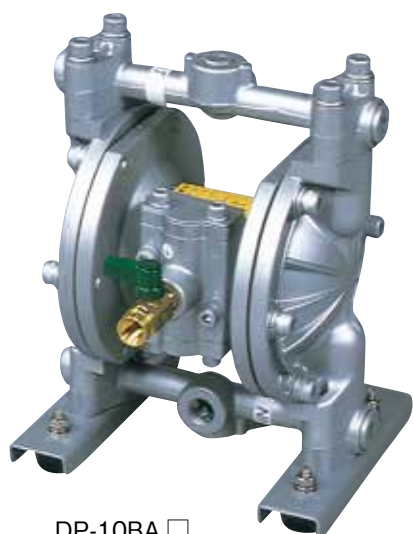

DP-10BA □



DP-10BS □

## Model Chart

Body Material	Connection Liquid/Air	Diaphragm Material					
		Neoprene (CR)	Buna N (NBR)	PTFE	Hytrel® (TPEE)	Hytrel® (TPEE)	Santoprene® (TPO)
Aluminum (ADC12)	Rc/Rc NPT/NPT	DP-10BAC (851743) (851842)	DP-10BAN (851742) (851841)	DP-10BAT (851725) (851839)	DP-10BAH (851750) (851847)	DP-10BAH/T (851872) (-----)	DP-10BAS (852674) (852677)
		DP-10BSC (851746) (851845)	DP-10BSN (851747) (851846)	DP-10BST (851741) (851840)	DP-10BSH (851751) (851848)	DP-10BSH/T (851873) (-----)	DP-10BSS (852675) (852678)

## Dimensions

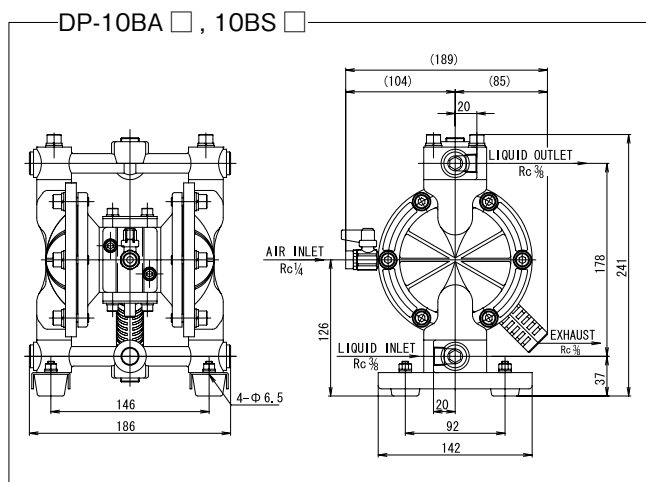

## Performance Curve

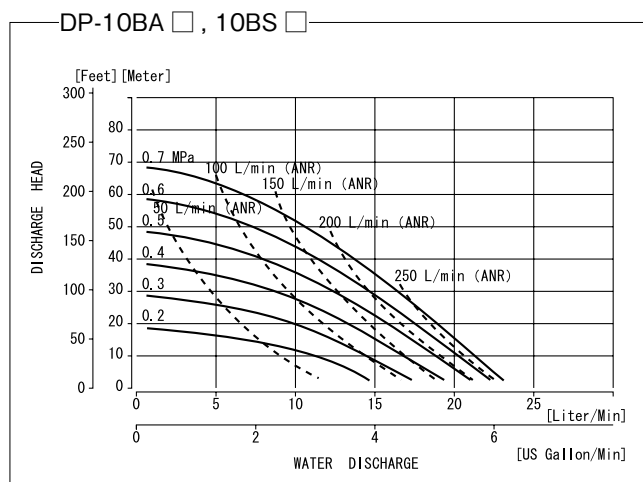



# Body Materials

Models	DP-10BA□	DP-10BS□	DP-10BPN	DP-10BPC	DP-10BP□
Check Valve	Same material as the diaphragm (PTFE for B□H/T models)				
Valve Seat	A5056	SUS316	NBR	CR	PPG
Valve Guide	PA	SUS316	PPG		
Center Disk	A5056	SUS316	PPG (SUS304*)		

\* Material of the insert

**!** PA (nylon) is used for the Valve Guide of DP-10BA□. Please be aware of corrosion resistant.

✓ Maximum Dry Suction Lift is 1M

## Plastic Body Pumps



Air supply pressure of Plastic Body Pumps is depending on the liquid temperature. Be sure to check the Liquid temperature – Pressure Correlation Chart.



DP-10BP □

### Model Chart

Body Material	Connection Liquid/Air	Diaphragm Material					
		Neoprene (CR)	Buna N (NBR)	PTFE	Hytre <sup>®</sup> (TPEE)	Hytre <sup>®</sup> (TPEE)	Santoprene <sup>®</sup> (TPO)
Polypropylene (PPG)	Rc/Rc	DP-10BPC (851745)	DP-10BPN (852280)	DP-10BPT (851744)	DP-10BPH (851752)	DP-10BPH/T (851874)	DP-10BPS (852676)
	NPT/NPT	(851844)	(852388)	(851843)	(851849)	(.....)	(852679)

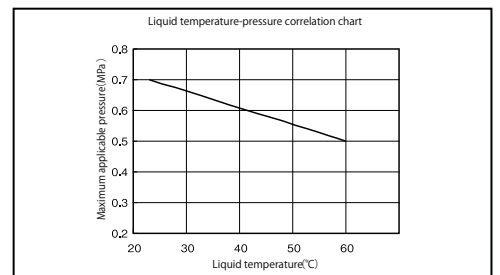

### Dimensions

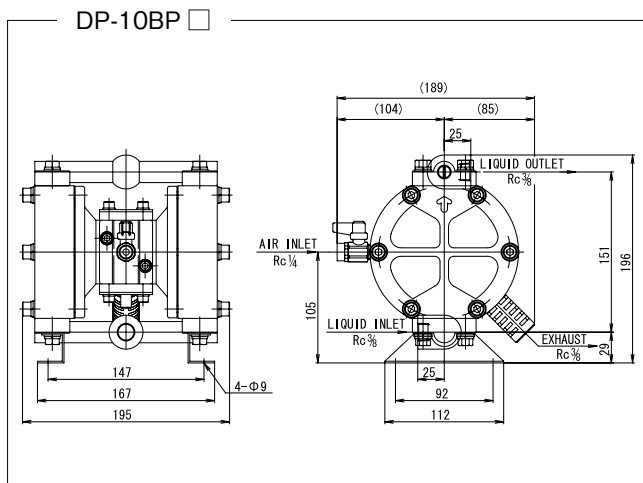

### Performance Curve

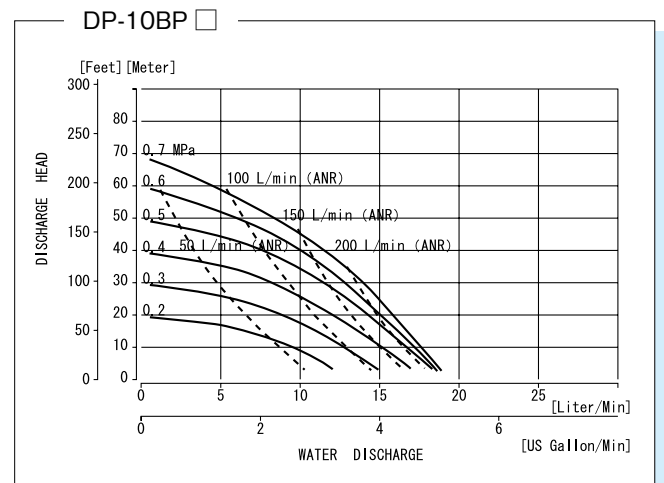

# NDP-15 Series

50L/min Maximum Flow Rate  
1/2 inch Port Size

## Specifications

Port Size		1/2" (15A)
Liquid	Intake	Rc1/2" or NPT1/2"
	Discharge	Rc1/2" or NPT1/2"
Air	Supply	Rc1/4" or NPT1/4" includes ball valve
	Exhaust	Rc3/8" or NPT3/8" w/ internal silencer*
Air Supply Pressure		0.2 - 0.7 MPa
Maximum Discharge Pressure		0.7 MPa

Discharge Volume Per Cycle	70mL
Maximum Size Solid	1mm
Net Weight	NDP-15BA□: 4.1kg
	NDP-15BS□: 6.3kg
	NDP-15FP□: 3.5kg
	NDP-15FVT: 4.3kg
	NDP-15FDT: 3.5kg

\*Silencer is internal type. Exhaust port has Rc3/8" or NPT3/8" thread.

**!** NDP-15 is fitted with the same sized diaphragm as DP-10 series.  
Please select NDP-20 series in case of the application exceeding 20L/min of flow rate.

## Metal Body Pumps



NDP-15BA □



NDP-15BS □

## Model Chart

Body Material	Connection Liquid/Air	Diaphragm Material					
		Neoprene (CR)	Buna N (NBR)	PTFE	Hytre <sup>®</sup> (TPEE)	Hytre <sup>®</sup> (TPEE)	Santoprene <sup>®</sup> (TPO)
Aluminum (ADC12)	Rc/Rc	NDP-15BAC (851946)	NDP-15BAN (851947)	NDP-15BAT (851945)	NDP-15BAH (851948)	NDP-15BAH/T (853022)	NDP-15BAS (852680)
	NPT/NPT	(851950)	(851951)	(851949)	(851952)	(-----)	(852685)
Stainless Steel (SCS14/SUS316)	Rc/Rc	NDP-15BSC (851958)	NDP-15BSN (851959)	NDP-15BST (851957)	NDP-15BSH (851960)	-----	NDP-15BSS (852675)
	NPT/NPT	(851962)	(851963)	(851961)	(851964)		(852686)

## Dimensions

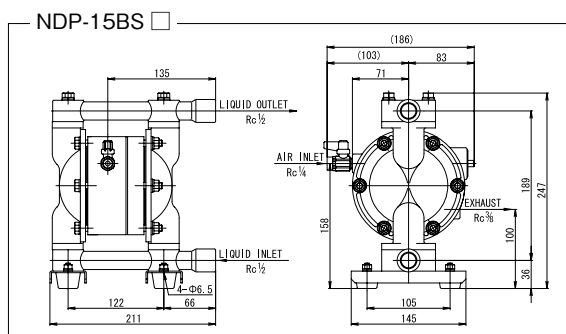
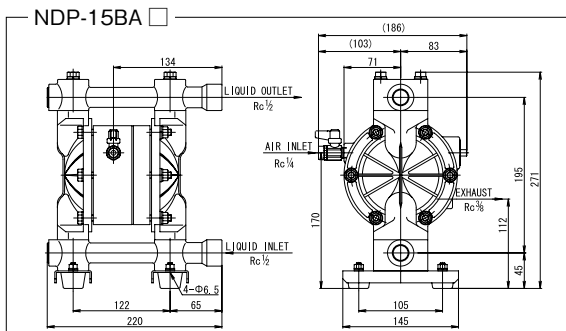

## Performance Curve

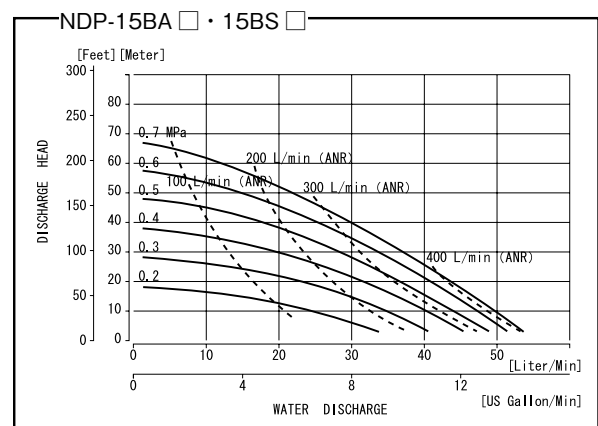

# Body Materials

Models	NDP-15BA□	NDP-15BS□	NDP-15FP□,BP□	NDP-15FVT	NDP-15FDT
Check Valve	Metal Body Pumps: Same material as the diaphragm (PTFE for B□H/T models) Plastic Body Pumps: PTFE Flat type for FP□, FVT and FDT PTFE Ball type for BP□				
Valve Seat	A5056	SUS316	PPG	PVDF	POM
Valve Guide	PA	SUS316	PPG	PVDF	POM
Center Disk	A5056	SUS316	PPG(SUS304*)	PVDF (SUS304*)	POM

\* Material of the insert



PA (nylon) is used for the Valve Guide of NDP-15BA□. Please be aware of corrosion resistant.

- ✓ Flat type check valve is not suitable for slurry handling
- ✓ Maximum Dry Suction Lift is 1M

## Plastic Body Pumps



Air supply pressure of Plastic Body Pumps is depending on the liquid temperature. Be sure to check the Liquid temperature - Pressure Correlation Chart.



NDP-15FP □ ,BP □



NDP-15FVT



NDP-15FDT

### Model Chart

	Body Material	Connection Liquid/Air	Diaphragm Material				
			Neoprene (CR)	Buna N (NBR)	PTFE	Hytrel® (TPEE)	Santoprene® (TPO)
Flat Check	Polypropylene (PPG)	Rc/Rc NPT/NPT	NDP-15FPC (851903) (851904)	NDP-15FPN (851943) (851944)	NDP-15FPT (851698) (851699)	NDP-15FPH (851905) (851906)	NDP-15FPS (852683) (852688)
	Kynar® (PVDF)	Rc/Rc NPT/NPT	-----	-----	NDP-15FVT* (852141) (852103)	-----	-----
	Groundable Acetal (POM)	Rc/Rc NPT/NPT	-----	-----	NDP-15FDT (853780) (853782)	-----	-----
Ball Check	Polypropylene (PPG)	Rc/Rc NPT/NPT	NDP-15BPC (852351) (852348)	-----	NDP-15BPT (852352) (852349)	NDP-15BPH (852353) (852350)	-----



\* Purchaser shall not directly or indirectly export, re-export transship or otherwise transfer this product in violation of any applicable export control laws and regulations promulgated and administered by the governments of the countries asserting jurisdiction over the parties or transaction.

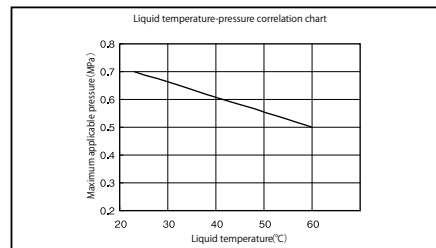

### Dimensions

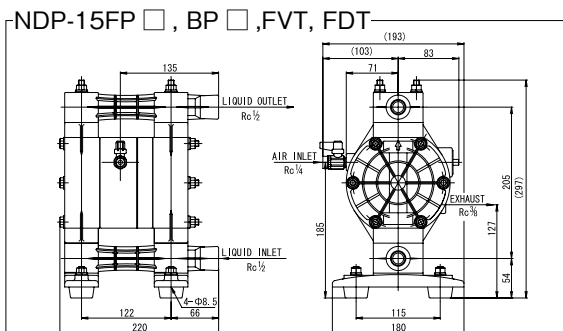

### Performance Curve

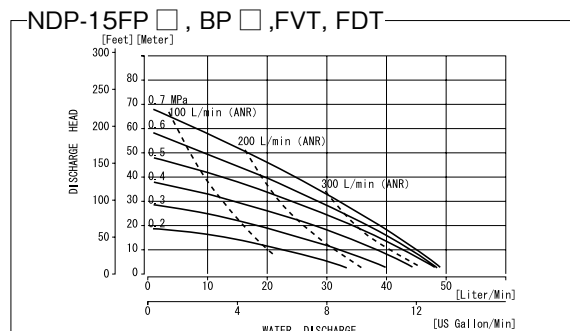

# NDP-20 Series

110L/min Maximum Flow Rate  
3/4 inch Port Size

## Specifications

Port Size		3/4" (20A)
Liquid	Intake	Metal Body: Rc3/4" or NPT3/4" Plastic Body: JIS/DIN/ANSI Compatible Flange, Rc3/4" or NPT3/4" (JIS10K20A for P20BTT)
	Discharge	Metal Body: Rc3/4" or NPT3/4" Plastic Body: JIS/DIN/ANSI Compatible Flange, Rc3/4" or NPT3/4" (JIS10K20A for P20BTT)
Air	Supply	Rc1/4" or NPT1/4" includes ball valve
	Exhaust	Rc3/4" or NPT3/4" w/ silencer
Air Supply Pressure		0.2-0.7MPa (0.2-0.5MPa for P20BTT)
Maximum Discharge Pressure		0.7MPa (0.5MPa for P20BTT)

Discharge Volume Per Cycle	Rubber diaphragm: 350mL PTFE diaphragm: 240mL	
Maximum Size Solid	2mm	
Net Weight	NDP-20BA□	NDP-P20BA□: 7.5kg
	NDP-20BS□	NDP-P20BS□: 12.5kg
	NDP-20BP□	NDP-P20BP□: 7.0kg
		NDP-P20BT: 20.0kg

## Metal Body Pumps



Model Chart

NDP-20BA □

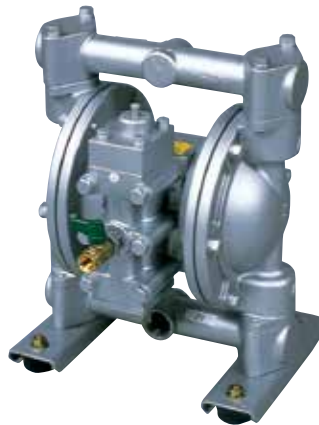

NDP-20BS □



NDP-P20BA □

## Model Chart

	Body Material	Connection Liquid/Air	Diaphragm Material							
			Neoprene (CR)	Buna N (NBR)	EPDM	Viton® (FKM)	PTFE	Hytre® (TPEE)	Hytre® (TPEE)	Santoprene® (TPO)
Aluminum Center Body	Aluminum (ADC12)	Rc/Rc NPT/NPT	NDP-20BAC (851316) (851514)	NDP-20BAN (851317) (851515)	NDP-20BAE (851318) (851516)	NDP-20BAV (851319) (851517)	NDP-20BAT (851320) (851518)	NDP-20BAH (851729) (852098)	NDP-20BAH/T (851875) (-----)	NDP-20BAS (852690) (852693)
	Stainless Steel (SCS14/SUS316)	Rc/Rc NPT/NPT	NDP-20BSC (851321) (851519)	NDP-20BSN (851322) (851520)	NDP-20BSE (851323) (851521)	NDP-20BSV (851324) (851522)	NDP-20BST (851325) (851523)	NDP-20BSH (851730) (852099)	NDP-20BSH/T (851876) (-----)	NDP-20BSS (852691) (852694)
Polypropylene Center Body	Aluminum (ADC12)	Rc/Rc NPT/NPT	NDP-P20BAC (854052) (854059)	NDP-P20BAN (854053) (854060)	NDP-P20BAE (854054) (854061)	NDP-P20BAV (854055) (854062)	NDP-P20BAT (854056) (854063)	NDP-P20BAH (854057) (854064)	NDP-P20BAH/T (854213) (-----)	NDP-P20BAS (854058) (854065)
	Stainless Steel (SCS14/SUS316)	Rc/Rc NPT/NPT	NDP-P20BSC (854066) (854073)	NDP-P20BSN (854067) (854074)	NDP-P20BSE (854068) (854075)	NDP-P20BSV (854069) (854076)	NDP-P20BST (854070) (854077)	NDP-P20BSH (854071) (854078)	NDP-P20BSH/T (854214) (-----)	NDP-P20BSS (854072) (854079)

## Dimensions

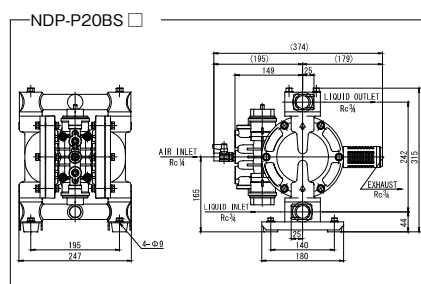
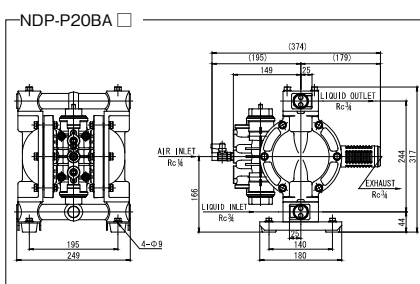
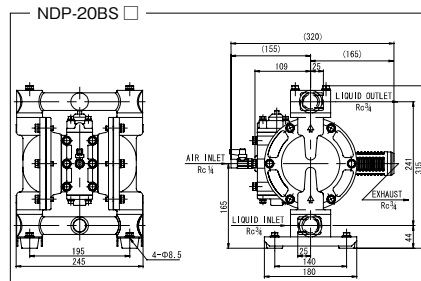
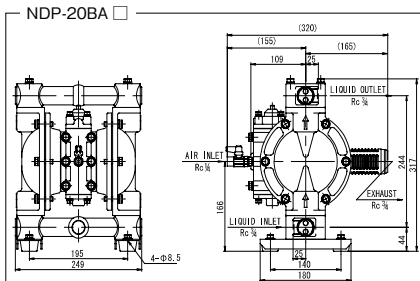

## Performance Curve

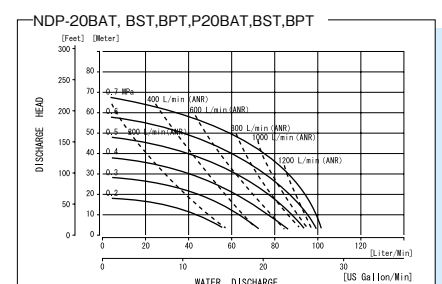
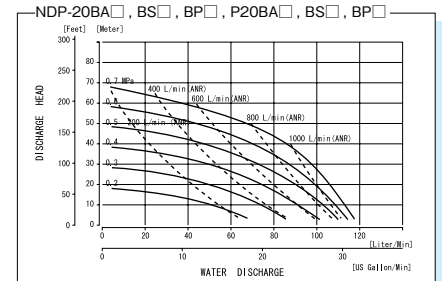

# Body Materials

Models	NDP-20BA□, NDP-P20BA□	NDP-20BS□, NDP-P20BS□	NDP-20BP□, NDP-P20BP□	NDP-P20BTT
Check Valve	Same material as the diaphragm (PTFE for B□H/T models)			
Valve Seat	SMS1025	SUS316	PPG	PTFE
Valve Guide	A5056	SCS14	PPG	PTFE
Center Disk	BA□:SUS316 BAT:A5056	SUS316	PPG (SCS13*)	PFA (SUS316*)

\* Material of the insert

✓ Maximum Dry Suction Lift is 3M for Rubber Diaphragm and 1.5M for PTFE Diaphragm.

## Plastic Body Pumps



Air supply pressure of Plastic Body Pumps is depending on the liquid temperature. Be sure to check the Liquid temperature - Pressure Correlation Chart.



NDP-P20BP □ Flange



NDP-P20BTT

### Model Chart

	Body Material	Connection Liquid/Air	Diaphragm Material								
			Neoprene (CR)	Buna N (NBR)	EPDM	Viton <sup>®</sup> (FKM)	PTFE	Hytrel <sup>®</sup> (TPEE)	Hytrel <sup>®</sup> (TPEE)	Santoprene <sup>®</sup> (TPO)	
Polypropylene Center Body	JIS/DIN/ANSI Compatible Flange	Polypropylene (PPG)	Flange/Rc Flange/NPT	NDP-P20BPC (854101) (854108)	NDP-P20BPN (854102) (854109)	NDP-P20BPE (854103) (854110)	NDP-P20BPV (854104) (854111)	NDP-P20BPT (854105) (854112)	NDP-P20BPH (854106) (854113)	NDP-P20BPH/T (854216) (-----)	NDP-P20BPS (854107) (854114)
	JIS Flange	PTFE	Flange/Rc	-----	-----	-----	-----	NDP-P20BTT (854323)	-----	-----	-----
Aluminum Center Body	JIS/DIN/ANSI Compatible Flange	Polypropylene (PPG)	Flange/Rc Flange/NPT	NDP-20BPC (853819) (853828)	NDP-20BPN (853820) (853829)	NDP-20BPE (853821) (853830)	NDP-20BPV (853822) (853831)	NDP-20BPT (853823) (853832)	NDP-20BPH (853824) (853833)	NDP-20BPH/T (853826) (-----)	NDP-20BPS (853825) (853834)
	Thread	Polypropylene (PPG)	Rc/Rc NPT/NPT	NDP-20BPC (851663) (851665)	NDP-20BPN (852596) (852382)	NDP-20BPE (852407) (852383)	NDP-20BPV (852597) (852384)	NDP-20BPT (851664) (851666)	NDP-20BPH (851734) (852069)	NDP-20BPH/T (851877) (-----)	NDP-20BPS (852692) (852695)



\* Purchaser shall not directly or indirectly, export, re-export transship or otherwise transfer this product in violation of any applicable export control laws and regulations promulgated and administered by the governments of the countries asserting jurisdiction over the parties or transaction.

### Dimensions

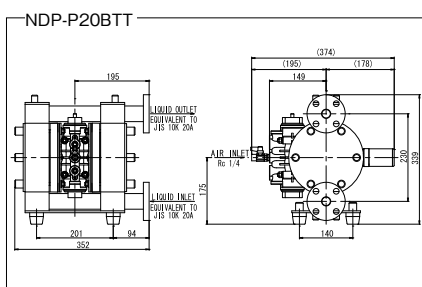
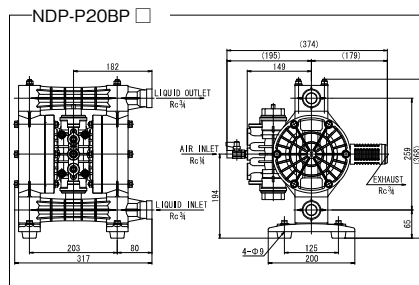
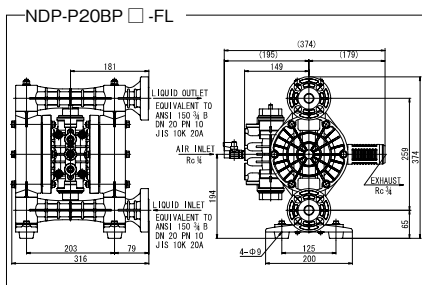

### Performance Curve

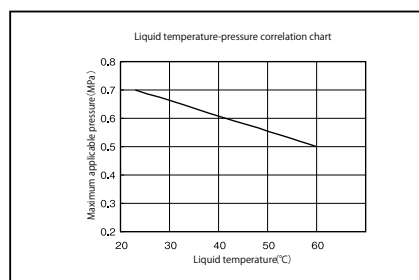
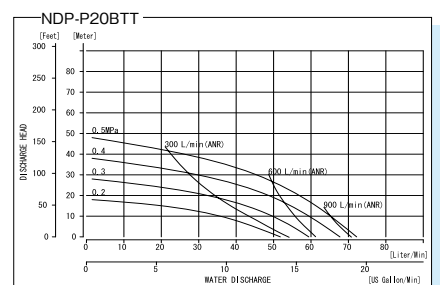

# NDP-25 Series

160L/min Maximum Flow Rate  
1 inch Port Size

## Specifications

Port Size		1" (25A)
Liquid	Intake	Metal Body: Rc1" or NPT1" Plastic Body: JIS/DIN Compatible Flange, ANSI Flange, Rc1" or NPT1" (JIS10K25A for P25BTT)
	Discharge	Metal Body: Rc1" or NPT1" Plastic Body: JIS/DIN Compatible Flange, ANSI Flange, Rc1" or NPT1" (JIS10K25A for P25BTT)
Air	Supply	Rc3/8" or NPT3/8" includes ball valve
	Exhaust	Rc3/4" or NPT3/4" w/ silencer
Air Supply Pressure		0.2 - 0.7MPa (0.2-0.5MPa for P25BTT)
Maximum Discharge Pressure		0.7 MPa (0.5MPa for P25BTT)

Discharge Volume Per Cycle	Rubber diaphragm: 600mL PTFE diaphragm: 500mL
Maximum Size Solid	3mm
Net Weight	NDP-25BA □: 13.0kg    NDP-P25BA □: 11.0kg
	NDP-25BS □: 20.0kg    NDP-P25BS □: 18.0kg
	NDP-25BF □: 20.0kg    NDP-P25BP □: 9.5kg
	NDP-25BP □: 11.0kg    NDP-P25BV □: 12.0kg
	NDP-25BV □: 13.5kg    NDP-P25BTT: 33.0kg

## Metal Body Pumps



NDP-25BA □



NDP-25BS □



NDP-25BF □



NDP-P25BA □ NDP-P25BS □

## Model Chart

	Body Material	Connection Liquid/Air	Diaphragm Material							
			Neoprene (CR)	Buna N (NBR)	EPDM	Viton® (FKM)	PTFE	Hytre® (TPEE)	Hytre® (TPEE)	Santoprene® (TPO)
Aluminum Center Body	Aluminum (ADC12)	Rc/Rc NPT/NPT	NDP-25BAC (851328) (851527)	NDP-25BAN (851329) (851528)	NDP-25BAE (851330) (851529)	NDP-25BAV (851331) (851530)	NDP-25BAT (851332) (851531)	NDP-25BAH (851731) (852100)	NDP-25BAH/T (851878) (-----)	NDP-25BAS (852696) (852701)
	Stainless Steel (SCS14/SUS316)	Rc/Rc NPT/NPT	NDP-25BSC (851338) (851537)	NDP-25BSN (851339) (851538)	NDP-25BSE (851340) (851539)	NDP-25BSV (851341) (851540)	NDP-25BST (851342) (851541)	NDP-25BSH (851733) (852102)	NDP-25BSH/T (851879) (-----)	NDP-25BSS (852698) (852703)
	Cast Iron (S45C)	Rc/Rc NPT/NPT	NDP-25BFC (851333) (851532)	NDP-25BFN (851334) (851533)	NDP-25BFE (851335) (851534)	NDP-25BFV (851336) (851535)	NDP-25BFT (851337) (851536)	NDP-25BFH (851732) (852101)	NDP-25BFH/T (851880) (-----)	NDP-25BFS (852697) (852702)
Polypropylene Center Body	Aluminum (ADC12)	Rc/Rc NPT/NPT	NDP-P25BAC (854115) (854122)	NDP-P25BAN (854116) (854123)	NDP-P25BAE (854117) (854124)	NDP-P25BAV (854118) (854125)	NDP-P25BAT (854119) (854126)	NDP-P25BAH (854120) (854217)	NDP-P25BAH/T (854217) (-----)	NDP-P25BAS (854121) (854128)
	Stainless Steel (SCS14/SUS316)	Rc/Rc NPT/NPT	NDP-P25BSC (854129) (854136)	NDP-P25BSN (854130) (854137)	NDP-P25BSE (854131) (854138)	NDP-P25BSV (854132) (854139)	NDP-P25BST (854133) (854140)	NDP-P25BSH (854134) (854141)	NDP-P25BSH/T (854218) (-----)	NDP-P25BSS (854135) (854142)

## Dimensions

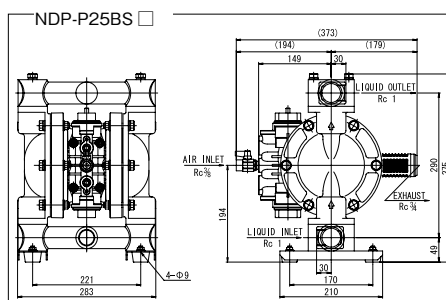
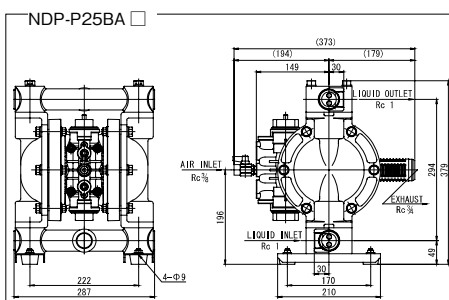
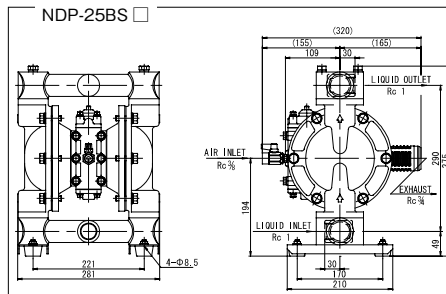
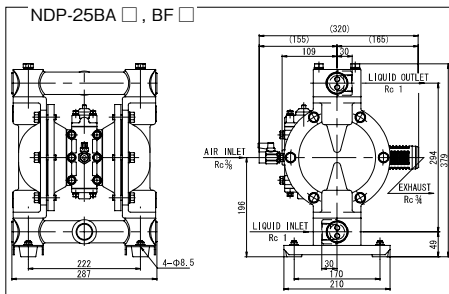

## Performance Curve

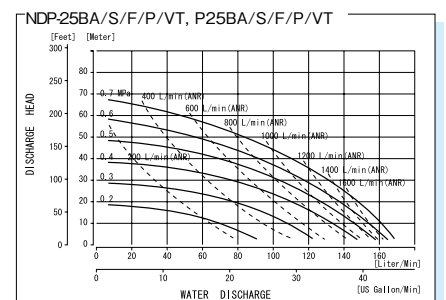
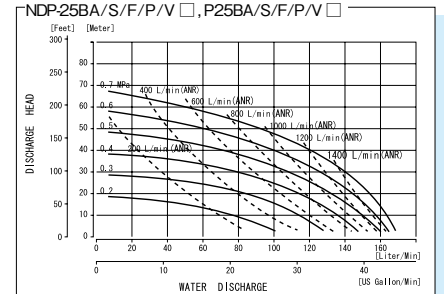

# Body Materials

Models	NDP-25BA□, NDP-P25BA□	NDP-25BS□, NDP-P25BS□	NDP-25BF□	NDP-25BP□, NDP-P25BP□	NDP-25BV□, NDP-P25BV□	NDP-P25BTT
Check Valve	Same material as the diaphragm (PTFE for B□/H/T models)					
Valve Seat	SMS1025	SUS316	SMS1025	PPG	PVDF	PTFE
Valve Guide	A5056	SCS14	SCS14	PPG	PVDF	PTFE
Center Disk	A5056	SUS316	SUS316	PPG (SCS13*)	PVDF (SCS13*)	PFA (SUS316*)

\* Material of the insert

✓ Maximum Dry Suction Lift is 5M for Rubber Diaphragm and 2M for PTFE Diaphragm

## Plastic Body Pumps (Polypropylene Center Body)



Air supply pressure of Plastic Body Pumps is depending on the liquid temperature. Be sure to check the Liquid temperature - Pressure Correlation Chart.



NDP-P25BP □ Flange



NDP-P25BV □ Flange



NDP-P25BTT

### Model Chart

	Body Material	Connection Liquid/Air	Diaphragm Material							
			Neoprene (CR)	Buna N (NBR)	EPDM	Viton® (FKM)	PTFE	Hytrek® (TPEE)	Hytrek® (TPEE)	Santoprene® (TPO)
Flange Connection	Polypropylene (PPG)	JIS-DIN/Rc ANSI/NPT	NDP-P25BPC (854178) (854185)	NDP-P25BPN (854179) (854186)	NDP-P25BPE (854180) (854187)	NDP-P25BPV (854181) (854188)	NDP-P25BPT (854182) (854189)	NDP-P25BPH (854183) (854190)	NDP-P25BPH/T (854221) (.....)	NDP-P25BPS (854184) (854191)
	Kynar® (PVDF)	JIS-DIN/Rc ANSI/NPT	-----	-----	NDP-P25BVE* (854201) (854204)	NDP-P25BVV* (854202) (854205)	NDP-P25BVT* (854203) (854206)	NDP-P25BVH* (854224) (854225)	-----	-----
	PTFE	JIS/Rc	-----	-----	-----	-----	NDP-P25BTT* (854618)	-----	-----	-----
Thread Connection	Polypropylene (PPG)	Rc/Rc NPT/NPT	NDP-P25BPC (854157) (854171)	NDP-P25BPN (854158) (854172)	NDP-P25BPE (854159) (854173)	NDP-P25BPV (854160) (854174)	NDP-P25BPT (854161) (854175)	NDP-P25BPH (854162) (854176)	NDP-P25BPH/T (854220) (.....)	NDP-P25BPS (854163) (854177)
	Kynar® (PVDF)	Rc/Rc NPT/NPT	-----	-----	NDP-P25BVE* (854192) (854198)	NDP-P25BVV* (854193) (854199)	NDP-P25BVT* (854194) (854200)	NDP-P25BVH* (854222) (854223)	-----	-----

⚠ \* Purchaser shall not directly or indirectly export, re-export transship or otherwise transfer this product in violation of any applicable export control laws and regulations promulgated and administered by the governments of the countries asserting jurisdiction over the parties or transaction.

### Dimensions

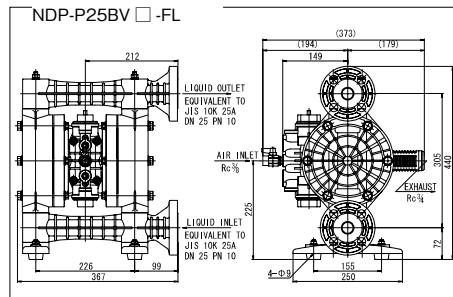
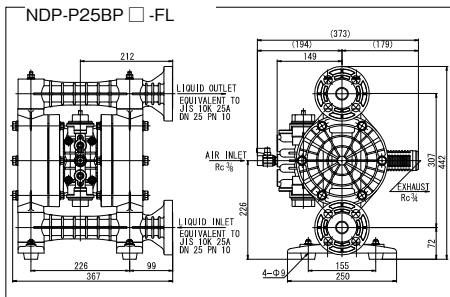

### Performance Curve

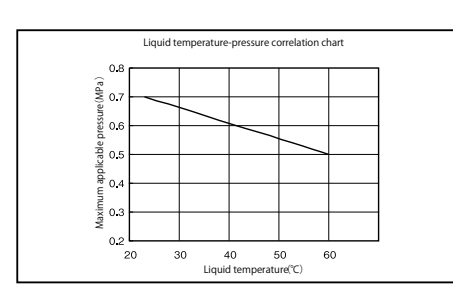
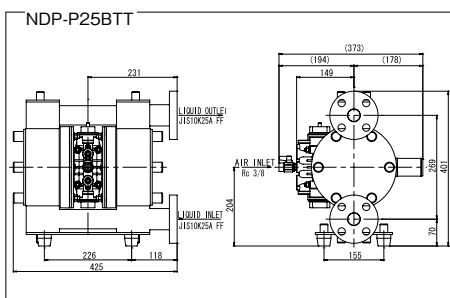
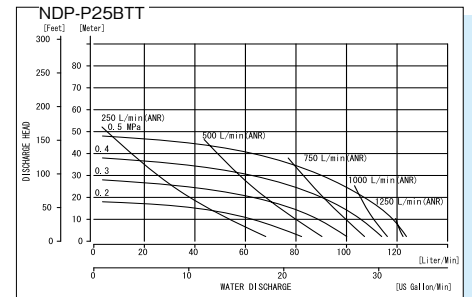

# Body Materials

Models	NDP-25BP□	NDP-25BV□
Check Valve	Same material as the diaphragm (PTFE for B□H/T models)	
Valve Seat	PPG	PVDF
Valve Guide	PPG	PVDF
Center Disk	PPG (SCS13*)	PVDF (SCS13*)

\* Material of the insert

✓ Maximum Dry Suction Lift is 5M for Rubber Diaphragm and 2M for PTFE Diaphragm

## Plastic Body Pumps (Aluminum Center Body)



Air supply pressure of Plastic Body Pumps is depending on the liquid temperature. Be sure to check the Liquid temperature - Pressure Correlation Chart.



NDP-25BP □ Flange



NDP-25BP □



NDP-25BV □ Flange



NDP-25BV □

### Model Chart

	Body Material	Connection Liquid/Air	Diaphragm Material							
			Neoprene (CR)	Buna N (NBR)	EPDM	Viton <sup>®</sup> (FKM)	PTFE	Hytel <sup>®</sup> (TPEE)	Hytel <sup>®</sup> (TPEE)	Santoprene <sup>®</sup> (TPO)
Flange Connection	Polypropylene (PPG)	JIS-DIN/Rc ANSI/NPT	NDP-25BPC (853835) (853844)	NDP-25BPN (853836) (853845)	NDP-25BPE (853837) (853846)	NDP-25BPV (853838) (853847)	NDP-25BPT (853839) (853848)	NDP-25BPH (853840) (853849)	NDP-25BPH/T (853842) (-----)	NDP-25BPS (853841) (854350)
	Kynar <sup>®</sup> (PVDF)	JIS-DIN/Rc ANSI/NPT	-----	-----	NDP-25BVE* (853851) (853856)	NDP-25BVV* (854852) (853857)	NDP-25BVT* (853853) (853858)	NDP-25BVE* (853854) (853859)	-----	-----
Thread Connection	Polypropylene (PPG)	Rc/Rc NPT/NPT	NDP-25BPC (851669) (851671)	NDP-25BPN (852598) (852385)	NDP-25BPE (852600) (852386)	NDP-25BPV (852599) (852387)	NDP-25BPT (852570) (851672)	NDP-25BPH (851735) (852070)	NDP-25BPH/T (851881) (-----)	NDP-25BPS (852699) (852704)
	Kynar <sup>®</sup> (PVDF)	Rc/Rc NPT/NPT	-----	-----	NDP-25BVE* (853594) (852811)	NDP-25BVV* (852900) (852810)	NDP-25BVT* (852218) (852219)	NDP-25BVH* (852278) (852279)	-----	-----



\* Purchaser shall not directly or indirectly, export, re-export transship or otherwise transfer this product in violation of any applicable export control laws and regulations promulgated and administered by the governments of the countries asserting jurisdiction over the parties or transaction.

### Dimensions

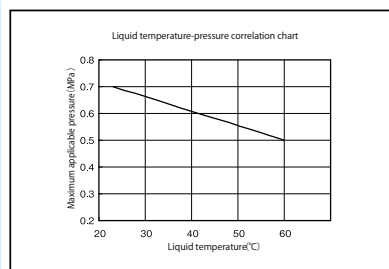
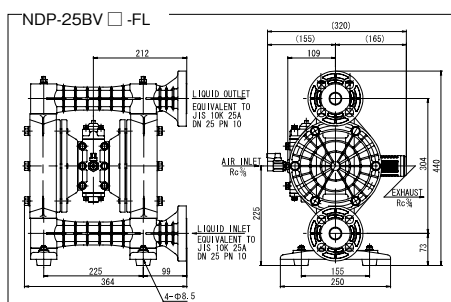
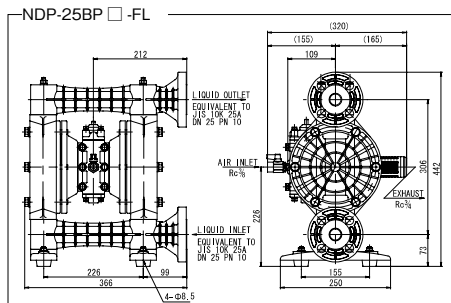

### Performance Curve

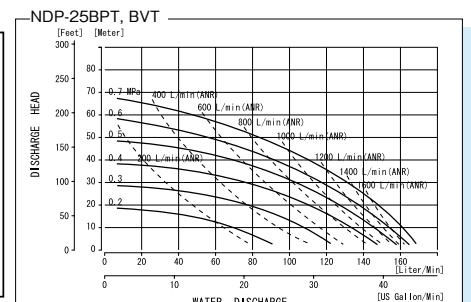
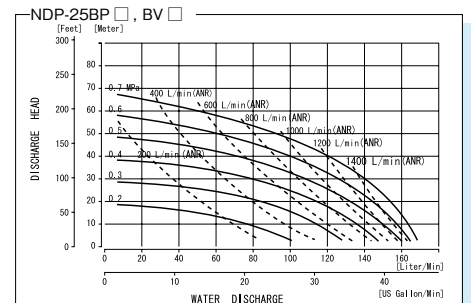



# NDP-32 Series

190L/min Maximum Flow Rate  
1-1/2" Intake, 1-1/4" Discharge

## Specifications

Port Size		IN 1-1/2" (40A), OUT 1-1/4" (32A)
Liquid	Intake	Rc1-1/2" or NPT1-1/2"
	Discharge	Rc1-1/4" or NPT1-1/4"
Air	Supply	Rc3/8" or NPT3/8" includes ball valve
	Exhaust	Rc3/4" or NPT3/4" w/ silencer
Air Supply Pressure		0.2-0.7MPa
Maximum Discharge Pressure		0.7MPa
Discharge Volume Per Cycle		Rubber diaphragm : 670mL PTFE diaphragm : 560mL
Maximum Size Solid		3mm
Net Weight		12.0kg

## Body Materials

Models	NDP-32BAN	NDP-32BAT
Check Valve	Same material as the diaphragm	
Valve Seat	SMS1025	SUS316
Valve Guide	A5056	SCS14
Center Disk	A5056	SUS316

✓ Maximum Dry Suction Lift is 5M for Rubber Diaphragm and 2M for PTFE Diaphragm

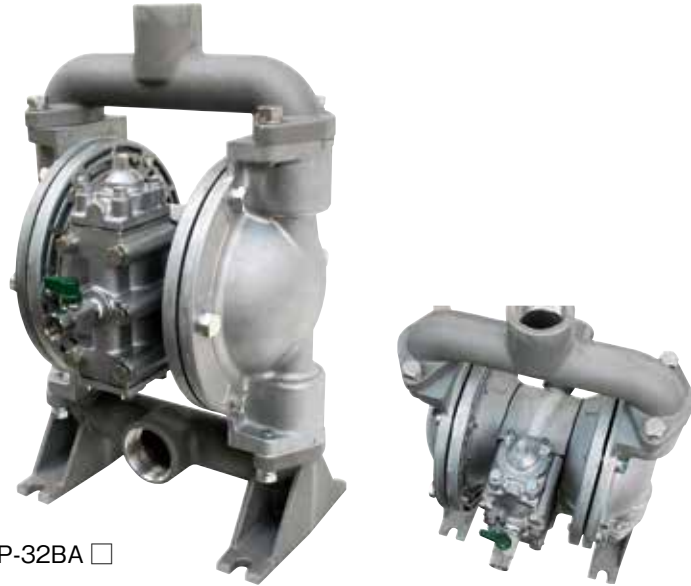

NDP-32BA □

## Model Chart

Body Material	Connection Liquid/Air	Diaphragm Material	
		Buna N (NBR)	PTFE
Aluminum (ADC12)	Rc/Rc	NDP-32BAN (854612)	NDP-32BAT (854613)
	NPT/NPT	(854575)	(854576)

## Dimensions

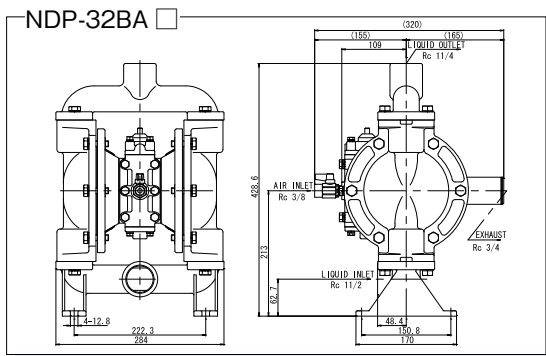

## Performance Curve

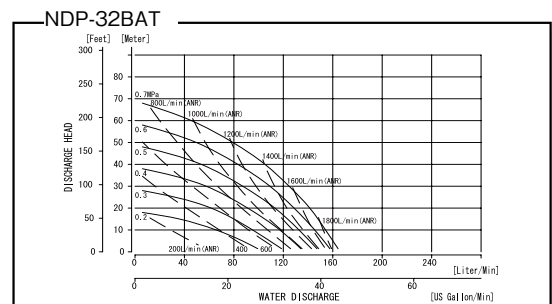
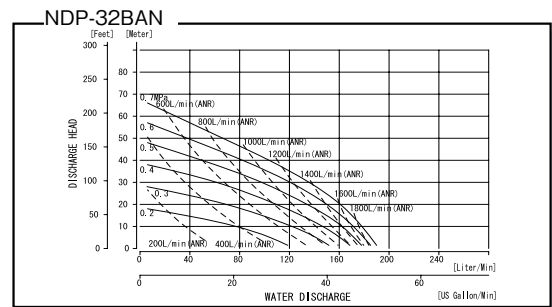

# NDP-40 Series

400L/min Maximum Flow Rate  
1-1/2 inch Port Size

## Specifications

Port Size		1-1/2" (40A)
Liquid	Intake	BA □ models: JIS/DIN/ANSI Compatible Flange or ANSI Flange w/ NPT BS □ models: JIS/DIN/ANSI Compatible Flange or ANSI Flange
	Discharge	BF □ models: Rc1-1/2" or NPTF1-1/2"
Air	Supply	Rc1/2" or NPT1/2" includes ball valve
	Exhaust	Rc1" or NPT1" w/ silencer
Air Supply Pressure		0.2-0.7MPa
Maximum Discharge Pressure		0.7MPa

Discharge Volume Per Cycle	Rubber diaphragm: 2.8L PTFE diaphragm: 1.4L
Maximum Size Solid	7mm
Net Weight	NDP-40BA □: 29.0kg
	NDP-40BS □: 40.0kg
	NDP-40BF □: 47.0kg
	NDP-40BV □: 27.0kg
NDP-40BP □: 27.0kg	

## Metal Body Pumps



NDP-40BA □



NDP-40BS □



NDP-40BF □

## Model Chart

Body Material	Connection Liquid/Air	Diaphragm Material							
		Neoprene (CR)	Buna N (NBR)	EPDM	Viton® (FKM)	PTFE	Hytrel® (TPEE)	Hytrel® (TPEE)	Santoprene® (TPO)
Aluminum (ADC12)	JIS-DIN/Rc ANSI-NPT/NPT	NDP-40BAC (852655) (852417)	NDP-40BAN (852320) (852220)	NDP-40BAE (852656) (852418)	NDP-40BAV (852310) (852300)	NDP-40BAT (852322) (852222)	NDP-40BAH (852321) (852221)	NDP-40BAH/T (853025) (-----)	NDP-40BAS (852706) (852709)
		NDP-40BSC (852657) (852419)	NDP-40BSN (852323) (852223)	NDP-40BSE (852658) (852420)	NDP-40BSV (852311) (852301)	NDP-40BST (852325) (852225)	NDP-40BSH (852324) (852224)	NDP-40BSH/T (853026) (-----)	NDP-40BSS (852707) (852710)
Stainless Steel (SCS14/SUS316)	JIS-DIN/Rc ANSI-NPT	NDP-40BSC (852657) (852419)	NDP-40BSN (852323) (852223)	NDP-40BSE (852658) (852420)	NDP-40BSV (852311) (852301)	NDP-40BST (852325) (852225)	NDP-40BSH (852324) (852224)	NDP-40BSH/T (853026) (-----)	NDP-40BSS (852707) (852710)
Cast Iron (S45C)	Rc/Rc NPT/NPT	NDP-40BFC (852866) (852873)	NDP-40BFN (852862) (852869)	NDP-40BFE (852867) (852874)	NDP-40BFV (852865) (852872)	NDP-40BFT (852864) (852871)	NDP-40BFH (852863) (852870)	NDP-40BFH/T (853027) (-----)	NDP-40BFS (852868) (852875)

## Dimensions

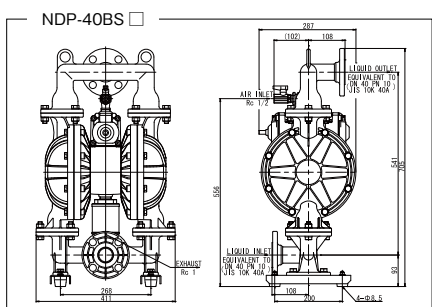
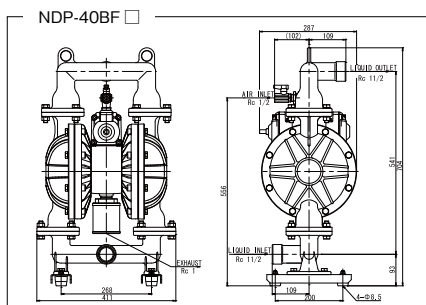
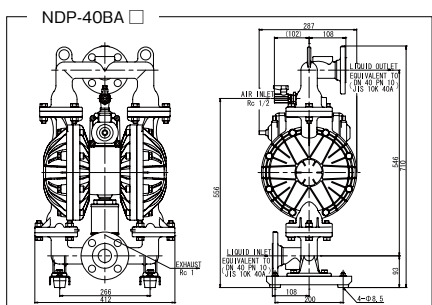

## Performance Curve

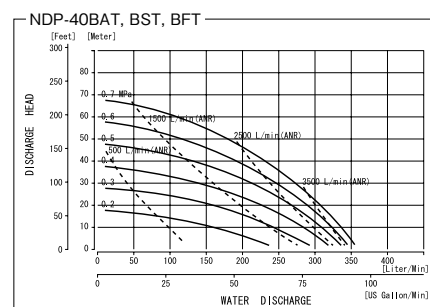
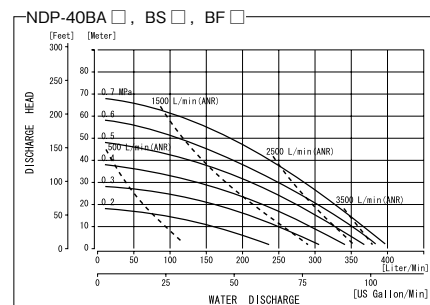

# Body Materials

Models	NDP-40BA□	NDP-40BS□	NDP-40BF□	NDP-40BP□	NDP-40BV□
Check Valve	Same material as the diaphragm (PTFE for B□H/T models)				
Valve Seat	Same material as the diaphragm			PPG	PVDF
	BAT: A5056	BST: SUS316	BFT: SUS316		
Valve Guide	Same material as the Pump Body (integral type)				
Center Disk	A5056	SUS316	SS400	PPG (SCS13*)	PVDF (SCS13*)

\* Material of the insert

✓ Maximum Dry Suction Lift is 5M for Rubber Diaphragm and 3M for PTFE Diaphragm

## Plastic Body Pumps



Air supply pressure of Plastic Body Pumps is depending on the liquid temperature. Be sure to check the Liquid temperature – Pressure Correlation Chart.



NDP-40BP □



NDP-40BV □

### Model Chart

Body Material	Connection Liquid/Air	Diaphragm Material							
		Neoprene (CR)	Buna N (NBR)	EPDM	Viton® (FKM)	PTFE	Hytrel®(TPEE)	Hytrel®(TPEE)	Santoprene®(TPO)
Polypropylene (PPG)	JIS·DIN/Rc ANSI/NPT	NDP-40BPC (852659) (852421)	NDP-40BPN (852326) (852226)	NDP-40BPE (852660) (852422)	NDP-40BPV (852312) (852302)	NDP-40BPT (852328) (852228)	NDP-40BPH (852827) (852227)	NDP-40BPH/T (853028) (-----)	NDP-40BPS (852708) (852711)
Kynar® (PVDF)	JIS·DIN/Rc ANSI/NPT	-----	-----	NDP-40BVE* (853863) (-----)	-----	NDP-40BVT* (853864) (853797)	-----	-----	NDP-40BVS* (853865) (853798)



\* Purchaser shall not directly or indirectly, export, re-export transship or otherwise transfer this product in violation of any applicable export control laws and regulations promulgated and administered by the governments of the countries asserting jurisdiction over the parties or transaction.

### Dimensions

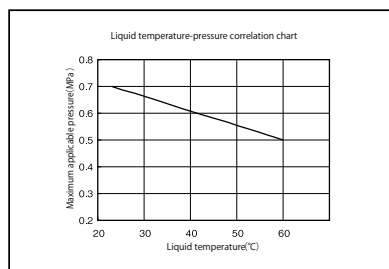
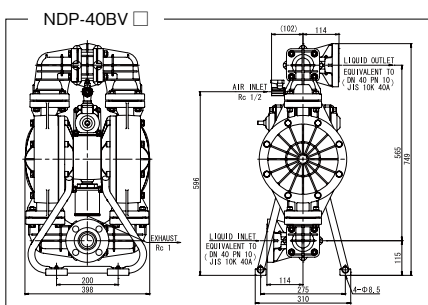
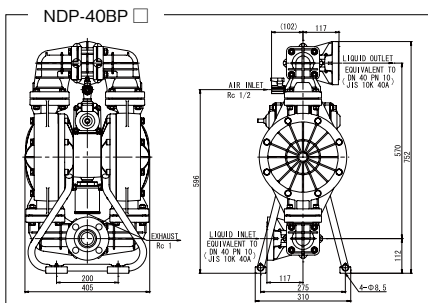

### Performance Curve

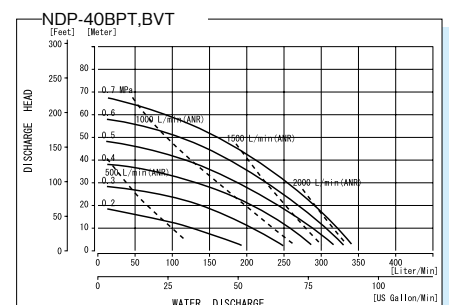
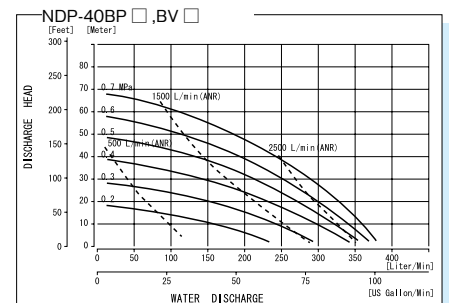

# NDP-50 Series

600L/min Maximum Flow Rate  
2 inch Port Size

## Specifications

Port Size		2" (50A)
Liquid	Intake	BA □ models: JIS/DIN/ANSI Compatible Flange or ANSI Flange w/ NPTF BS □ models: JIS/DIN/ANSI Compatible Flange or ANSI Flange BF □ models: Rc2" or NPTF2"
	Discharge	BF □ models: Rc2" or NPTF2"
Air	Supply	Rc3/4" or NPT3/4" includes ball valve
	Exhaust	Rc1" or NPT1" w/ silencer
Air Supply Pressure		0.2-0.7MPa
Maximum Discharge Pressure		0.7MPa

Discharge Volume Per Cycle	Rubber diaphragm: 4.3L PTFE diaphragm: 2.1L
Maximum Size Solid	8mm
Net Weight	NDP-50BA □: 37.0kg
	NDP-50BS □: 60.0kg
	NDP-50BF □: 65.0kg
	NDP-50BP □: 35.0kg
	NDP-50BV □: 41.0kg

## Metal Body Pumps



NDP-50BA □



NDP-50BS □



NDP-50BF □

## Model Chart

Body Material	Connection Liquid/Air	Diaphragm Material							
		Neoprene (CR)	Buna N (NBR)	EPDM	Viton® (FKM)	PTFE	Hytrel® (TPEE)	Hytrel® (TPEE)	Santoprene® (TPO)
Aluminum (ADC12)	JIS-DIN/Rc ANSI-NPT/NPT	NDP-50BAC (852661) (852423)	NDP-50BAN (852329) (852229)	NDP-50BAE (852662) (852424)	NDP-50BAV (852313) (852303)	NDP-50BAT (852331) (852231)	NDP-50BAH (852330) (852230)	NDP-50BAH/T (853029) (-----)	NDP-50BAS (852713) (852717)
		NDP-50BSC (852663) (852425)	NDP-50BSN (852332) (852232)	NDP-50BSE (852664) (852426)	NDP-50BSV (852314) (852304)	NDP-50BST (852334) (852234)	NDP-50BSH (852333) (852233)	NDP-50BSH/T (853030) (-----)	NDP-50BSS (852714) (852721)
Stainless Steel (SCS14/SUS316)	JIS-DIN/Rc ANSI-NPT	NDP-50BSC (852663) (852425)	NDP-50BSN (852332) (852232)	NDP-50BSE (852664) (852426)	NDP-50BSV (852314) (852304)	NDP-50BST (852334) (852234)	NDP-50BSH (852333) (852233)	NDP-50BSH/T (853030) (-----)	NDP-50BSS (852714) (852721)
		NDP-50BSC (852663) (852425)	NDP-50BSN (852332) (852232)	NDP-50BSE (852664) (852426)	NDP-50BSV (852314) (852304)	NDP-50BST (852334) (852234)	NDP-50BSH (852333) (852233)	NDP-50BSH/T (853030) (-----)	NDP-50BSS (852714) (852721)
Cast Iron (S45C)	Rc/Rc NPT/NPT	NDP-50BFC (852834) (852841)	NDP-50BFN (852830) (852837)	NDP-50BFE (852835) (852842)	NDP-50BFV (852833) (852840)	NDP-50BFT (852832) (852839)	NDP-50BFH (852831) (852838)	NDP-50BFH/T (853031) (-----)	NDP-50BFS (852836) (852843)
		NDP-50BFC (852834) (852841)	NDP-50BFN (852830) (852837)	NDP-50BFE (852835) (852842)	NDP-50BFV (852833) (852840)	NDP-50BFT (852832) (852839)	NDP-50BFH (852831) (852838)	NDP-50BFH/T (853031) (-----)	NDP-50BFS (852836) (852843)

## Dimensions

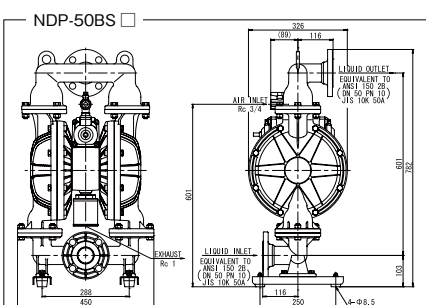
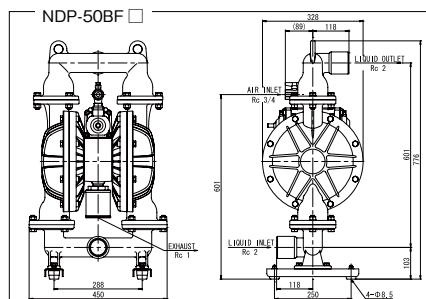
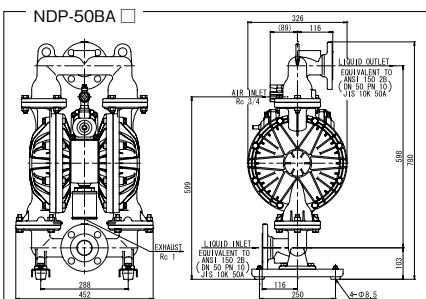

## Performance Curve

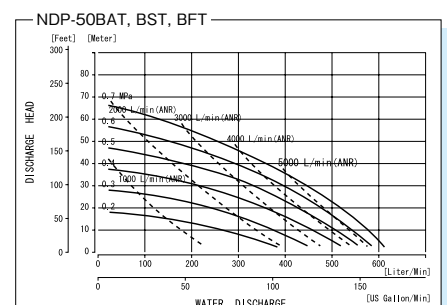
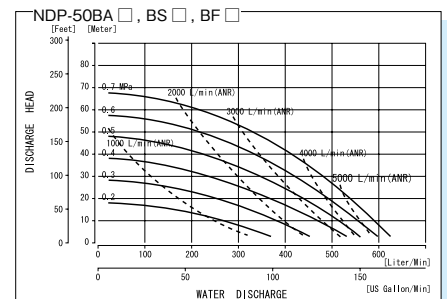

# Body Materials

Models	NDP-50BA□	NDP-50BS□	NDP-50BF□	NDP-50BP□	NDP-50BV□
Check Valve	Same material as the diaphragm (PTFE for B□/H/T models)				
Valve Seat	Same material as the diaphragm			PPG	PVDF
	BAT: A5056	BST: SUS316	BFT: SUS316		
Valve Guide	Same material as the Pump Body (integral type)				
Center Disk	A5056	SUS316	SS400	PPG (SCS13*)	PVDF (SCS13*)

\* Material of the insert

✓ Maximum Dry Suction Lift is 5M for Rubber Diaphragm and 3M for PTFE Diaphragm

## Plastic Body Pumps



Air supply pressure of Plastic Body Pumps is depending on the liquid temperature. Be sure to check the Liquid temperature – Pressure Correlation Chart.



NDP-50BP □



NDP-50BV □

### Model Chart

Body Material	Connection Liquid/Air	Diaphragm Material							
		Neoprene (CR)	Buna N (NBR)	EPDM	Viton® (FKM)	PTFE	Hytrel® (TPEE)	Hytrel® (TPEE)	Santoprene® (TPO)
Polypropylene (PPG)	JIS·DIN/Rc	NDP-50BPC (852665)	NDP50BPN (852335)	NDP-50BPE (852666)	NDP-50BPV (852315)	NDP-50BPT (852337)	NDP-50BPH (852336)	NDP-50BPH/T (853032)	NDP-50BPS (852715)
	ANSI/NPT	(852427)	(852235)	(852428)	(852305)	(852237)	(852236)	(.....)	(852719)
Kynar® (PVDF)	JIS·DIN/Rc	-----	-----	NDP-50BVE* (853272)	NDP-50BVV* (853273)	NDP-50BVT* (852484)	NDP-50BVH* (852488)	-----	NDP-50BVS* (852776)
	ANSI/NPT	-----	-----	(852813)	(852812)	(852485)	(852489)	-----	(852775)



\* Purchaser shall not directly or indirectly, export, re-export transship or otherwise transfer this product in violation of any applicable export control laws and regulations promulgated and administered by the governments of the countries asserting jurisdiction over the parties or transaction.

### Dimensions

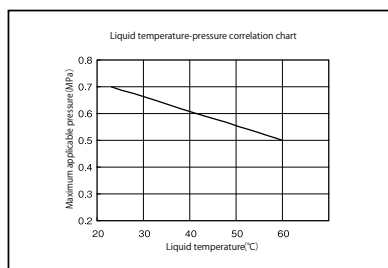
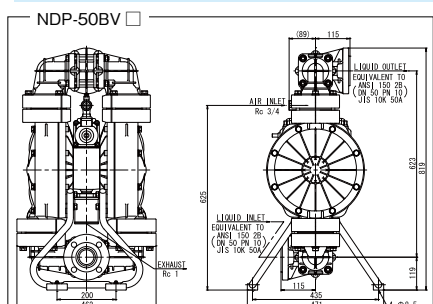
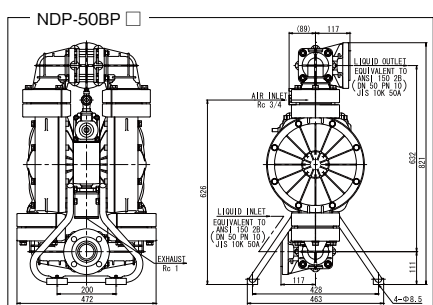

### Performance Curve

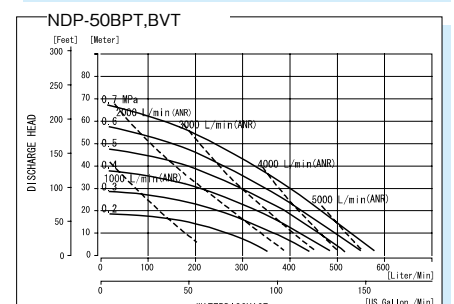
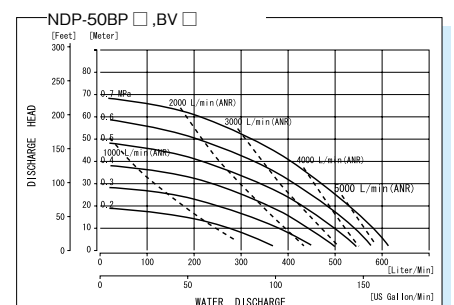

# NDP-80 Series

800L/min Maximum Flow Rate  
3 inch Port Size

## Specifications

Port Size		3" (80A)
Liquid	Intake	BA□ models: JIS/DIN Compatible Flange or ANSI Flange w/ NPTF BS□ models: JIS/DIN Compatible Flange or ANSI Flange (Rc3" or NPT3" for BF□ models)
	Discharge	JIS/DIN/ANSI Compatible Flange (Rc3" or NPT3" for BF□ models)
Air	Supply	Rc3/4" or NPT3/4" includes ball valve
	Exhaust	Rc1" or NPT1" w/ silencer
Air Supply Pressure		0.2 - 0.7MPa
Maximum Discharge Pressure		0.7MPa

Discharge Volume Per Cycle	Rubber diaphragm: 8.5L PTFE diaphragm: 3.8L
Maximum Size Solid	10mm
Net Weight	NDP-80BA□: 65.0kg
	NDP-80BS□: 102.0kg
	NDP-80BF□: 112.0kg
	NDP-80BP□: 64.0kg

## Metal Body Pumps



NDP-80BA □



NDP-80BS □



NDP-80BF □

## Model Chart

Body Material	Connection Liquid/Air	Diaphragm Material							
		Neoprene (CR)	Buna N (NBR)	EPDM	Viton® (FKM)	PTFE	Hytrel® (TPEE)	Hytrel® (TPEE)	Santoprene® (TPO)
Aluminum (ADC12)	JIS-DIN/Rc ANSI-NPT/NPT	NDP-80BAC (852667) (852429)	NDP-80BAN (852338) (852238)	NDP-80BAE (852668) (852430)	NDP-80BAV (852316) (852306)	NDP-80BAT (852340) (852240)	NDP-80BAH (852339) (852239)	NDP-80BAH/T (853033) (-----)	NDP-80BAS (852722) (852725)
Stainless Steel (SCS14/SUS316)	JIS-DIN/Rc ANSI-NPT	NDP-80BSC (852669) (852431)	NDP-80BSN (852341) (852241)	NDP-80BSE (852670) (852432)	NDP-80BSV (852317) (852307)	NDP-80BST (852343) (852243)	NDP-80BSH (852342) (852242)	NDP-80BSH/T (853034) (-----)	NDP-80BSS (852723) (852726)
Cast Iron (S45C)	Rc/Rc NPT/NPT	NDP-80BFC (852852) (852859)	NDP-80BFN (852848) (852855)	NDP-80BFE (852853) (852860)	NDP-80BFV (852851) (852858)	NDP-80BFT (852850) (852857)	NDP-80BFH (852849) (852856)	NDP-80BFH/T (853035) (-----)	NDP-80BFS (852724) (852861)

## Dimensions

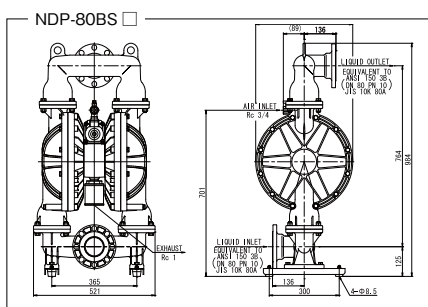
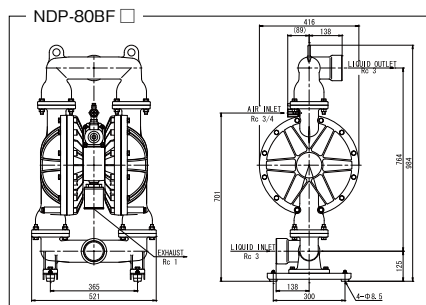
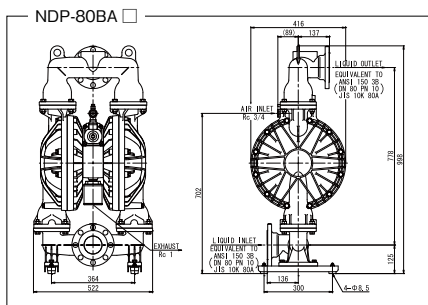

## Performance Curve

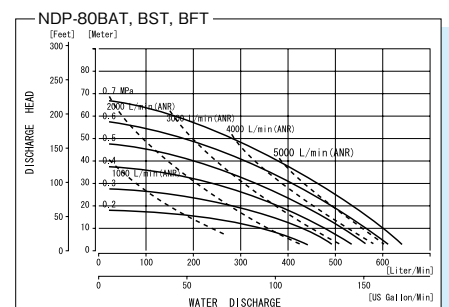
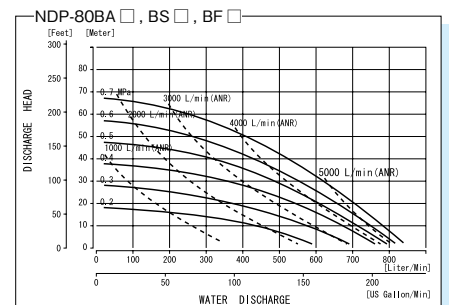

# Body Materials

Models	NDP-80BA□	NDP-80BS□	NDP-80BF□	NDP-80BP□
Check Valve	Same material as the diaphragm (PTFE for B□H/T models)			
Valve Seat	Same material as the diaphragm			PPG
	BAT: A5056	BST: SUS316	BFT: SUS316	
Valve Guide	Same material as the Pump Body (integral type)			
Center Disk	A5056	SUS316	SS400	PPG (SCS13*)

\* Material of the insert

✓ Maximum Dry Suction Lift is 5M for Rubber Diaphragm and 3M for PTFE Diaphragm

## Plastic Body Pumps



Air supply pressure of Plastic Body Pumps is depending on the liquid temperature. Be sure to check the Liquid temperature – Pressure Correlation Chart.



NDP-80BP □

### Model Chart

Body Material	Connection Liquid/Air	Diaphragm Material							
		Neoprene (CR)	Buna N (NBR)	EPDM	Viton® (FKM)	PTFE	Hytrel®(TPEE)	Hytrel®(TPEE)	Santoprene®(TPO)
Polypropylene (PPG)	JIS·DIN/Rc ANSI/NPT	NDP-80BPC (852671) (852433)	NDP-80BPN (852344) (852244)	NDP-80BPE (852672) (852434)	NDP-80BPV (852318) (852308)	NDP-80BPT (852346) (852246)	NDP-80BPH (852345) (852245)	NDP-80BPH/T (853036) (-----)	NDP-80BPS (852724) (852727)

### Dimensions

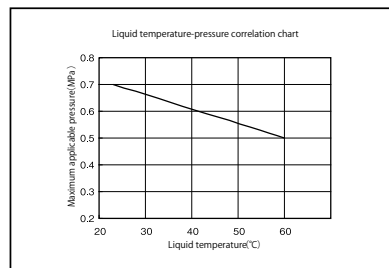
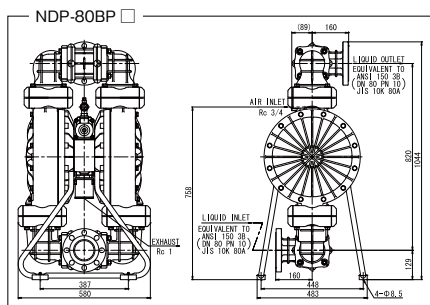

### Performance Curve

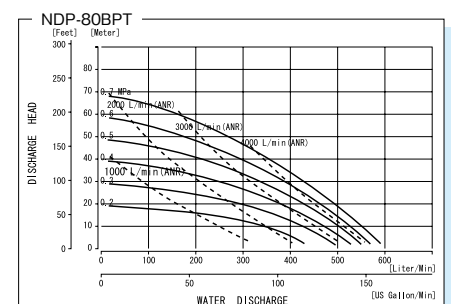
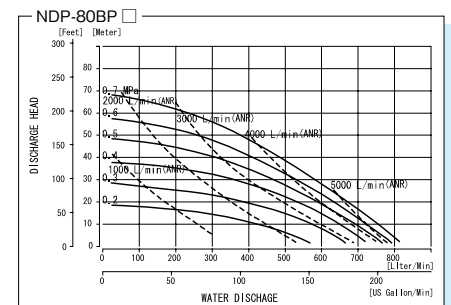

# Flap Valve Series

**30mm of Maximum Size of Solid  
2 inch Port Size**

The Yamada Flap Valve Pump is designed to pump fluids containing solids up to 30mm in diameter. Built on the foundation of the NDP Series line of pumps, the Flap Valve Pump incorporates the Yamada patented stall-free/lube-free air valve and rugged, easy-to-service bolted construction.

Designed for durability in the field, the Flap Valve Pump's innovative flap-type check valve technology provides streaming passage of solids while minimizing clogging and downtime. Four external bolts release valve covers on either side permitting service and maintenance without removing the pump from service.



✓ For additional information, please request the Flap Valve Series catalog or visit [www.yamadacorp.co.jp/global](http://www.yamadacorp.co.jp/global)

# Mechanical Switch Series

**0.1 – 0.85MPa of Discharge Pressure  
1-1/2 inch, 2 inch and 3 inch Port Size**

The Yamada Mechanical Switch Pump is designed for use in process type applications including filter press, high pressure, extended deadheading, long runs of discharge pipe, and where air consumption is critical.

Available in 1-1/2", 2" and 3" port sizes, these pumps are built on the liquid platform of a standard NDP Series pump, but with a mechanically-actuated air motor.

Air power is conserved by actuating the air valve using a mechanical linkage instead of relying on air pressure. Air power is reduced versus a standard air-actuated valve, providing higher pump efficiency.



✓ For additional information, please request the Mechanical Switch Series catalog or visit [www.yamadacorp.co.jp/global](http://www.yamadacorp.co.jp/global)

# F-Series High Purity Pumps

**Clean Room Manufactured  
1/4 inch to 1 inch Port Size**

Extensively field proven, Yamada F-Series clean room manufactured pumps are specifically designed for the safe and efficient transfer of ultra high-purity process chemistries. They provide maximum corrosion resistance, ultra high-purity levels and low particle generation.

Pumps includes 100% machined virgin PTFE diaphragms, liquid chambers and manifolds.



✓ For additional information, please request the High Purity Pumps catalog or visit [www.yamadacorp.co.jp/global](http://www.yamadacorp.co.jp/global)

# E-Series Solenoid Operated Pumps

**External Electric Solenoid Controlled  
3/4 inch to 3 inch Port Size**

This range of pumps is designed to operate using an external electronic pump driver coupled to a proximity sensor built into the pump. They provide the operator with unrivaled operational performance, reliability and cost effectiveness. This system removes any change of pump stoppages caused from blockages or failures of a standard internal air switching system.



✓ For additional information, please request the Solenoid Operated Pumps catalog or visit [www.yamadacorp.co.jp/global](http://www.yamadacorp.co.jp/global)



# Drum Pumps

Fit to 200L Drum  
3/8 inch and 3/4 inch Port Size



## Specifications

Port Size		3/8" (10A)	3/4" (20A)
Liquid	Intake	Ø17.3 O.D.	Ø34.0 O.D.
	Discharge	Rc3/8"	Rc3/4"
Air	Supply	Rc1/4" incl. ball valve	Rc1/4" incl. ball valve
	Exhaust	Rc1/8" incl. silencer	Rc3/4" incl. silencer
Air Supply Pressure		0.2-0.7MPa	0.2-0.7MPa
Maximum Discharge Pressure		0.7MPa	0.7MPa
Discharge Volume Per Cycle		50mL	BA□:350mL BAT:240mL
Maximum Size Solid		1mm	2mm
Net Weight		BA□:4.5kg BS□:6.2kg	10.7kg
Accessories		713237 Suction Pipe (SUS304) 803665 Bung Adapter (ADC12)	709406 Suction Pipe (SGP) 803667 Bung Adapter (SS400)

✓ Please refer to DP-10 and NDP-20 Series technical information for additional performance data.

## Dimensions

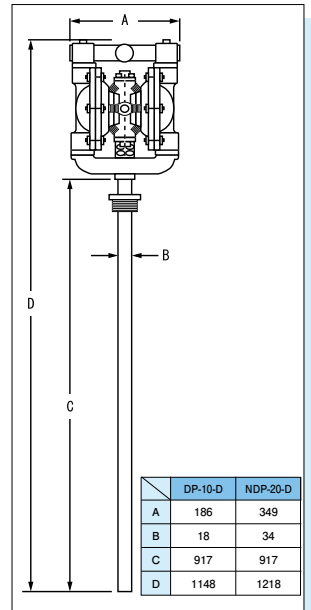

## Model Chart

	Body Material	Diaphragm Material			
		Neoprene (CR)	Buna N (NBR)	PTFE	Hytrel® (TPEE)
DP-10	Aluminum (ADC12)	DP-10BAC-D (852918)	DP-10BAN-D (852919)	DP-10BAT-D (852920)	DP-10BAH-D (852934)
	Stainless Steel (SCS14/SUS316)	DP-10BSC-D (852921)	DP-10BSN-D (852922)	DP-10BST-D (852923)	DP-10BSH-D (852935)
NDP-20	Aluminum (ADC12)	NDP-20BAC-D (851397)	NDP-20BAN-D (851396)	NDP-20BAT-D (851398)	NDP-20BAH-D (852827)

# Powder Pumps

For dry powder transfer  
1 inch to 3 inch Port Size

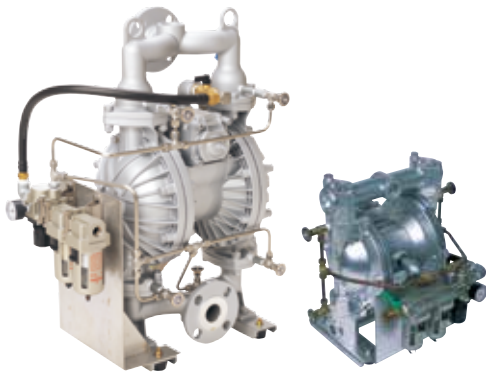

✓ For additional information, please request the Powder Pumps catalog or visit [www.yamadacorp.co.jp/global](http://www.yamadacorp.co.jp/global)

Yamada Powder Pumps are designed to move bulk powders more effectively throughout your process vs. other unsafe and labor intensive means. These heavy duty pumps will consistently transfer fine-grained, low-bulk density dry powders in a dust-free operation.

# High Pressure Pumps

2:1 Ratio  
3/4 inch to 3 inch Port Size

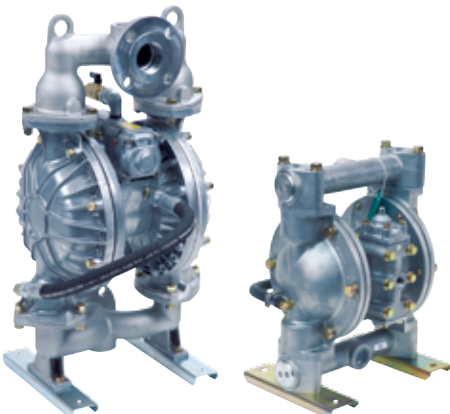

✓ For additional information, please request the High Pressure Pumps catalog or visit [www.yamadacorp.co.jp/global](http://www.yamadacorp.co.jp/global)

Yamada High Pressure Pumps are designed for applications when a maximum 0.7MPa operating pressure is insufficient to overcome system requirements.

The flow rate is roughly half of the equivalent size pump output, through a maximum discharge pressure of 1.4MPa can be achieved with only 0.7MPa air inlet pressure supplied.

The 2:1 discharge ratio is achieved by applying air pressure to the surface area of both diaphragms, doubling the discharge output.

# Specialty Pumps

## FDA Compliant Pumps

Yamada FDA Compliant Pumps are specifically designed for Food, Pharmaceutical & Cosmetic industries where 3A or USDA standards are not required.

Pumps include 316 Stainless Steel wetted components with passivated satin finish, PTFE-coated air motor, sanitary clamp fittings, and FDA compliant elastomers.



✓ For additional information, please request the FDA Compliant Pumps catalog or visit [www.yamadacorp.co.jp/global](http://www.yamadacorp.co.jp/global)

## CSA Certified Pumps

Yamada offers a series of three CSA certified pumps, each built on the consistently designed foundation of the field proven DP- and NDP-Series pumps. Pumps are constructed with aluminum wetted components and durable Buna N elastomers certified by CSA International.

Available in 3/4", & 1" port sizes with flow rates from 1–46 GPM. Note: CSA Certification Class 3305-10 & 3305-90 limits natural gas temperature range to 32°F–125°F.



✓ For additional information, please request the CSA Certified Pumps catalog or visit [www.yamadacorp.co.jp/global](http://www.yamadacorp.co.jp/global)

## U.L. Listed Pumps

Yamada U.L. listed pumps are manufactured for the petrochemical, chemical, and petroleum industries to meet safety requirements established by Underwriters Laboratory Code 79. Pumps include Aluminum wetted components with durable Hytrel® and PTFE elastomers, approved by U.L. to transfer volatile fluids.

Pumps are available in 3/4" and 1" port sizes, with flow ranges from 1–46 gallons per minute.

U.L. Code 79 limits pump discharge pressures to no more than 50 PSI and pumping temperatures must adhere to the range of –20°F to 125° F.



✓ For additional information, please request the U.L. Listed Pumps catalog or visit [www.yamadacorp.co.jp/global](http://www.yamadacorp.co.jp/global)

## ATEX Compliant Pumps

Select Yamada DP and Yamada NDP Series pumps are compliant with ATEX guidelines for safe pump operation in potentially dangerous or explosive areas. Please consult Yamada.

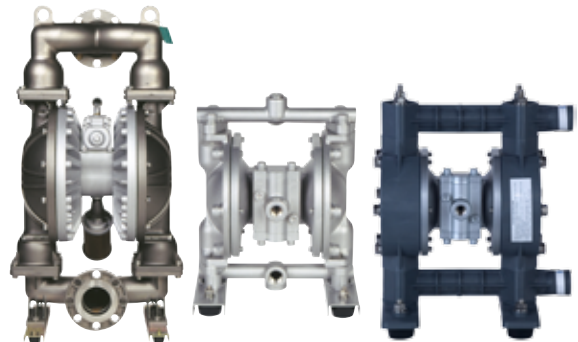

# Accessories

## Filter/Regulators

Model No.	Model	Fits Pump
684328	AC20B-02G-A	NDP-5, DP-10, NDP-15
150000	AC25B-02G-A	NDP-20/P20
684330	AC30B-03G-A	NDP-25/P25, 32
150000	AC40B-04G-A	NDP-40/H40
150000	AC40B-06G-A	NDP-50/H50, 80/H80



## Companion Flange / Raised Pump Bracket

JIS, DIN, ANSI and Ferrule  
Flanges made of SUS304 or PP



Raised Pump Bracket  
is available on request

## Diaphragm Monitoring Kits

This unit detects liquid leak caused by diaphragm rupture immediately and prevents secondary troubles.

- ✓ Liquid with no conductivity (50kΩ or less) cannot be detected
- ✓ Not the explosion-proof
- ✓ Modification on the air chambers is required for installation



Model No.	Model	Fits Pump	Power Supply
804566	DMS-24T	Except NDP-5 to 15	DC24V

### Optional Accessories

Model No.	Model, Description
685968	DMS-NT24 AC Adapter
685969	Extension sensor cord 5M

## Pneumatic Cycle Counter

Pneumatic 8-digit  
mechanical type counter



- ✓ No count up in dry run
- ✓ No reset function
- ✓ Modification on the center body is required for installation

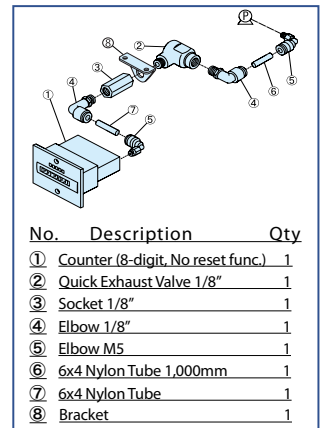

No.	Description	Qty
①	Counter (8-digit, No reset func.)	1
②	Quick Exhaust Valve 1/8"	1
③	Socket 1/8"	1
④	Elbow 1/8"	1
⑤	Elbow M5	1
⑥	6x4 Nylon Tube 1,000mm	1
⑦	6x4 Nylon Tube	1
⑧	Bracket	1

Model No.	Model	Fits Pump
803413	NMC-ANS	NDP Series*
804542	NMC-ANF	NDP-5, 15
804847	NMC-ANH	NDP-H Series

\*Except NDP-P20, P25

## Dry-Run Detector

The Yamada ESV-06/DRD-100 detects increases in air volume due to loss of prime or dry-running, and automatically shuts down the pump to prevent excess cycling and increased diaphragm wear.



Model No.	Model	Supply Air Press	Usable Gas	Air Inlet	Air Outlet
854006	ESV-06	0.2-0.99MPa	Air / Nitrogen	Rc3/4"	Rc3/4"
854008	DRD-100			NPT3/4"	NPT3/4"

## Anti-Stall Device

Retrofit-able kit that pneumatically activates the air valve instantly starting pump operation

**\*Please use with dedicated sleeve**

### Dedicated Sleeve

Model No.	Model
804739	Sleeve for SVT225
804740	Sleeve for SVT458



Model No.	Model	Fits Pump
804066	SVT-225	NDP-20, 25, 32
804065	SVT-458	NDP-40, 50, 80

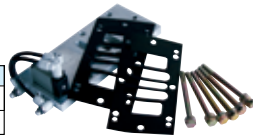

## High-Low Level Controller

This unit is used to control the high and low levels of liquid being pumped into or out of a container. This device is driven by compressed air and is therefore suitable for use in highly explosive environments.

The system is also designed to work in many harsh environments, e.g. areas with high temperature, high humidity or even areas where there are high electromagnetic fields. It can handle any liquid with a viscosity of less than 1000cps.



Model No.	Model	Supply Air Press.	Output Air Flow	Viscosity Limit	Weight
480005	SA-4150	0.3-0.7MPa	Max 300L/min	1Pa·s or less	6kg

## Suction Tube Kit for Drum

This Suction Tube kit fits to the 200L drum. Pump is recommended to be mounted at the height of 1M from floor level.

Material	Model No.	Model	Fits Pump	Hose	Connection	Accessories	Remark
Carbon steel	850126	SCK-200D	Size 20	Oil hose 3/4"x2M	R3/4" with Rc1-1/2" socket	Drum bung adapter (ADC12)	Please prepare suitable connector separately.
	851004	SCK-200D-HV	Size 25,40	Oil hose 1"x2M	R1" with Rc1-1/2" socket	Drum bung adapter (ADC12)	
SUS 304	803407	STU-20-20	Size 20	Not included	Rc3/4"	Drum bung adapter (SUS304)	Please prepare suitable hose and connector separately.
	803405	STU-25-25	Size 25		Rc1"		
	803406	STU-40-40	Size 40		Rc1-1/2"		

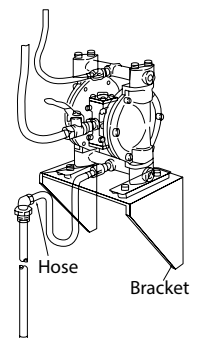

# Pulsation Dampeners 3/8", 1", 1-1/2" and 2" Port Size

Yamada AD Pulsation Dampeners incorporate a flow-through design which keeps solids in suspension, maintaining damper effectiveness.



## Installation Diagram

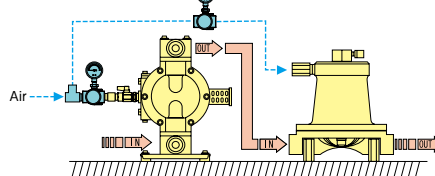

1. Damper should be installed within 1M of the pump
2. Adjustment of supply air pressure increases the effectiveness
3. Damper will consume air depending on condition of the pulse
4. Pre-adjustments are required prior to operation
5. Damper will work best with at least 0.1MPa of backpressure

## AD-10 Series (fit to NDP-5, NDP-15 and DP-10)

### Specifications

Port Size		3/8" (10A)
Liquid	Intake	Rc3/8" or NPT3/8"
	Discharge	Rc3/8" or NPT3/8"
Air	Supply	Rc1/4" or NPT1/4"
	Exhaust	Rc1/8" w/ silencer
Air Supply Pressure		0.2 - 0.7MPa
Maximum Discharge Pressure		0.7MPa
Net Weight		AD-10A □ : 2.1kg
		AD-10S □ : 3.0kg
		AD-10P □ : 2.1kg

**!** Air supply pressure of Plastic Body Pumps is depending on the liquid temperature. Be sure to check the Liquid temperature – Pressure Correlation Chart.

### Model Chart

Body Material	Connection Liquid/Air	Diaphragm Material				
		Neoprene (CR)	Buna N (NBR)	PTFE	Hytre® (TPEE)	Santoprene® (TPO)
Aluminum (ADC12)	Rc/Rc	AD-10AC (851795)	AD-10AN (851791)	AD-10AT (851796)	AD-10AH (851792)	AD-10AS (853317)
	NPT/NPT	(853318)	(853315)	(853315)	(853332)	(853333)
Stainless Steel (SCS14/SUS316)	Rc/Rc	AD-10SC (851795)	AD-10SN (851794)	AD-10ST (851757)	AD-10SH (851763)	AD-10SS (853322)
	NPT/NPT	(853318)	(853319)	(853320)	(853321)	(854047)
Polypropylene (PPG)	Rc/Rc	AD-10PC (854045)	AD-10PN (853324)	AD-10PT (854046)	AD-10PH (853326)	AD-10PS (853327)
	NPT/NPT	(853323)	(853324)	(853325)	(853326)	(853327)

## AD-25 Series (fit to NDP-20/P20, NDP-25/P25 and NDP-32)

### Specifications

Port Size		1" (25A)
Liquid	Intake	Rc1" or NPT1"
	Discharge	Rc1" or NPT1"
Air	Supply	Rc1/4" or NPT1/4"
	Exhaust	Rc1/8" w/ silencer
Air Supply Pressure		0.2 - 0.7MPa
Maximum Discharge Pressure		0.7MPa
Net Weight		AD-25A □ : 5.8kg
		AD-25S □ : 8.2kg
		AD-25F □ : 8.2kg
		AD-25P □ : 5.5kg
		AD-25V □ : 6.3kg

**!** Air supply pressure of Plastic Body Pumps is depending on the liquid temperature. Be sure to check the Liquid temperature – Pressure Correlation Chart.

### Model Chart

Body Material	Connection Liquid/Air	Diaphragm Material						
		Neoprene (CR)	Buna N (NBR)	EPDM	Viton® (FKM)	PTFE	Hytre® (TPEE)	Santoprene® (TPO)
Aluminum (ADC12)	Rc/Rc	AD-25AC (851778)	AD-25AN (851797)	AD-25AE (851798)	AD-25AV (851799)	AD-25AT (851758)	AD-25AH (851760)	AD-25AS (853334)
	NPT/NPT	(853328)	(853329)	(853330)	(853331)	(853332)	(853333)	(853334)
Stainless Steel (SCS14/SUS316)	Rc/Rc	AD-25SC (851786)	AD-25SN (851802)	AD-25SE (851804)	AD-25SV (851801)	AD-25ST (851765)	AD-25SH (851764)	AD-25SS (853354)
	NPT/NPT	(853335)	(853336)	(853337)	(853338)	(853339)	(853340)	(853341)
Cast Iron (S45C)	Rc/Rc	AD-25FC (851800)	AD-25FN (851799)	AD-25FE (851801)	AD-25FV (851802)	AD-25FT (851765)	AD-25FH (851764)	AD-25FS (853341)
	NPT/NPT	(853335)	(853336)	(853337)	(853338)	(853339)	(853340)	(853341)
Polypropylene (PPG)	Rc/Rc	AD-25PC (851971)	AD-25PN (853342)	AD-25PE (853344)	AD-25PV (853345)	AD-25PT (853346)	AD-25PH (851970)	AD-25PS (853348)
	NPT/NPT	(853342)	(853343)	(853344)	(853345)	(853346)	(853347)	(853348)
Kynar® (PVDF)	Rc/Rc	AD-25VC (853356)	AD-25VN (853357)	AD-25VE (853358)	AD-25VV (853359)	AD-25VT (854621)	AD-25VH (853359)	AD-25VS (853360)
	NPT/NPT	(853356)	(853357)	(853358)	(853359)	(853358)	(853359)	(853360)

**!** \* Purchaser shall not directly or indirectly, export, re-export transship or otherwise transfer this product in violation of any applicable export control laws and regulations promulgated and administered by the governments of the countries asserting jurisdiction over the parties or transaction.

## AD-40 Series (fit to NDP-40/H40)

### Specifications

Port Size		1-1/2" (40A)
Liquid	Intake	Rc1-1/2" or NPT1-1/2"
	Discharge	Rc1-1/2" or NPT1-1/2"
Air	Supply	Rc1/4" or NPT1/4"
	Exhaust	Rc1/8" w/ silencer
Air Supply Pressure		0.2 - 0.7MPa
Maximum Discharge Pressure		0.7MPa
Net Weight		AD-40A □ : 10.4kg
		AD-40S □ : 15.9kg
		AD-40F □ : 15.2kg
		AD-40P □ : 11.2kg

**!** Air supply pressure of Plastic Body Pumps is depending on the liquid temperature. Be sure to check the Liquid temperature – Pressure Correlation Chart.

### Model Chart

Body Material	Connection Liquid/Air	Diaphragm Material						
		Neoprene (CR)	Buna N (NBR)	EPDM	Viton® (FKM)	PTFE	Hytre® (TPEE)	Santoprene® (TPO)
Aluminum (ADC12)	Rc/Rc	AD-40AC (852936)	AD-40AN (853361)	AD-40AE (853362)	AD-40AV (853363)	AD-40AT (853364)	AD-40AH (853365)	AD-40AS (853367)
	NPT/NPT	(853361)	(853362)	(853363)	(853364)	(853364)	(853365)	(853367)
Stainless Steel (SCS14/SUS316)	Rc/Rc	AD-40SC (852973)	AD-40SN (852974)	AD-40SE (852975)	AD-40SV (852976)	AD-40ST (852977)	AD-40SH (852978)	AD-40SS (853372)
	NPT/NPT	(853368)	(853369)	(853370)	(853371)	(853372)	(853372)	(853372)
Cast Iron (S45C)	Rc/Rc	AD-40FC (852987)	AD-40FN (852988)	AD-40FE (852989)	AD-40FV (852990)	AD-40FT (852991)	AD-40FH (852992)	AD-40FS (853388)
	NPT/NPT	(853382)	(853383)	(853384)	(853385)	(853386)	(853387)	(853388)
Polypropylene (PPG)	Rc/Rc	AD-40PC (852981)	AD-40PN (852982)	AD-40PE (852983)	AD-40PV (852984)	AD-40PT (852985)	AD-40PH (852986)	AD-40PS (853381)
	NPT/NPT	(853375)	(853376)	(853377)	(853378)	(853379)	(853380)	(853381)
Kynar® (PVDF)	Rc/Rc	AD-40VC (1500AD)	AD-40VN (1500AD)	AD-40VE (1500AD)	AD-40VV (1500AD)	AD-40VT (1500AD)	AD-40VH (1500AD)	AD-40VS (1500AD)
	NPT/NPT	(1500AD)	(1500AD)	(1500AD)	(1500AD)	(1500AD)	(1500AD)	(1500AD)

**!** \* Purchaser shall not directly or indirectly, export, re-export transship or otherwise transfer this product in violation of any applicable export control laws and regulations promulgated and administered by the governments of the countries asserting jurisdiction over the parties or transaction.

## AD-50 Series (fit to NDP-50/H50)

### Specifications

Port Size		2" (50A)
Liquid	Intake	Rc2" or NPT2"
	Discharge	Rc2" or NPT2"
Air	Supply	Rc1/4" or NPT1/4"
	Exhaust	Rc1/8" w/ silencer
Air Supply Pressure		0.2 - 0.7MPa
Maximum Discharge Pressure		0.7MPa
Net Weight		AD-50A □ : 16.6kg
		AD-50S □ : 25.0kg
		AD-50F □ : 24.0kg
		AD-50P □ : 19.2kg
		AD-50V □ : 12.4kg

**!** Air supply pressure of Plastic Body Pumps is depending on the liquid temperature. Be sure to check the Liquid temperature – Pressure Correlation Chart.

### Model Chart

Body Material	Connection Liquid/Air	Diaphragm Material						
		Neoprene (CR)	Buna N (NBR)	EPDM	Viton® (FKM)	PTFE	Hytre® (TPEE)	Santoprene® (TPO)
Aluminum (ADC12)	Rc/Rc	AD-50AC (852994)	AD-50AN (852995)	AD-50AE (852996)	AD-50AV (852997)	AD-50AT (852998)	AD-50AH (852999)	AD-50AS (853000)
	NPT/NPT	(853393)	(853390)	(853391)	(853392)	(853393)	(853394)	(853395)
Stainless Steel (SCS14/SUS316)	Rc/Rc	AD-50SC (853001)	AD-50SN (853002)	AD-50SE (853003)	AD-50SV (853004)	AD-50ST (853005)	AD-50SH (853006)	AD-50SS (853007)
	NPT/NPT	(853396)	(853397)	(853398)	(853399)	(853400)	(853401)	(853402)
Cast Iron (S45C)	Rc/Rc	AD-50FC (853014)	AD-50FN (853015)	AD-50FE (853016)	AD-50FV (853017)	AD-50FT (853018)	AD-50FH (853019)	AD-50FS (853020)
	NPT/NPT	(853410)	(853411)	(853412)	(853413)	(853414)	(853415)	(853416)
Polypropylene (PPG)	Rc/Rc	AD-50PC (853009)	AD-50PN (853010)	AD-50PE (853011)	AD-50PV (853012)	AD-50PT (853013)	AD-50PH (853014)	AD-50PS (853015)
	NPT/NPT	(853403)	(853404)	(853405)	(853406)	(853407)	(853408)	(853409)
Kynar® (PVDF)	Rc/Rc	AD-50VC (853417)	AD-50VN (853418)	AD-50VE (853419)	AD-50VV (853420)	AD-50VT (853421)	AD-50VH (853422)	AD-50VS (853423)
	NPT/NPT	(853417)	(853418)	(853419)	(853420)	(853421)	(853422)	(853423)

**!** \* Purchaser shall not directly or indirectly, export, re-export transship or otherwise transfer this product in violation of any applicable export control laws and regulations promulgated and administered by the governments of the countries asserting jurisdiction over the parties or transaction.

## Without Pulsation Dampeners

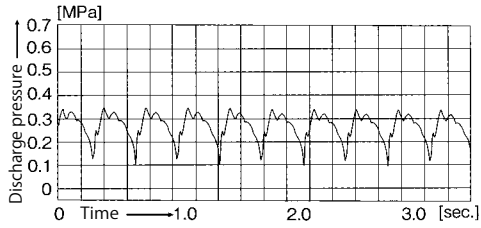

## With Pulsation Dampeners

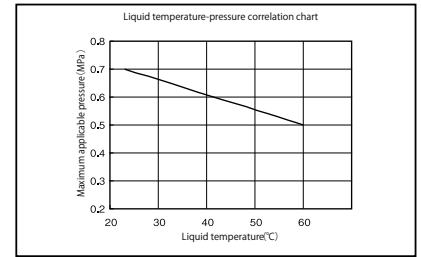
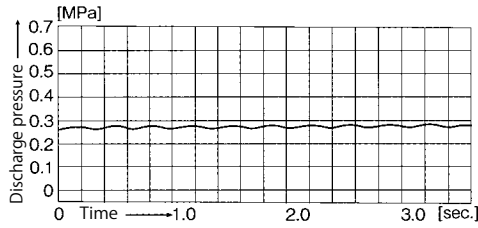

## Dimensions

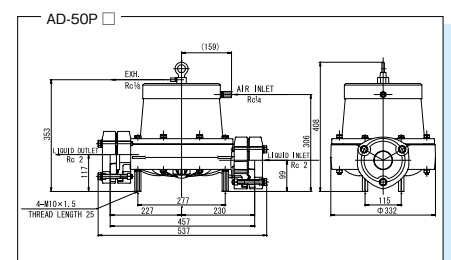
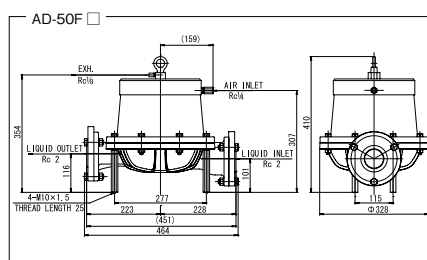
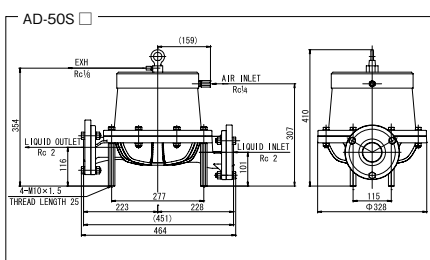
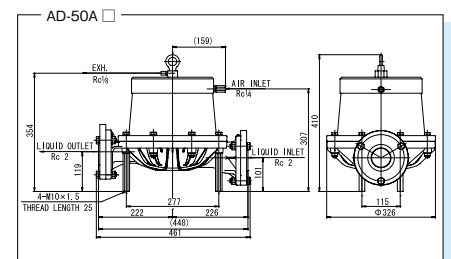
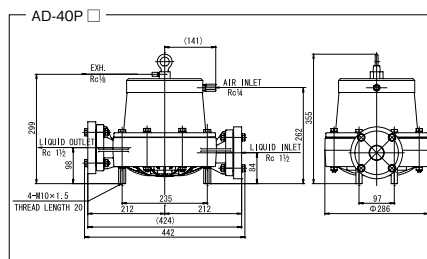
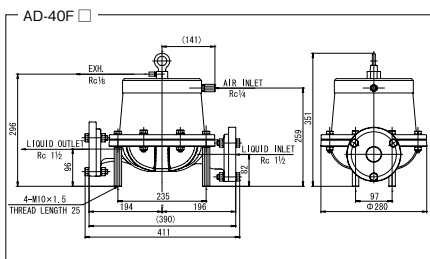
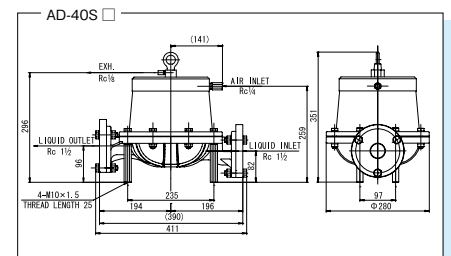
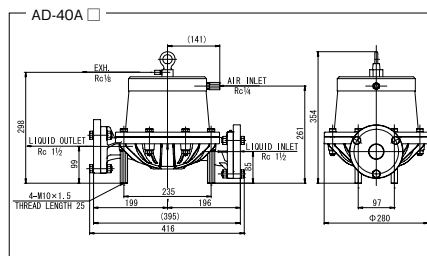
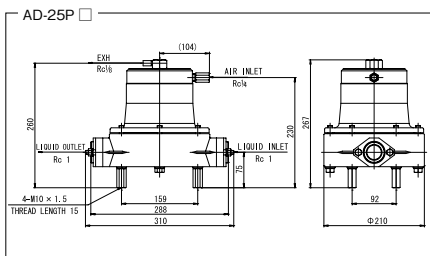
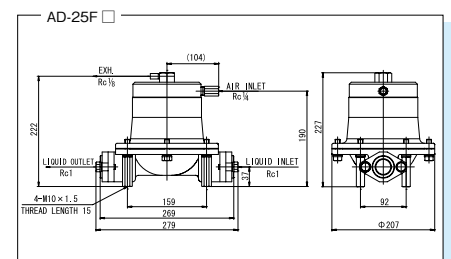
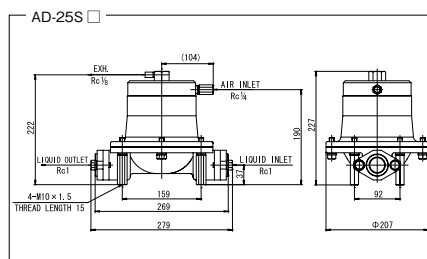
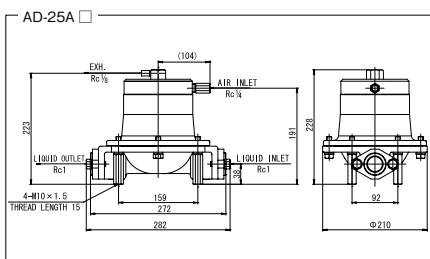
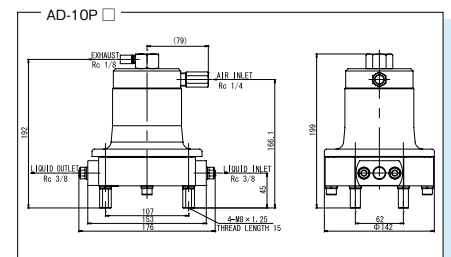
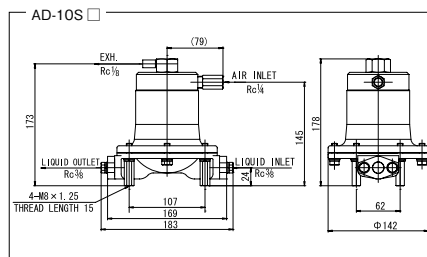
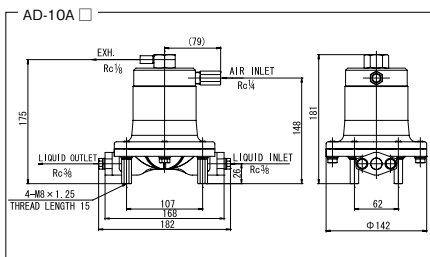

# Corrosion Resistant Chart

Diaphragm Material	C: Neoprene (CR)	N: Buna N (NBR)	E: Nordel™ (EPDM)	V: Viton® (FKM)	T: Teflon® (PTFE)	H: Hytrel® (TPEE)	S: Santoprene® (TPO)
A: Aluminum (ADC12 AC4C-T6)	Glaze Bilge waste water	Lubricant Kerosene Wax Cutting oil	Acetone solution	Ethylene alcohol Xylene Jet fuel	Latex Paint Ink	Lubricant, heavy oil, brake oil, naphtha, kerosene, mold lubricant	Acetone Bilge waste water
S: Stainless steel (SCS14 SUS316)	Ammonia water Slack lime	L.P.G Ethyl chloride Sodium peroxide	Coal slurry CMP	Methylene chloride Lactic acid Trichloroethylene	Sulfuric acid (98%) Nitric acid (less than 25%) MEK Acetone		
F: Cast iron (FC250 S45C)	Kaolin liquid Ferrite slurry Active sludge Sewage water						
P: Polypropylene (PPG)	Ferrous chloride Glaze	Whiskey Sodium silicate Methyl alcohol	Sulfuric acid (less than 20%)	Ethyl alcohol Perchloroethylene	Plating solution Photograph developing liquid Benzene Hydrogen peroxide		
V: Kynar® (PVDF)					Sodium hypochlorite		
D: Groundable Acetal (POM)	Methyl alcohol Sodium sulfate Ammonium sulfate	Ethyl alcohol Methyl alcohol Ammonium nitrate	Acetaldehyde Butylnitryl Chromic acid	Copper sulfate (II) Sodium sulfate Barium sulfate	Ammonium nitrate Barium sulfate Dimethyl ether	Ethyl alcohol Ammonium chloride Calcium chloride	Acetone Ammonia water Butyl acetate

✓ For further information, please consult Yamada or your nearest distributor.

## Installation Diagram

### Ideal Installation for Air-Operated Double Diaphragm Pump

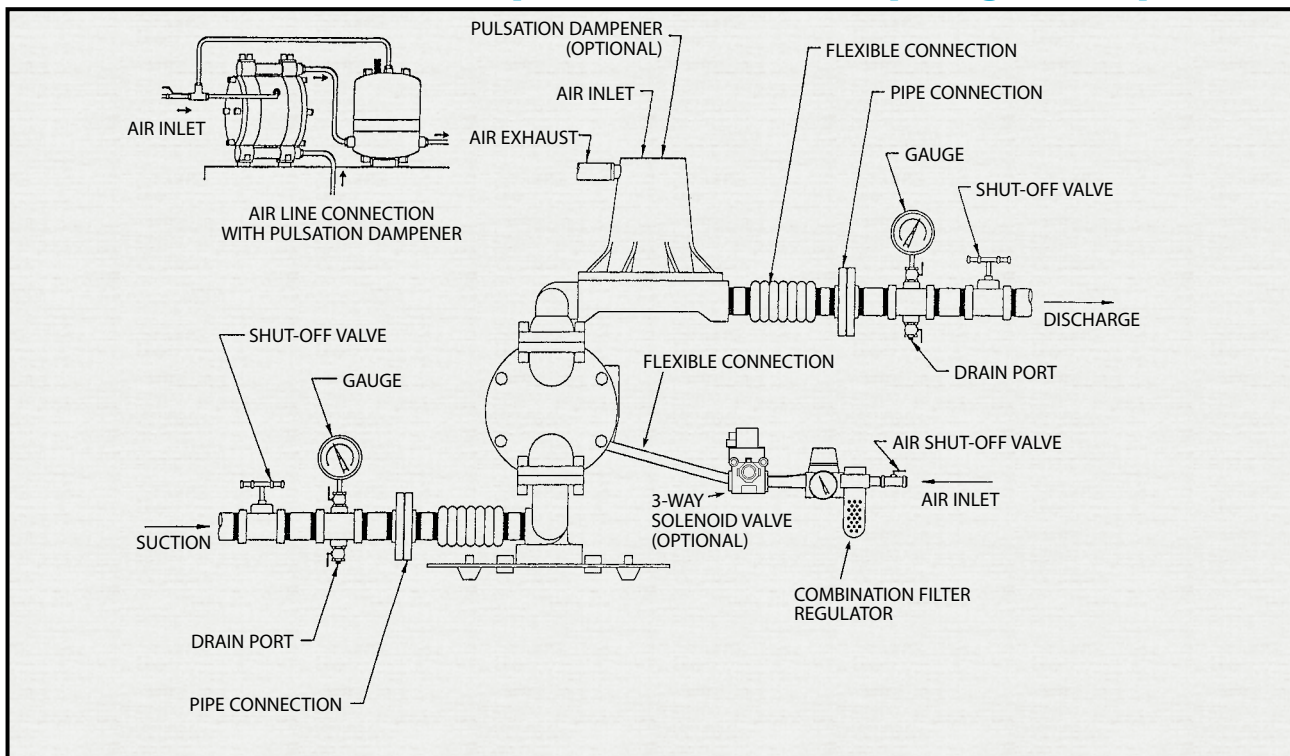

# REQUEST SHEET

## YAMADA CORPORATION

International Department  
Phone:81-(0)3-3777-0241

## FAX:81(0)3-3777-0584

For help and recommendations for pump choice and applications, please complete this form with as many details as possible.

Please send it by fax to Yamada Corporation and we will get straight back to you.

- Are you already using Yamada products ? (YES·NO)
- Have you dealt directly with Yamada Corporation in the past ?(YES·NO)
- How did you learn about Yamada Corporation. ( )

### Purpose of this request.

- Request for technical information.
- Request for quotation.
- Request to purchase products.
- Request for more information.
- Request for catalogues of flyers.
- Request for local dealer contact details.
- Other.

Company \_\_\_\_\_

Address (with Postcode): \_\_\_\_\_

Phone:( ) \_\_\_\_\_

Fax:( ) \_\_\_\_\_

Department/Section/Group: \_\_\_\_\_

Name \_\_\_\_\_

**To: YAMADA CORPORATION, International Department**

Please provide a sketch of your system including as many details as possible

1) Potential product: Model \_\_\_\_\_ Diameter \_\_\_\_\_ A

2) Objectives: \_\_\_\_\_

3) Specifications of fluid:

Name	Fluid properties	Concentration	%
Specific gravity	Viscosity	cp	Temperature °C
Slurry included?	<input type="checkbox"/> Yes / <input type="checkbox"/> No	→Concentration	Wt% Diameter mm

4) Pump output (Flow rate) Nominal rate \_\_\_\_\_ /min \_\_\_\_\_ /hr Max. rate \_\_\_\_\_ /min \_\_\_\_\_ /h

Total stroke \_\_\_\_\_ M MPa

Ambient temperature \_\_\_\_\_

5) Fluid container:  200L Drum container  20L Pail container  18L square container  
 Custom container: Specifications \_\_\_\_\_

6) Operation conditions: Outdoor /  Indoor

Operation frequency (How often do you run your pump?) Continuous / Intermittent hr/day or hr/week or hr/month

7) Air supply condition: \_\_\_\_\_ MPa

8) Number of units: \_\_\_\_\_ unit(s)

9) Expected commercial conditions \_\_\_\_\_

10) Other requirements \_\_\_\_\_



## CAUTION WHEN SELECTING A PUMP

Yamada offers a large range of Air Operated Pumps to cater for many different kinds of materials and conditions. When selecting the most appropriate pump for a particular selection and installation please consult your local Yamada Pump Distributor or Yamada Corporation.

Your Local Distributor:

### **YAMADA CORPORATION** **International Department**

No.1-3, 1-Chome, Minami-Magome,  
Ohta-ku, Tokyo 143-8504, Japan

Phone +81-(0)3-3777-0241

Fax +81-(0)3-3777-0584

E-mail: [intl@yamadacorp.co.jp](mailto:intl@yamadacorp.co.jp)

Web: [www.yamadacorp.co.jp/global](http://www.yamadacorp.co.jp/global)

Form no.:910-084E Revised: June.2014