



Lubrication Equipment

www.yamadacorp.co.jp/global

About YAMADA . . .

The Yamada Corporation has been a leading producer of industrial equipment since 1905, and of fluid handling products for over 60 years. As a leader in pneumatic pumping technology, Yamada is known in many industries worldwide for its innovative products, superior quality, and unmatched reliability. Other companies may claim to be innovators, but an impressive history of delivering new products and solving customer problems confirms Yamada's position as the industry leader.

Yamada's reputation for manufacturing top quality products, allied with continuing efforts in research and development have created a strong foundation for market leadership. As an ISO 9001 certified corporation, stringent quality procedures are followed throughout the manufacturing process, including liquid testing of every pump prior to shipping.

The Yamada Corporation is headquartered in **Tokyo** with manufacturing facilities located throughout Japan. Satellite facilities are located in **Arlington Heights, Illinois, USA**, servicing the Western Hemisphere, **The Netherlands**, providing support throughout Europe, Africa, and the Middle East, and **Shanghai**, covering the emerging markets of China. These offices are support centers for over 300 authorized fully stocking Yamada distributors worldwide.

Yamada professional staff provides:

- Customer Service
- Product Training
- Research & Development
- Parts and Service for all Yamada® Pumps
- Application Engineering
- Industry Knowledge

With over 300 distributors, Yamada is effectively positioned to service your market needs. Contact Yamada for the location of your closest local stocking distributor.

For additional information, AutoCAD® drawings, product literature, and promotions, please visit yamadacorp.co.jp/global or contact our Sales Staff at Phone No.+81-(0)3-3777-0241.

CONTENTS

| | |
|--|----|
| Hand Grease Guns | 1 |
| Electric Driven/Air Operated Grease Guns | 2 |
| Extensions | 3 |
| Bellows Cartridge Greases | 4 |
| Hand-Operated Oil Pumps | 5 |
| Hand-Operated Oil Pumps | 6 |
| Hand-Operated Grease Pumps | 7 |
| Air-Operated Oil Lubricators | 8 |
| Air-Operated Grease Lubricators | 9 |
| Electric Driven Grease Lubricators | 10 |
| Air-Operated Oil Transfer Pumps | 11 |
| Air-Operated Oil Transfer Pumps | 12 |
| Air-Operated Grease Transfer Pumps | 13 |
| Compact Reel YR Series | 14 |
| Hose Reel HR Series | 15 |
| Control Valves | 16 |

Pump Selection Guide

Pump Ratio

The pump ratio is the ratio between the effective areas of the air motor (A) and of the lower pump (B). Where the area (B) is usually indicated as the base (i.e., as 1). For example when A is 100cm² and B is 20cm² the pump ratio would be 100:20 or 5 times 1, (=5:1). This ratio is one of the most important factors determining pump characteristics.

The maximum (theoretical) outlet discharge pressure can be calculated by multiplying the pump ratio by the supplied air pressure. For example if the above pump with a 5:1 ratio is used with an air supply of 0.7 MPa, then the maximum discharge pressure would be 3.5MPa, (= 7 times 5). By using pumps with different pump ratios even with the same inlet air pressure it is possible to achieve low to extremely high discharge pressure.

The Yamada line up of Air Powered™ Pumps covers all ranges of pump ratio from a 1:1 to 60:1. Therefore from the same 0.7MPa air supply, it's possible to achieve up to 42MPa of outlet pressure. In general the pump required often depends on the viscosity of the material. To pump very high viscosity materials, a pump with a high pump ratio is required.

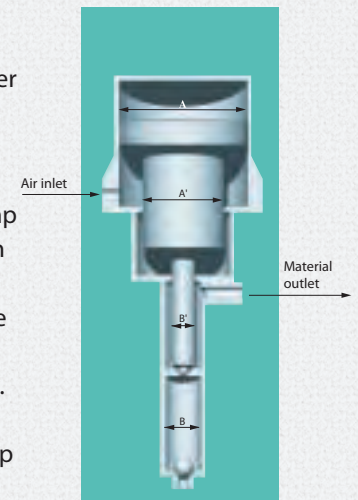

REMARKS

POWER SOURCES



Compressed Air



Manual



AC 100V



AC 240V



DC 24V or
Other Battery

SUITABLE MATERIAL FOR USE



Oil



NLGI No.0 Grease



NLGI No.1 Grease



NLGI No.2 Grease



Water or
Hot Water

SUITABLE CONTAINER



18L(16kg) Pail



200L(180kg) Drum

METHODS OF LOADING



Direct-filling



420mL
Bellows Cartridge



210mL
Bellows Cartridge

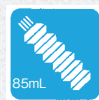

85mL
Bellows Cartridge



400g
DIN1284 Cartridge

Pump Selection Guide

Standards of Grease

■ Spray
 ■ Manual/Pump
 ■ Air/Pump
 ■ Pressure supply pump

| Consistency of Grease | | | | |
|-----------------------|---------|------------------------------------|--------------------|--|
| NLGI No. | JIS No. | ASTM Consistency (25°C and 60W) | Appearance | Supplying method |
| Nº 000 | 000 | 445~475 | Semi-fluid | ■ |
| Nº 00 | 00 | 400~430 | // | ■ ■ ■ |
| Nº 0 | 0 | 355~385 | Semi-fluid or Soft | ■ ■ ■ |
| Nº 1 | 1 | 310~340 | Soft | ■ ■ ■ |
| Nº 2 | 2 | 265~295 | Standard | ■ ■ ■ |
| Nº 3 | 3 | 220~250 | Standard | ■ ■ |
| Nº 4 | 4 | 175~205 | Semi-firm | ■ |
| Nº 5 | 5 | 130~160 | firm | Please Consult Yamada. |
| Nº 6 | 6 | 85~115 | Solid | |

Standard Size of Containers

18kg Pail

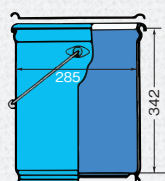

Open Head Straight Pail

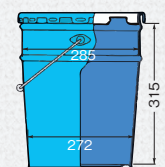

Open Head Tapered Pail

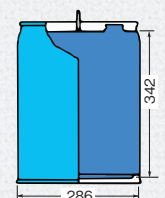

Tight Head Pail

55kg Drum

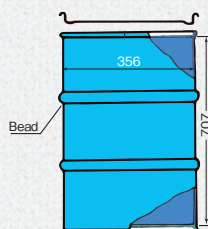

Open Head Drum

180kg Drum

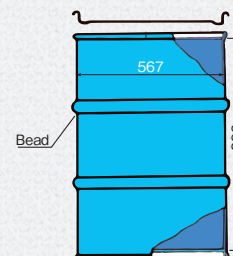

Open Head Drum

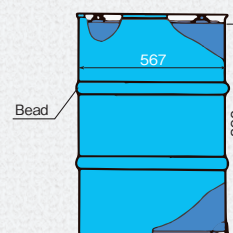

Tight Head Drum

Pump Selection Guide

Viscosity

Oil Grade Systems

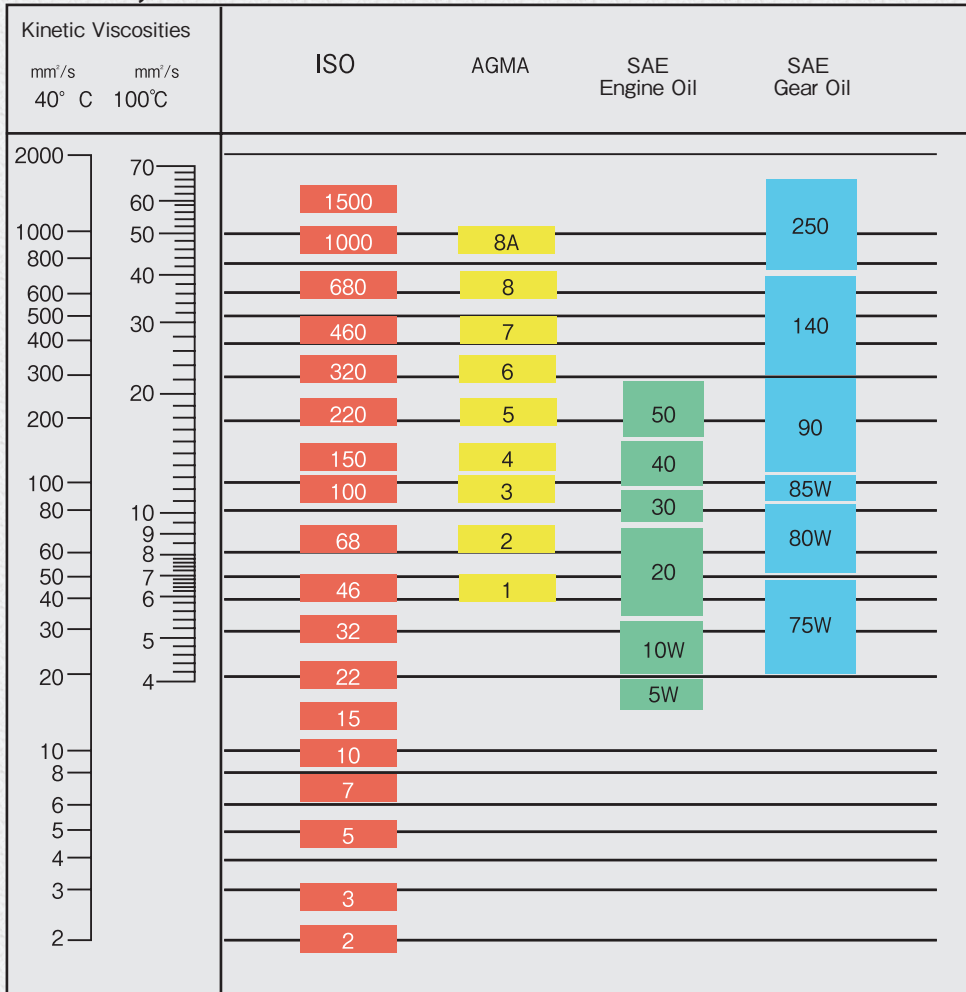

Reference

| Material | Viscosity at 20°C (CPS) | Material | Viscosity at 20°C (CPS) |
|---------------------|-------------------------|---|-------------------------|
| Water | 1 | Gear oil | 2200~30000 |
| Turpentine | 1 | Syrup (Thin) | 2500 |
| Sulfuric acid | 2 | Syrup (Thick) | 3200 |
| Milk | 3 | Maximum viscosity of self-suction limit | |
| Light oil, Kerosene | 4 | Grease (#0) | 20000※ |
| Ethylene glycol | 16 | Grease (#1) | 30000※ |
| Crude oil | 28 | Mayonnaise | 60000 |
| Boiled oil | 64 | Vaseline | 64000 |
| Motor oil SAE20 | 125 | Grease (#2) | 70000※ |
| Motor oil SAE30 | 200 | Mustard | 70000 |
| Castor oil | 240 | Grease (#3) | 100000※ |
| Motor oil SAE40 | 319 | Tomato paste | 190000 |
| Gear oil 80 | 240~1900 | Peanut butter | 250000 |
| Gear oil 90 | 590~5100 | | |

※This number is apparent viscosity.

Grease Guns

Hand Grease Guns

YAMADA is offering high quality, high performance and durable hand grease guns.

Select the best model for your needs depending on size, capacity, grease loading method, etc.

All grease guns are equipped with straight steel extension or 3-jaw steel extension as standard.

854655 KH-16



- Compact size pistol type grease gun with 3-jaw steel extension (CNP-2)
- Barrel with lipped follower for use with 140mL direct-filling or 85mL Bellows Cartridge

854629 KH-120



- Compact size light-weight grease gun with straight steel extension
- Barrel with lipped follower for use with 140mL direct-filling or 85mL Bellows Cartridge

854628 KH-32



- Small size grease gun with straight steel extension
- Barrel with lipped follower for use with 200mL direct-filling

854627 KH-35



- Medium size hand grease gun with straight steel extension
- Barrel with lipped follower for use with 400mL direct-filling or 210mL Bellows Cartridge

854626 CH-400



- Standard size grease gun with straight steel extension
- Barrel with non-lipped follower for use with 420mL Bellows Cartridge

854669 KH-500

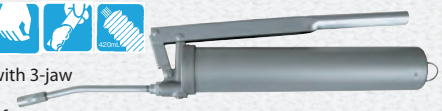

- Standard size grease gun with 3-jaw steel extension (CNP-2)
- Barrel with lipped follower for use with 500mL direct-filling or 420mL Bellows Cartridge

854787 CH-650LL



- Standard size high-pressure grease gun with 3-jaw steel extension (CNP-2)
- Ergonomic rubber grip on lever handle for comfortable use
- Barrel with lipped follower for use with 500mL direct-filling or 420mL Bellows Cartridge

854654 GC-57K



- Standard size grease gun with 3-jaw steel extension (CNP-2)
- Barrel with lipped follower for use with 500mL direct-filling or 400g DIN1284 Cartridge

Specifications

| Model No. | Model | Length* (mm) | Extension | Weight* (kg) | Barrel Dia. (mm) | Barrel Capacity (mL) | Cartridge (mL) | Discharge per Stroke (mL) | Max Discharge Pressure (MPa) |
|-----------|----------|--------------|-----------|--------------|------------------|----------------------|-----------------|---------------------------|------------------------------|
| 854655 | KH-16 | 241 | CNP-2 | 0.44 | 38.0 | 140 | 85 | 0.4 | 10 |
| 854629 | KH-120 | 232 | HSP-1 | 0.51 | 38.0 | 140 | 85 | 0.6 | 20 |
| 854627 | KH-35 | 290 | HSP-1 | 1.11 | 59.6 | 400 | 210 | 1.0 | 25 |
| 854628 | KH-32 | 412 | HSP-1 | 1.27 | 59.6 | 200 | ---- | 1.6 | 25 |
| 854669 | KH-500 | 368 | CNP-2 | 1.30 | 59.6 | 500 | 420 | 1.0 | 50 |
| 854626 | CH-400 | 368 | HSP-2 | 1.29 | 59.6 | ---- | 420 | 1.0 | 50 |
| 854787 | CH-650LL | 401 | CNP-1 | 1.30 | 59.6 | 550 | 420 | 1.0 | 80 |
| 854654 | GC-57K | 371 | CNP-2 | 1.55 | 59.6 | 500 | DIN 1284 (400g) | 1.0 | 50 |

*Extension is not included

Dimensions

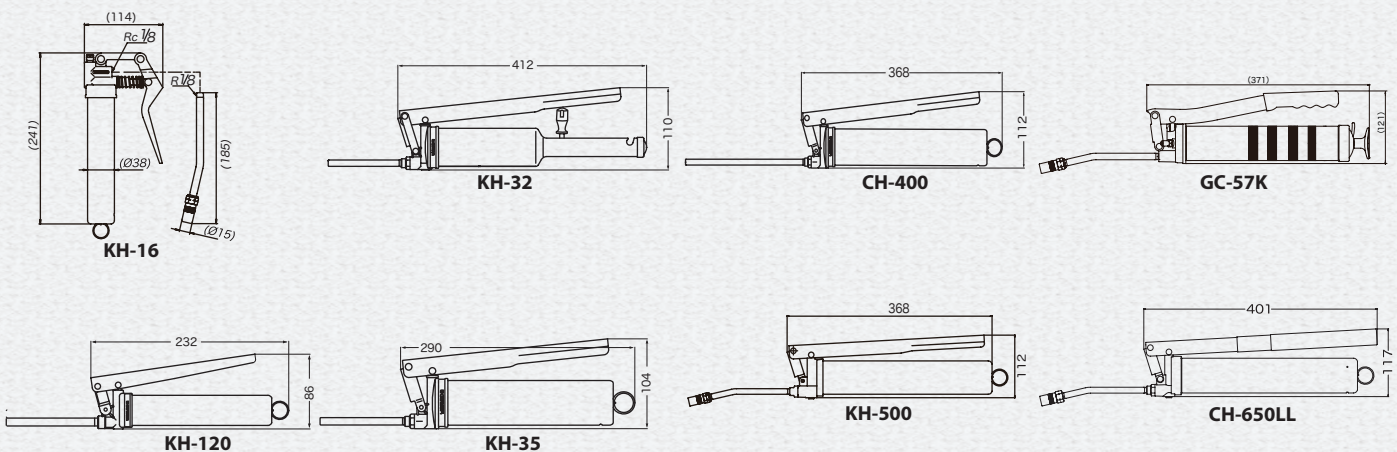

Electric Driven Grease Guns

AC100V electric and DC24V battery operated hand held grease guns.
All models are only available with 420mL Bellows Cartridge.



852443 EG-400A



852441 EG-400D



852216 EG-400B

Specifications

| Model No. | Model | Cartridge (mL) | Extension | Max Discharge Pressure (MPa) | Discharge Volume | Power Source | Power Rating (W) | Weight (kg) |
|-----------|-----------|----------------|-----------|------------------------------|---------------------------------|--------------------------|------------------|-------------|
| 852443 | EG-400A | 420 | CNP-1 | 40 | 1.6mL/sec or above at 6MPa load | AC100V | 240 | 2.7 |
| 852441 | EG-400D | | | 32 | 1.6mL/sec or above at 6MPa load | DC24V | 430 | 2.7 |
| 852216 | EG-400B*1 | | | 32 | 1.6mL/sec at 6MPa load | 2.0mL/sec at 0.5MPa load | DC9.6V | ----- |

*1 Battery Charger EG-1414-Y and Battery EG-9002-Y is equipped as standard

*2 Exclude battery

Battery Charger Specifications

| Model No. | Model | Power Source | Frequency (Hz) | Capacity (VA) | Voltage (V) | Current (A) | Charging Time |
|-----------|-----------|--------------|----------------|---------------|-------------|-------------|----------------|
| 684741 | EG-1414-Y | AC100V | 50/60 | 105 | DC7.2-14.4 | DC2.6 | Approx 45 min. |

Optional Accessories

| Model No. | Model | Description | Fits model |
|-----------|-----------|--------------------------|------------|
| 802039 | BC-165D | Extension Power Cord 15M | EG-400D |
| 684741 | EG-1414-Y | Battery Charger (AC100V) | EG-400B |
| 683877 | EG-9002-Y | Battery | EG-400B |

Dimensions

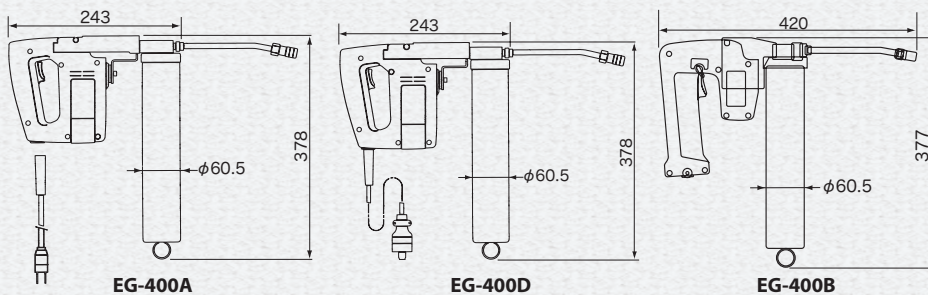

Air Operated Grease Guns

Grease flows continuously with press of the trigger.
Only available with 420mL Bellows Cartridge.



853755 AMG-400

Dimensions

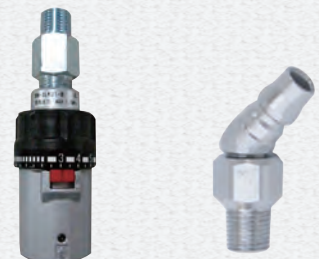
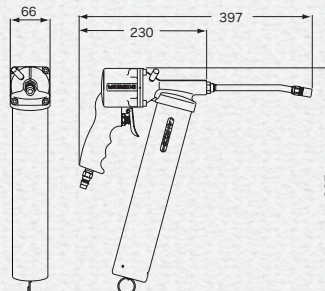

804918 AMG-AR 685472 AMG-RP

Battery Charger Specifications

| Model No. | Model | Cartridge (mL) | Extension | Max Discharge Pressure (MPa) | Max Discharge Volume (mL/min) | Supply Air Pressure (MPa) | Weight (kg) |
|-----------|---------|----------------|-----------|------------------------------|-------------------------------|---------------------------|-------------|
| 853755 | AMG-400 | 420 | CNP-2 | 32 | 280 | 0.2-0.7 | 1.8 |

Optional Accessories

| Model No. | Model | Description | Fits model |
|-----------|--------|-----------------|------------|
| 804918 | AMG-AR | Air Regulator | AMG-400 |
| 685472 | AMG-RP | Swivel Air Plug | AMG-400 |

Extensions

Optional steel and flexible extensions for grease fittings are available. These can fit to all Hand Grease Guns.

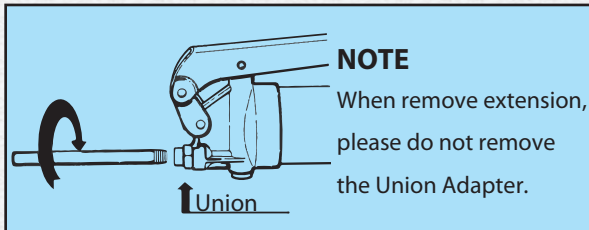

Grease Fittings

JIS B 1575



Hydraulic Fitting
Most common fitting.



Pin Type Fitting

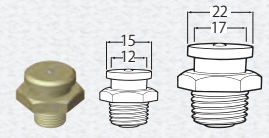

Button Head Fitting
Normal size and large size are available



Specifications

| Type | Model No. | Model | Length(mm) | Weight(g) | Usable Grease Fitting | Remark |
|---------------------------------------|-----------|-----------|------------|-----------|--------------------------------|--------------------------|
| Straight Steel Extension | 804903 | HSP-1 | 120 | 46 | Hydraulic Fitting | Nozzle O.D. 1.5mm |
| | 804904 | HSP-2 | 240 | 96 | | |
| | 804909 | HSP-3 | 135 | 56 | | |
| | 804907 | HSP-10 | 450 | 188 | | |
| Steel Extension with 3-jaw Coupler | 804910 | CNP-1 | 185 | 93 | Hydraulic Fitting | O.D. 17mm |
| | 686445 | CNP-1H | 38.5 | 37 | | 3-jaw Coupler for CNP-1 |
| | 804911 | CNP-2 | 185 | 93 | | O.D. 15mm |
| | 686446 | CNP-2H | 39 | 37 | | 3-jaw Coupler for CNP-2 |
| | 804912 | CNP-13 | 335 | 180 | | O.D. 15mm |
| Flexible Extension with 3-jaw Coupler | 850664 | SPK-1C | 355 | 141 | Pin Type Fitting | |
| | 850665 | SPK-2C | 375 | 180 | Button Head Fitting | |
| | 850666 | SPK-3C | 330 | 83 | Hydraulic Fitting | |
| | 850478 | SPK-1C-1M | 1069 | 189 | Pin Type Fitting | |
| | 850479 | SPK-2C-1M | 1070 | 242 | Button Head Fitting | |
| Normal Operating Pressure: 21MPa | 850480 | SPK-3C-1M | 1030 | 132 | Hydraulic Fitting | |
| | 850392 | SPK-5 | 418 | 300 | Hydraulic Fitting | Extension for CNP Series |
| | 850381 | SPK-20C | 377 | 320 | Large size Button Head Fitting | |
| | 851268 | SPK-700E | 705 | 160 | Hydraulic Fitting | |

Dimensions

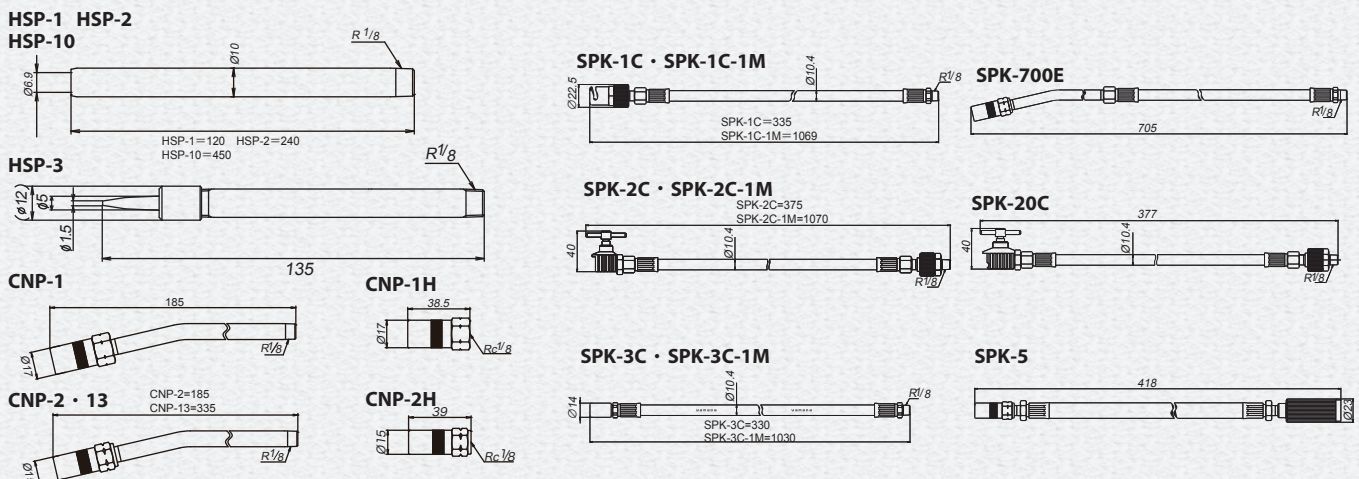

Bellows Cartridge Greases

YAMADA Bellows Cartridge Grease is reputed as clean, convenient and economical cartridge grease, which is long-selling product in Japan.

With the tightly-sealed bellows, contamination and air-pocket can be eliminated.

By the screw cap, the cartridge change is possible in the middle of use.

General Purpose Greases

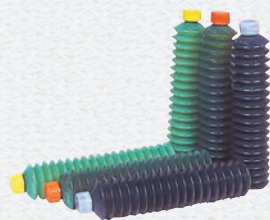

MMG-80 Series



MMG-200 Series



MMG-400 Series

Dimensions

M15x2.5

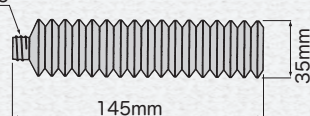

M15x2.5

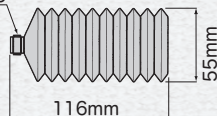

M15x2.5

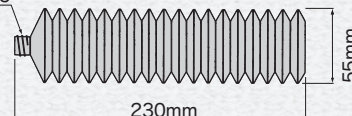

Specifications

| Capacity, Qty per Carton Box | Model No. | Model | Grease Type | NLGI No. | ASTM Value | Temp Range | Fits model |
|------------------------------|-----------|-----------|-------------|----------|------------|---------------|--|
| 420mL, 20pcs | 682314 | MMG-400MP | Lithium | No.2 | 265-295 | -15°C - 130°C | KH-500, CH-400, CH-650LL, EG-400A, EG-400D, EG-400B, AMG-400 |
| | 682313 | MMG-400CG | Chassis | No.1 | 310-340 | -10°C - 80°C | |
| | 682312 | MMG-400MO | Molybdenum | No.2 | 265-295 | -15°C - 150°C | |
| 210mL, 20pcs | 683311 | MMG-200MP | Lithium | No.2 | 265-295 | -15°C - 130°C | KH-35 |
| | 683312 | MMG-200CG | Chassis | No.1 | 310-340 | -10°C - 80°C | |
| 85mL, 30pcs | 682593 | MMG-80MP | Lithium | No.2 | 265-295 | -15°C - 130°C | KH-16, KH-120 |
| | 683309 | MMG-80CG | Chassis | No.1 | 310-340 | -10°C - 80°C | |
| | 683310 | MMG-80MO | Molybdenum | No.2 | 265-295 | -15°C - 150°C | |

Grease Characteristics

| Grease Type | Features | Applications | Color of Cap | Color of Bellows |
|------------------------|--|---|--------------|------------------|
| Lithium Grease (MP) | Extreme-pressure, Water-resistant, Heat-resistant, High durability | Bearings for industrial equipment, automobiles, construction equipment and conveyor | Yellow | Green |
| Chassis Grease (CG) | Extreme-pressure, Water-resistant | Chassis of automobiles, construction equipment, conveyor and agricultural equipment | Orange | |
| Molybdenum Grease (MO) | Molybdenum-added, Extra high-pressure, Extra high-durability | Construction equipment, joints, bearings, the part on which needs high-pressure and heating | White | |

High Temp and Food Grade Greases

NPC-AA



FDL-FF20



Dimensions

M15x2.5

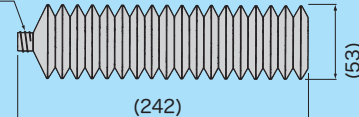

Specifications

| Capacity, Qty per Carton Box | Model No. | Model | Grease Type | NLGI No. | ASTM Value | Temp Range | Fits model |
|------------------------------|-----------|----------|------------------|----------|------------|-------------|--|
| 420mL, 20pcs | 684200 | NPC-AA | Urea | No.2 | 265-295 | -20°C-180°C | KH-500, CH-400, CH-650LL, EG-400A, EG-400D, EG-400B, AMG-400 |
| | 685800 | FDL-FF20 | Aluminum Complex | No.2 | 265-295 | -20°C-180°C | |
| 420mL, 5pcs | 685801 | FDL-FF5 | | | | | |

Grease Characteristics

| Grease Type | Features | Applications | Color of Cap | Color of Bellows |
|-----------------------|----------------------------------|--|--------------|------------------|
| Urea Grease (AA) | Extra high-temperature | Equipment for heavy industry, paper industry, cement industry, and any other application that require high heat resistance and long life | White | Green |
| Aluminum Complex (FF) | Meets the requirements by NSF-H1 | Food industry | | White |

Hand-Operated Oil Pumps

Oil Bucket Pumps EXS Series

Ready-to-assemble economical series.

The small package can reduce shipping cost.

Installation

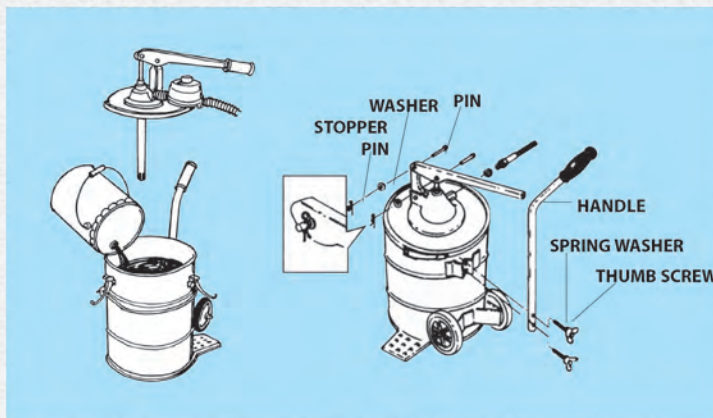

880626 STB-60EXS



880627 STB-70EXS

Dimensions

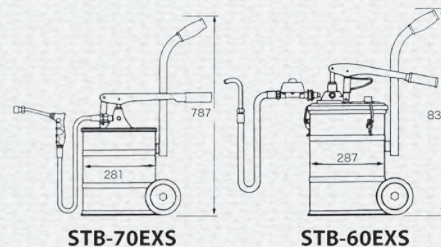

STB-70EXS

STB-60EXS

Specifications

| Model No. | Model | Capacity (L) | Discharge Volume per Cycle (mL) | Stroke Length (mm) | Weight (kg) | Accessories |
|-----------|-----------|--------------|---------------------------------|--------------------|-------------|--|
| 880626 | STB-60EXS | 20 | 40.0 | 50.0 | 10.4 | 802823 STB-2MW Hose Nozzle Assy 2M (Vynil).....1 851942 STB-M Oil Meter.....1 |
| 880627 | STB-70EXS | | | | 9.0 | 802823 STB-2MW Hose Nozzle Assy 2M (Vynil).....1 |

Oil Bucket Pumps

Please select suitable model depending on by the presence or absence of S-20 Dolly and STB-M Oil Meter.



880134 STB-50



880135 STB-60



880136 STB-70

Installation



Dimensions

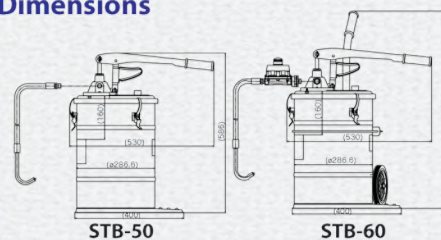

STB-50

STB-60

Specifications

| Model No. | Model | Capacity (L) | Discharge Volume per Cycle (mL) | Stroke Length (mm) | Weight (kg) | Accessories |
|-----------|--------|--------------|---------------------------------|--------------------|-------------|--|
| 880134 | STB-50 | 20 | 40.0 | 50.0 | 7.3 | 695453 STB-2MB Hose Nozzle Assy 2M (Rubber).....1 |
| 880135 | STB-60 | | | | 10.4 | 695453 STB-2MB Hose Nozzle Assy 2M (Rubber).....1 851003 S-20 Dolly.....1 851942 STB-M Oil Meter.....1 |
| 880136 | STB-70 | | | | 9.2 | 695453 STB-2MB Hose Nozzle Assy 2M (Rubber).....1 851003 S-20 Dolly.....1 |

Optional Accessories

| Model No. | Model | Description | Fits Model |
|-----------|----------|------------------------------|------------------------|
| 851003 | S-20 | Dolly | STB-50, STB-60, STB-70 |
| 851942 | STB-M | Flow Meter | STB-50, STB-60, STB-70 |
| 695453 | STB-2MB | Hose Nozzle Assy 2M (Rubber) | STB-50, STB-60, STB-70 |
| 802823 | STB-2MVV | Hose Nozzle Assy 2M (Vynil) | STB-60EXS, STB-70EXS |



851003 S-20



851942 STB-M

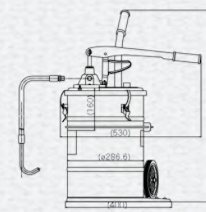

STB-70

Hand Oil Suction Guns

Simple syringe pump for oil.

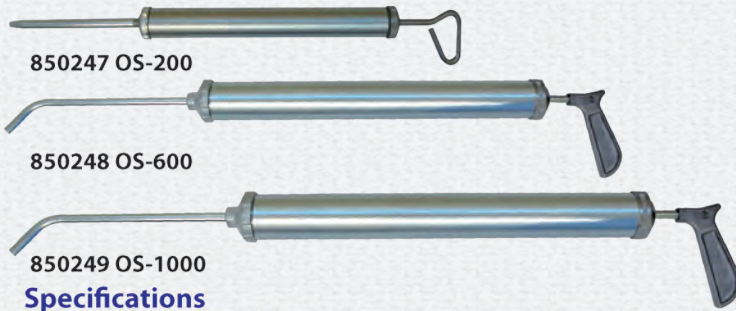

850247 OS-200

850248 OS-600

850249 OS-1000

Specifications

| Model No. | Model | Length (mm) | Weight (kg) | Capacity (mL) |
|-----------|---------|-------------|-------------|---------------|
| 850247 | OS-200 | 490 | 0.57 | 200 |
| 850248 | OS-600 | 696 | 1.28 | 600 |
| 850249 | OS-1000 | 886 | 1.77 | 1000 |

Dimensions

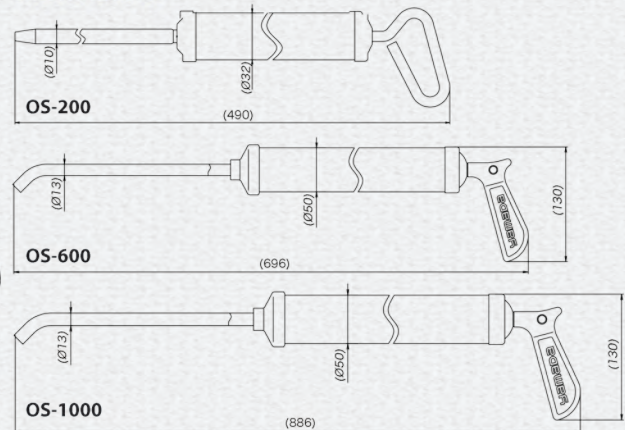

Oil Pail Pump

Simple pump that can be mounted on commercially available 20L pail. Oil meter STB-M can be mounted.



880571 HOP-20

Specifications

| Model No. | Model | Discharge Volume per Cycle (mL) | Stroke Length (mm) | Weight (kg) | Accessories |
|-----------|--------|---------------------------------|--------------------|-------------|--|
| 880571 | HOP-20 | 60.0 | 110.0 | 1.9 | 802823 STB-2MW Hose Nozzle Assy 2M (Vynil).....1 851676 S-10N Dolly.....1 |

Dimensions

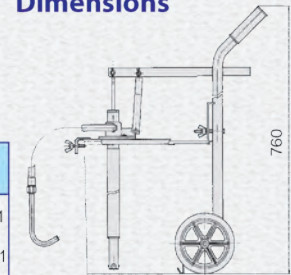

Oval Shape Oil Bucket Pumps

Small size and durable oval shape bucket pump. Suitable for field lubrication work.



880318 LPO-50

Specifications

| Model No. | Model | Discharge Volume per Cycle (mL) | Weight (kg) | Accessories |
|-----------|--------|---------------------------------|-------------|--|
| 880318 | LPO-50 | 40.0 | 8.8 | 802823 STB-2MW Hose Nozzle Assy 2M (Vynil).....1 |

Dimensions

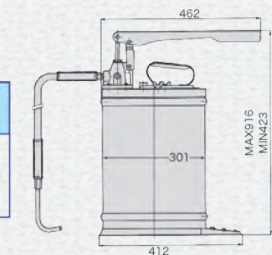

High Viscosity Oil Pumps



880132 VO-8

Compact size bucket pump

880133 VO-50

Small size oval shape bucket pump

Specifications

| Model No. | Model | Discharge Volume per Cycle (mL) | Weight (kg) | Accessories |
|-----------|-------|---------------------------------|-------------|--|
| 880132 | VO-8 | 20.0 | 5.0 | 695056 VO8-1M 1/4 x 1m Hose.....1 800772 VO8-15 Button Head Coupler.....1 |
| 880133 | VO-50 | 24.0 | 9.6 | 695055 VO50-1.5M 3/8 x 1.5m Hose.....1 800894 VO50-15 Button Head Coupler.....1 |

Dimensions

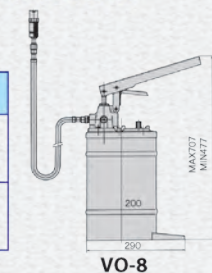

VO-8

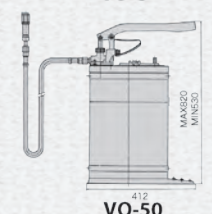

VO-50

Optional Accessories

800772 VO8-15

Button Head Coupler for VO-8



800894 VO50-15

Normal Size Button Head Coupler for VO-50



800628 VO50-22

Large Size Button Head Coupler for VO-50



Hand-Operated Grease Pumps

Grease Bucket Pump EXS Series

Ready-to-assemble economical series. The small package can reduce shipping cost.



880624 SK-77EXS

Installation

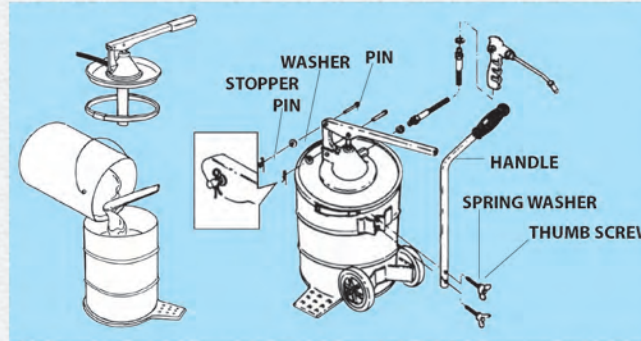

Dimensions

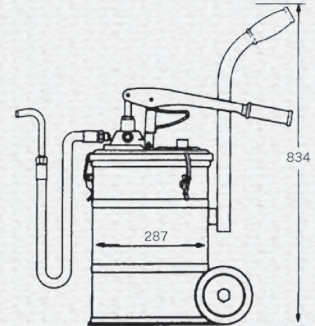

Specifications

| Model No. | Model | Capacity (L) | Discharge Pressure (MPa) | Discharge Volume per Stroke (g) | Stroke Length (mm) | Weight (kg) | Accessories |
|-----------|----------|--------------|--------------------------|---------------------------------|--------------------|-------------|--|
| 880624 | SK-77EXS | 20 | 25.0 | 3.2 | 38-43 | 9.6 | 800601 SK-G Grease Nozzle.....1 695046 SK-2M Grease Hose 2M.....1 |

Grease Bucket Pump

Follower plate is equipped with SK-55 and SK-77 as standard. Compact SK-8 is suitable for filed lubrication work.



880307 SK-55



880308 SK-77



880276 HPG-50



880194 SK-8

Specifications

| Model No. | Model | Capacity (L) | Discharge Pressure (MPa) | Stroke Length (mm) | Weight (kg) | Accessories |
|-----------|--------|--------------|--------------------------|--------------------|-------------|--|
| 880307 | SK-55 | 20 | 25.0 | 50.0 | 9.6 | 800601 SK-G Grease Nozzle.....1 695046 SK-2M Grease Hose 2M.....1 801426 Follower Plate.....1 |
| 880308 | SK-77 | 20 | 25.0 | 50.0 | 9.6 | 800601 SK-G Grease Nozzle.....1 695046 SK-2M Grease Hose 2M.....1 801426 Follower Plate.....1 851003 S-20 Dolly.....1 |
| 880194 | SK-8 | 10 | 25.0 | — | 6 | 800601 SK-G Grease Nozzle.....1 695046 SK-2M Grease Hose 2M.....1 |
| 880276 | HPG-50 | 10 | 25.0 | — | 9 | 695271 Grease Hose 1.5M.....1 804911 CNP-2 Steel Extension.....1 |

Optional Accessories

| Model No. | Model | Description | Fits Model |
|-----------|-------|--------------------------|------------------------------|
| 851003 | S-20 | Dolly | SK-55, SK-77 |
| 695046 | SK-2M | Grease Hose 2M Max 18MPa | SK-55, SK-77, SK-77EXS, SK-8 |
| 695100 | SK-3M | Grease Hose 3M Max 18MPa | SK-55, SK-77, SK-77EXS, SK-8 |
| 695102 | SK-5M | Grease Hose 5M Max 18MPa | SK-55, SK-77, SK-77EXS, SK-8 |

Installation

When refilling the standard grease container.

When fitting to other kinds of grease pail (except SK-8 and HPG-50).

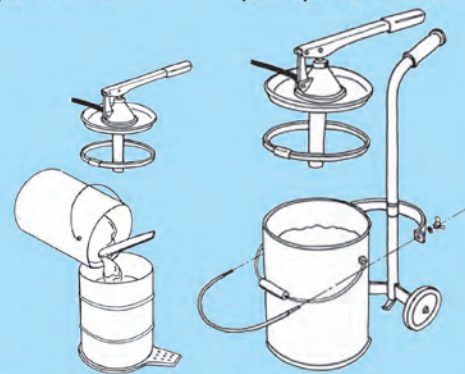

Dimensions

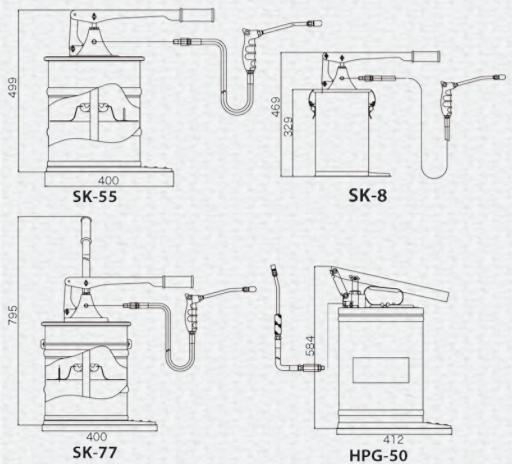

851003 S-20



Replacement Hoses

Air-Operated Oil Lubricators

Standard SGR-55 and high volume, high pressure SGR110A5 are available. SGR110A5 is equipped with float-type oil level gauge and mechanical oil flow meter with non-drip flexible extension as a standard.



880267 SGR-55



880635 SGR110A5

Dimensions

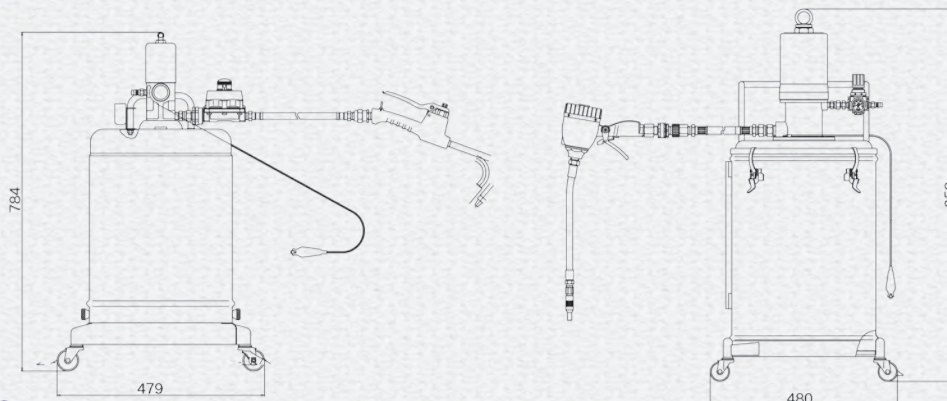

Specifications

| Model No. | Model | Capacity (L) | Pump Ratio | Max Discharge Pressure (MPa) | Max Discharge Volume (L/min) | Max Air Consumption(NL/min) | Weight (kg) | Accessories |
|-----------|----------|---------------------------|------------|------------------------------|------------------------------|-----------------------------|-------------|---|
| 880267 | SGR-55 | 20 (Attached pail can) | 1.8:1 | 1.2 | 7.0 | 200 | 17.0 | 850792 SGR-55PA Oil Transfer Pump.....1 850206 SGR-5TG Oil Dispense Gun.....1 695052 SGR-55-1.5M Oil Hose 1.5M.....1 851942 STB-M Oil Meter.....1 682905 Pail Can.....1 680743 PS-20PM Air Coupler Plug.....1 |
| 880635 | SGR110A5 | 50 | 5:1 | 3.5 | 11.0 | 390 | 27.5 | 851755 PD110A5 Oil Transfer Pump.....1 801428 LBM-G Lube Mechanical Meter.....1 801195 NDN-H Flexible Extension.....1 804553 OIL-SJ Swivel Joint.....1 695700 110H-3M Oil Hose 3M.....1 802553 AR-110A Air Regulator w/ Air Plug.....1 |

Optional Accessories

| Model No. | Model | Description | Fits Model |
|-----------|-------------|------------------------|------------|
| 695052 | SGR-55-1.5M | Oil Hose 1.5M Max 7MPa | SGR-55 |
| 695051 | SGR-55-2M | Oil Hose 2M Max 7MPa | SGR-55 |
| 695103 | SGR-55-3M | Oil Hose 3M Max 7MPa | SGR-55 |
| 695154 | SGR-55-5M | Oil Hose 5M Max 7MPa | SGR-55 |
| 695866 | 110H-1M | Oil Hose 1M Max 7MPa | SGR110A5 |
| 695092 | 110H-2M | Oil Hose 2M Max 7MPa | SGR110A5 |
| 695700 | 110H-3M | Oil Hose 3M Max 7MPa | SGR110A5 |
| 695156 | 110H-5M | Oil Hose 5M Max 7MPa | SGR110A5 |



Replacement Hoses

Air-Operated Grease Lubricators

Air-Operated Grease Lubricators. Available with 16kg pail.



880870 SKR-55



880877 SKR-66

Dimensions

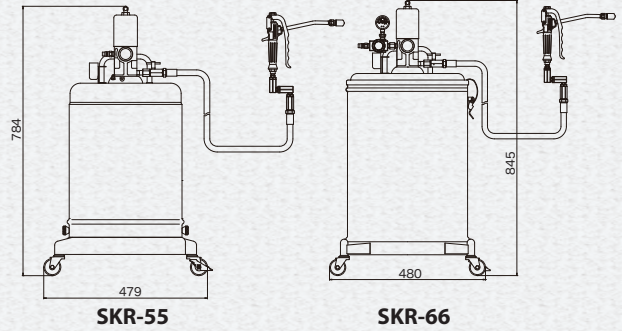

880631 SKR-110A50



880873 KPL-55

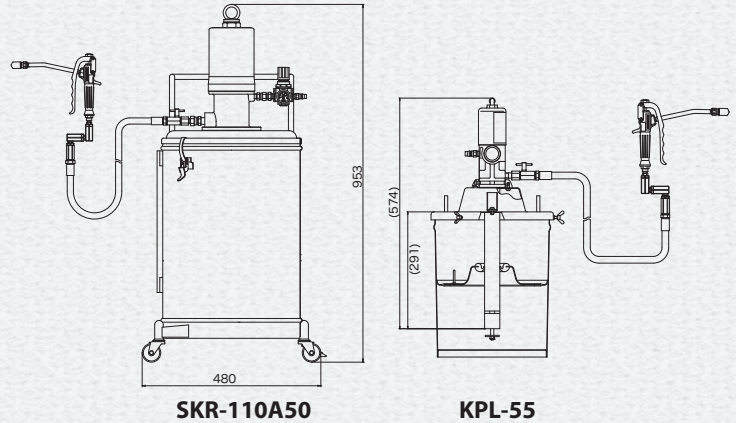

Specifications

| Model No. | Model | Container | Pump Ratio | Max Discharge Pressure (MPa) | Max Discharge Volume (g/min) | Max Air Consumption (g/min) | Weight (kg) | Accessories |
|-----------|------------|-----------|------------|------------------------------|------------------------------|-----------------------------|-------------|--|
| 880870 | SKR-55 | Pail | 55 : 1 | 38.5 | 320 | 212 | 13.5 | 852498 SKR-55PA Grease Transfer Pump.....1 851985 HPG-G HP Grease Gun.....1 695034 SKR-2.5M Grease Hose 2.5M.....1 800766 Check Valve.....1 680743 PS-20PM Air Coupler Plug.....1 |
| 880877 | SKR-66 | Pail | 55 : 1 | 38.5 | 320 | 212 | 17.6 | 852764 SKR-66PA Grease Transfer Pump.....1 851985 HPG-G HP Grease Gun.....1 695034 SKR-2.5M Grease Hose 2.5M.....1 800766 Check Valve.....1 802161 Follower Plate.....1 801241 SKR-AR Air Regulator w/ Air Plug.....1 |
| 880631 | SKR-110A50 | Pail | 50 : 1 | 35.0 | 1200 | 320 | 25.0 | 851779 PD110A50P Grease Transfer Pump.....1 851985 HPG-G HP Grease Gun.....1 695034 SKR-2.5M Grease Hose 2.5M.....1 800431 Check Valve.....1 803481 Follower Plate.....1 802553 AR-110A Air Regulator w/ Air Plug.....1 |
| 880873 | KPL-55 | Pail | 55 : 1 | 38.5 | 320 | 212 | 9.4 | 852765 KPL-55PA Grease Transfer Pump.....1 851985 HPG-G HP Grease Gun.....1 695034 SKR-2.5M Grease Hose 2.5M.....1 800766 Check Valve.....1 802161 Follower Plate.....1 |

Optional Accessories

| Model No. | Model | Description | Fits Model |
|-----------|----------|----------------------------|------------------------------------|
| 802161 | | Follower Plate | SKR-55, SKR-66, KPL-55 |
| 802335 | KPL-55C | Caster | KPL-55 |
| 695062 | SKR-1.5M | Grease Hose 1.5M Max 42MPa | SKR-55, SKR-66, SKR-110A50, KPL-55 |
| 695050 | SKR-2M | Grease Hose 2M Max 42MPa | SKR-55, SKR-66, SKR-110A50, KPL-55 |
| 695034 | SKR-2.5M | Grease Hose 2.5M Max 42MPa | SKR-55, SKR-66, SKR-110A50, KPL-55 |
| 695049 | SKR-3M | Grease Hose 3M Max 42MPa | SKR-55, SKR-66, SKR-110A50, KPL-55 |
| 695098 | SKR-5M | Grease Hose 5M Max 42MPa | SKR-55, SKR-66, SKR-110A50, KPL-55 |
| 695335 | SKR-7M | Grease Hose 7M Max 42MPa | SKR-55, SKR-66, SKR-110A50, KPL-55 |
| 695099 | SKR-10M | Grease Hose 10M Max 42MPa | SKR-55, SKR-66, SKR-110A50, KPL-55 |



802335 KPL-55C



802161 Follower Plate Replacement Hoses

Electric Driven Grease Lubricators

AC100V electric, AC240V electric and DC24V battery driven grease lubricators.
Available with JIS18L/20L pail.



880899 EPL-100 / 881081 EPL-240

880639 KPL-24



Dimensions

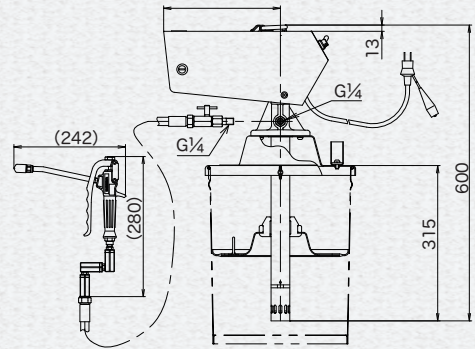

EPL-100 / EPL-240

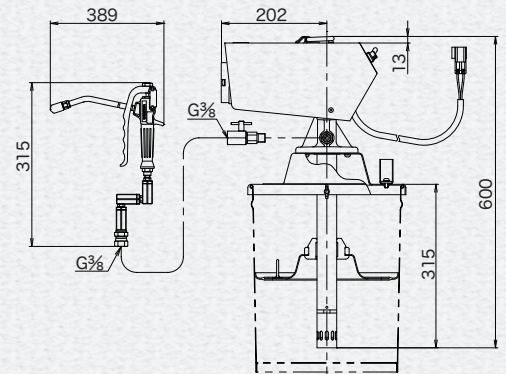

KPL-24

Specifications

| Model No. | Model | Usable Container | Power Source | Discharge Volume (g/min) | Max Discharge Pressure (MPa) | Rotating Speed (rpm) | Quake Resistance | Weight (kg) | Accessories |
|-----------|---------|------------------|-------------------------|--------------------------|------------------------------|----------------------|------------------|-------------|---|
| 880899 | EPL-100 | JIS 18L Pail | AC100V 100W 2.0A | 120-190 | 28 | 90-145 | 4G | 13.0 | 851985 HPG-G HP Grease Gun.....1 |
| 881081 | EPL-240 | | AC240V 100W 0.83A | | | | | | 695034 SKR-2.5M Grease Hose 2.5M.....1 |
| 880639 | KPL-24 | JIS 18L Pail | DC24V 90W 6.3A | 80-120 | 28 (30min,rating) | 95-108 | 4G | 12.0 | 803085 Follower Plate.....1 802493 Power Cord Assy.....1 852164 HPG-G13 HP Grease Gun.....1 685940 Union Adapter.....1 802704 Power Cord Assy.....1 |

Optional Accessories

| Model No. | Model | Description | Fits Model |
|-----------|------------|----------------------------|--------------------------|
| 851003 | S-20 | Dolly | EPL-100, EPL-240, KPL-24 |
| 802335 | KPL-55C | Caster | EPL-100, EPL-240, KPL-24 |
| 695062 | SKR-1.5M | Grease Hose 1.5M Max 42MPa | EPL-100, EPL-240 |
| 695050 | SKR-2M | Grease Hose 2M Max 42MPa | EPL-100, EPL-240 |
| 695034 | SKR-2.5M | Grease Hose 2.5M Max 42MPa | EPL-100, EPL-240 |
| 695049 | SKR-3M | Grease Hose 3M Max 42MPa | EPL-100, EPL-240 |
| 695098 | SKR-5M | Grease Hose 5M Max 42MPa | EPL-100, EPL-240 |
| 695335 | SKR-7M | Grease Hose 7M Max 42MPa | EPL-100, EPL-240 |
| 695099 | SKR-10M | Grease Hose 10M Max 42MPa | EPL-100, EPL-240 |
| 695303 | KPL-24-10M | Grease Hose 10M Max 42MPa | KPL-24 |
| 802817 | KPL-E5M | Extension Power Cord 5M | KPL-24 |
| 683239 | KPL-BK | Cover | KPL-24 |
| N834488 | HR-3C15 | Open Hose Reel 15M | KPL-24 |



N834488 HR-3C15



851003 S-20



Replacement Hoses



802817 KPL-E5M



683239 KPL-BK



802335 KPL-55C

Air-Operated Oil Transfer Pumps

Oil Transfer Drum Pumps

Air-operated oil transfer pumps. Drum Bung Adapter is equipped as a standard.



852628 DR-50A1 852633 DR-50A3 880966 DR-90A3

Dimensions

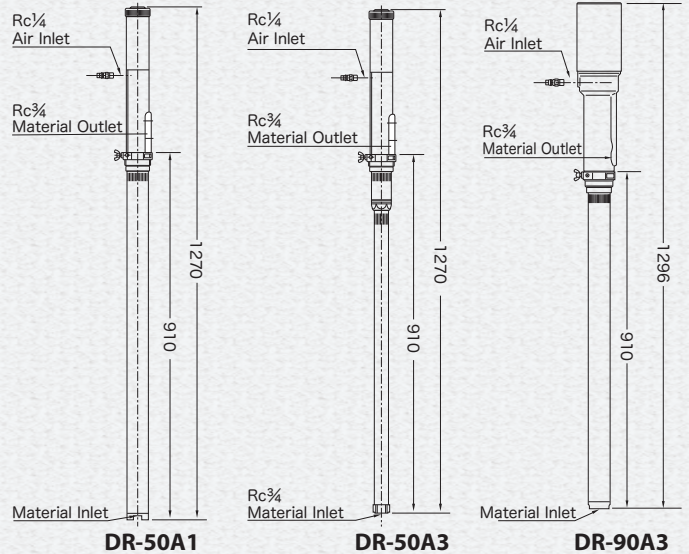

Specifications

| Model No. | Model | Pump Ratio | Max Discharge Volume (g/min) | Max Air Consumption (g/min) | Weight (kg) | Discharge Port |
|-----------|---------|------------|------------------------------|-----------------------------|-------------|----------------|
| 852628 | DR-50A1 | 1 : 1 | 29.0 | 460 | 5.0 | Rc3/4" |
| 852633 | DR-50A3 | 3 : 1 | 12.0 | 470 | 5.4 | |
| 880966 | DR-90A3 | | 22.0 | 550 | 7.1 | |

Oil Transfer Siphon Pumps

Short shank type. Suitable for wall mounting.



852629 SH-50A1 852634 SH-50A3 880967 SH-90A3

Dimensions

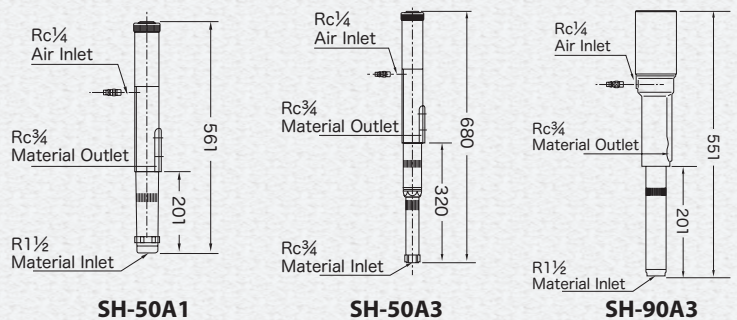

Specifications

| Model No. | Model | Pump Ratio | Max Discharge Volume (g/min) | Max Air Consumption (g/min) | Weight (kg) | Discharge Port |
|-----------|---------|------------|------------------------------|-----------------------------|-------------|----------------|
| 852629 | SH-50A1 | 1 : 1 | 29.0 | 460 | 2.6 | Rc3/4" |
| 852634 | SH-50A3 | 3 : 1 | 12.0 | 470 | 3.3 | |
| 880967 | SH-90A3 | | 22.0 | 550 | 4.5 | |

Pressure Relief Valve & Return Hose

Devices for the purpose of protecting pump, pipe and control valves. When internal pressure of pipe reaches predetermined limit, the Pressure Relief Valve opens and the excess oil is released from the pipe to the drum/tank through the Return Hose.

| Model No. | Model | Description |
|-----------|-------|-----------------------|
| 682428 | PRV-7 | Pressure Relief Valve |
| 695358 | | Return Hose |

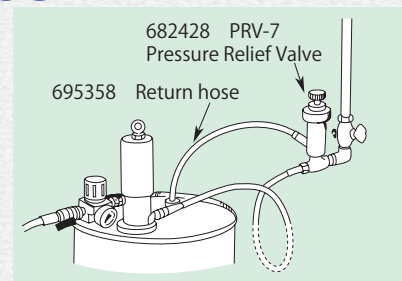

Wall/Floor Mounting Sets

Wall/Floor mounting sets for Oil Transfer Siphon Pumps.

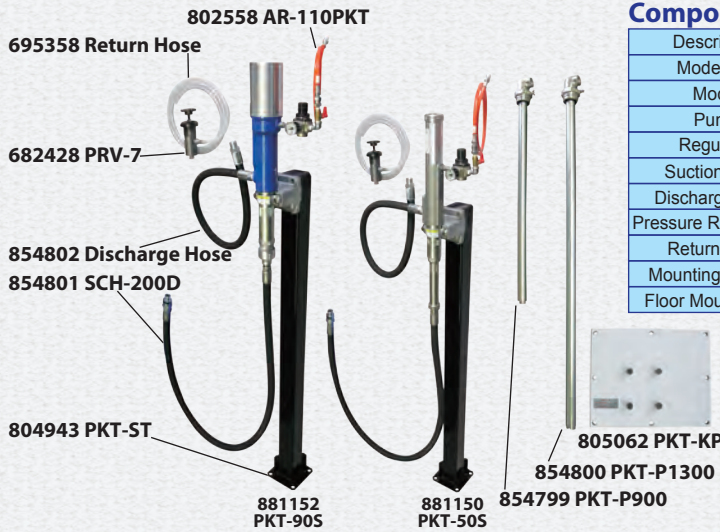

Components

| Description | Wall Mounting Set | | Floor Mounting Set | |
|-----------------------|--|----------------|--------------------|----------------|
| | Model No. | Model | Model No. | Model |
| Model No. | 881149 | 881151 | 881150 | 881152 |
| Model | PKT-50 | PKT-90 | PKT-50S | PKT-90S |
| Pump | 852634 SH-50A3 | 880967 SH-90A3 | 852634 SH-50A3 | 880967 SH-90A3 |
| Regulator | 802558 AR-110PKT (with R1/4 × 1.5m Hose) | | | |
| Suction Hose | 854801 SCH-200D | | | |
| Discharge Hose | 854802 Discharge Hose (R3/4 × 1.5M) | | | |
| Pressure Relief Valve | 682428 PRV-7 | | | |
| Return Hose | 695358 Return Hose | | | |
| Mounting Bracket | 800400 MTB-SH | | | |
| Floor Mount Stand | ----- | | 804943 PKT-ST | |

Optional Accessories

| Model No. | Model | Description | Remark |
|-----------|-----------|----------------------------|-----------------------|
| 854799 | PKT-P900 | Suction Pipe for 200L Drum | L=906mm |
| 854800 | PKT-P1300 | Suction Pipe for Tank | L=1,300mm |
| 805062 | PKT-KP | Wall Mounting Panel | Fits to PKT-50,PKT-90 |

Dolly Sets

Mobile Unit equipped with type 110 air-operated oil pump. *Drum is not included



Components

| Model No. | Model | Pump | Air Regulator | Control Valve | Extension | Swivel Joint | Oil Hose | Dolly | Hose Reel |
|-----------|----------|-----------------|------------------|-----------------|---------------|------------------|----------------|---------------------|-----------------|
| 881083 | LDS-110 | 851754 DR110A5 | 802553 AR-110A | 801428 LBM-G | 801152 NDN-P | 804553 OIL-SJ | 695156 110H-5M | | ----- |
| 881085 | LDS-110R | 851753 SH110A5 | 802558 AR-110PKT | | | | 695866 110H-1M | 802424 LDS-CT | N831989 HR-4G15 |
| 881084 | LDS-110K | Suction Hose | | Suction Pipe | | Mounting Bracket | | Wall Mounting Panel | |
| | | 854801 SCH-200D | 802558 AR-110PKT | 854799 PKT-P900 | 800400 MTB-SH | 805062 PKT-KP | | | |

Liquid Level Alarms

When the liquid level reaches a predetermined limit, this totally pneumatic liquid level sensor automatically stop the pumps and it blows the whistle instead.

It can be mounted to 200L drum directly by 3/4" bung adapter.

When using with Pressure Relief Valve (PRV-7) and Return Hose, please use RL-SA Return Hose Adapter.

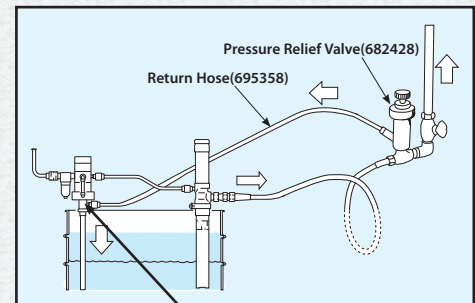
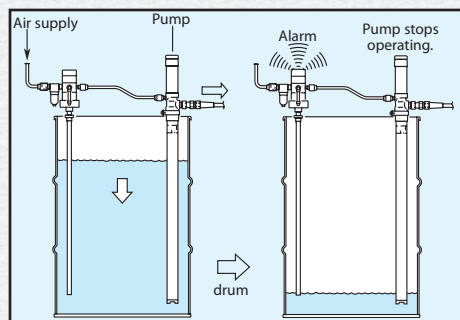

802781 RL-SA
Return Hose Adapter

Specifications

| Model No. | Model | Application | Air Pressure (MPa) | Max Output Air Flow (L/min ANR) | Viscosity Limit | Weight (kg) | Accessories |
|-----------|---------|-----------------------|--------------------|---------------------------------|--------------------|-------------|----------------------------|
| 480007 | SA-4100 | Lower limit detection | 0.25-0.7 | 1000 | 2.5Pa-s (2,500cps) | 2.2 | 680743 PM-20PM Air Coupler |
| 480008 | SA-4110 | Upper limit detection | | | | | |

Air-Operated Grease Transfer Pumps

Grease Transfer Drum Pumps



Air-operated Drum Cover and follower plate kit for 180kg (400lb) and 55kg (120lb) drum.
Grease Gun and wide variety of length of Grease Hoses can be chosen.

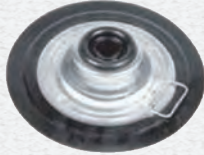

Follower Plates
801977
Follower Plate for 55kg(120lb)
802883
Follower Plate for 180kg(400lb)

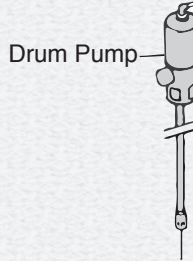

Drum Pump

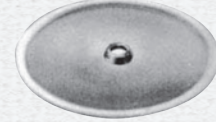

802422 Drum Cover for 55kg (120lb)

704143 Drum Cover for 180kg (400lb)

Dimensions

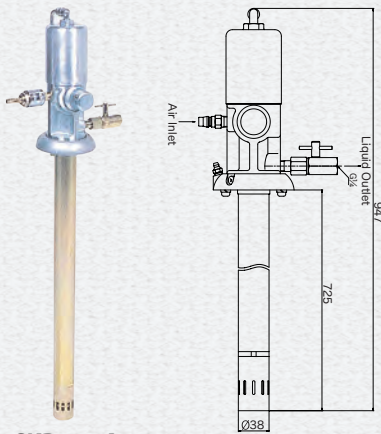

880846 SKR-725A55
Drum Pump for 55kg(120lb) Drum

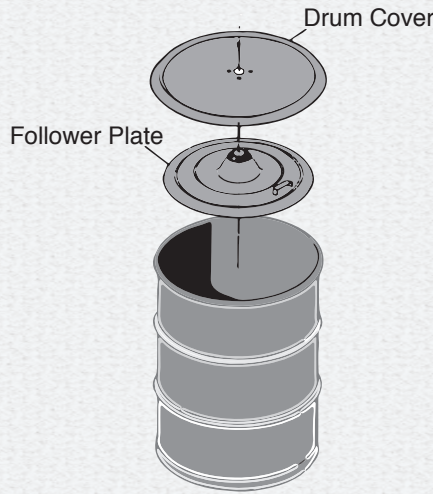

Drum Cover

Follower Plate

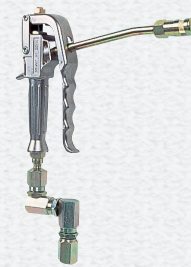

851985 HPG-G
HP Grease Gun

| Model No. | Model | Description | Components |
|-----------|-------|---------------|--|
| 851985 | HPG-G | HP Grease Gun | 852165 Gun Body.....1 800547 CNP-2.....1 802910 HPG-J Swivel-1 |

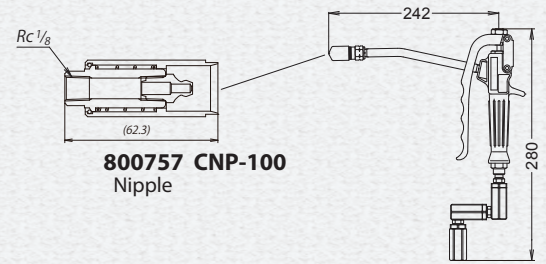

800757 CNP-100
Nipple

851985 HPG-G

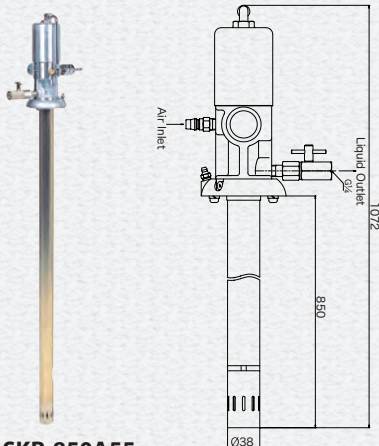

880847 SKR-850A55
Drum Pump for 180kg(400lb) Drum



Grease Hoses

| Model No. | Model | Description |
|-----------|----------|----------------------------|
| 695062 | SKR-1.5M | Grease Hose 1.5M Max 42MPa |
| 695050 | SKR-2M | Grease Hose 2M Max 42MPa |
| 695034 | SKR-2.5M | Grease Hose 2.5M Max 42MPa |
| 695049 | SKR-3M | Grease Hose 3M Max 42MPa |
| 695098 | SKR-5M | Grease Hose 5M Max 42MPa |
| 695335 | SKR-7M | Grease Hose 7M Max 42MPa |
| 695099 | SKR-10M | Grease Hose 10M Max 42MPa |

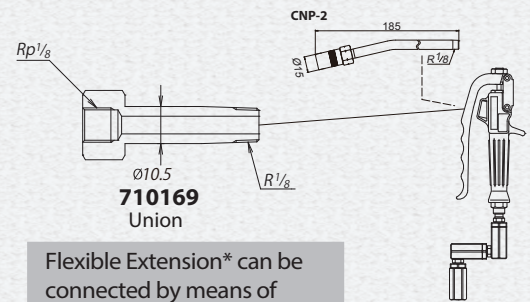

710169
Union

851985 HPG-G

Flexible Extension* can be connected by means of Nipple or Union

*See page 3 for detail

Specifications

| Model No. | Model | Shank Length (mm) | Suitable Container | Pump Ratio | Max Discharge Pressure (MPa) | Max Discharge Volume (g/min) | Max Air Consumption (NL/min) | Weight (kg) | Components |
|-----------|------------|-------------------|--------------------|------------|------------------------------|------------------------------|------------------------------|-------------|--|
| 880846 | SKR-725A55 | 725 | 55kg (120Lbs) | 55:1 | 38.5 | 320 | 212 | 5.8 | 852500 SKR-725P55 Pump.....1 802159 Pump Flange.....1 800766 Check Valve.....1 |
| 880847 | SKR-850A55 | 850 | 180kg (400Lbs) | 55:1 | 38.5 | 320 | 212 | 6.8 | 852501 SKR-850P55 Pump.....1 802159 Pump Flange.....1 800766 Check Valve.....1 |

Compact Reel YR Series

Air Hose Reels

Compact and light-weight air hose reels with durable and flexible 1/4" x 10M hose.



686609
YR-2A10S

686608
YR-2A10

Dimensions

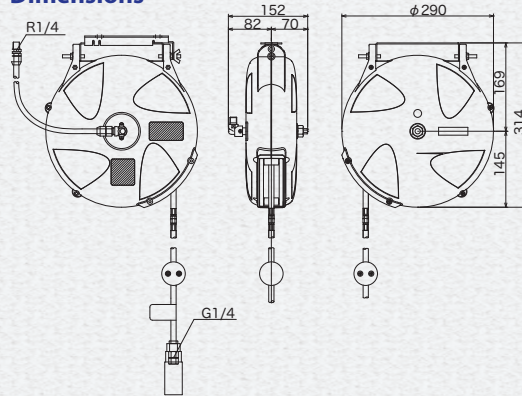

Installation

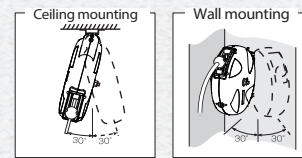

Swing function is equipped as a standard

Easy Coupling

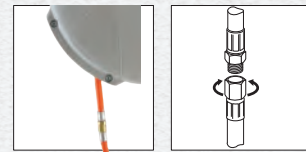

Delivery hose can be changed easily by "Easy Coupling"

Spark Resistant Hose



YR-2A10S is equipped with spark resistant hose

Specifications

| Model No. | Model | Delivery Hose | | | Max Pressure (MPa) | Inlet Hose | | Weight (kg) |
|-----------|----------|---------------|------------|------------|--------------------|------------|------------|-------------|
| | | I.D. (mm) | Length (M) | Connection | | Material | Length (m) | |
| 686608 | YR-2A10 | 6.5 | 10.0 | G1/4" | 1.4 | 0.8 | R1/4" | 3.5 |
| 686609 | YR-2A10S | | | | | | | |

Electric Cord Reels

Compact and light-weight reels for AC100V electric cord.



686610 YR-3E10

Dimensions

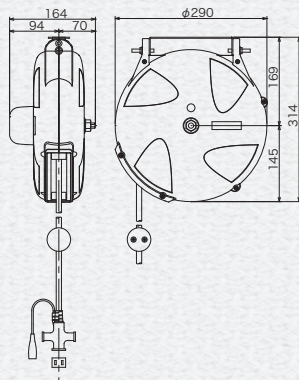

Control Cord Reels

Compact and light-weight reels for remote controller. 4-core, 6-core, 9-core cord are available.



686611 YR-4D08

Dimensions

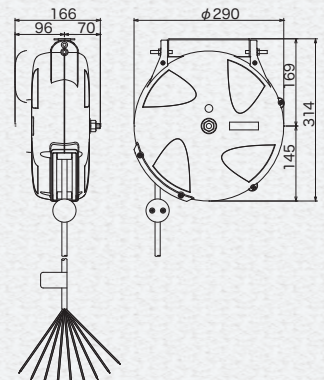

Specifications

| Model No. | Model | Service Cord | | Voltage / Current | Temp Range (°C) | Inlet Cord | | Weight (kg) |
|-----------|---------|---------------------------------------|------------|-------------------|-----------------|------------|---------------|-------------|
| | | Cross Section Area(mm²) x No. of Core | Length (M) | | | Length (M) | Connection | |
| 686610 | YR-3E10 | 1.25 x 3 | 10.0 | AC125V /6A | -5 - 50 | 0.8 | A type socket | 4.1 |

Specifications

| Model No. | Model | Service Cord | | Voltage / Current | Temp Range (°C) | Inlet Cord | | Weight (kg) |
|-----------|---------|---------------------------------------|------------|-------------------|-----------------|------------|------------------------|-------------|
| | | Cross Section Area(mm²) x No. of Core | Length (M) | | | Length (M) | Connection | |
| 686611 | YR-4D08 | 0.75 x 4 | 8.0 | AC/DC24V /0.5A | -5 - 50 | 0.8 | Pin type terminal plug | 3.8 |
| 686612 | YR-6D08 | 0.75 x 6 | | | | | | 3.9 |
| 686613 | YR-9D08 | 0.5 x 9 | | | | | | 4.0 |

Hose Reel HR Series

Hose Reels

Open type hose reel with durable engineering plastic reel drum.

Angle of delivery hose outlet can be adjusted depending of place of installation.



Specifications

| Media | Model No. | Model | I.D. x Length x Connection | | Max Pressure (MPa) | Temp Range (°C) | Weight (kg) | Dimensions (mm) H x W x Ø | Mounting Dimension (mm) |
|--------------|-----------|----------|----------------------------|---------------|-----------------------------------|-----------------|-------------|---------------------------|-------------------------|
| | | | Delivery Hose | Inlet Hose | | | | | |
| Air | 854671 | HR-4A15 | 1/2"x15MxR1/2" | 1/2"x1MxR1/2" | 1.5 | -20 - 60 | 11.2 | 590 x 198 x 476 | 125 x 157 x 4-Ø13 |
| Oil | N834288 | HR-3G10 | 3/8"x10MxG3/8" | 1/2"x1MxG1/2" | 7.5 | -40 - 100 | 12.1 | 560 x 223 x 426 | |
| | N831989 | HR-4G15 | 1/2"x15MxG1/2" | | | | 16.3 | 590 x 238 x 476 | |
| Grease | N834488 | HR-3C15 | 3/8"x15MxG3/8" | 3/8"x1MxG3/8" | 35.0 | | 16.9 | 560 x 228 x 426 | |
| Water | N831889 | HR-4W15 | 1/2"x15MxR1/2" | 1/2"x1MxR1/2" | 1.5 | -30 - 100 | 13.7 | 590 x 198 x 476 | |
| HP Hot Water | N834388 | HR-3WH15 | 3/8"x15MxG3/8" | 3/8"x1MxG3/8" | 25.0MPa (50°C) 10.0MPa (150°C) | -40 - 155 | 13.8 | 560 x 227 x 426 | |

Mounting Brackets

By simply using Mounting Rail and Mounting Bracket, it is possible to install multiple HR series hose reels onto the ceiling easily.

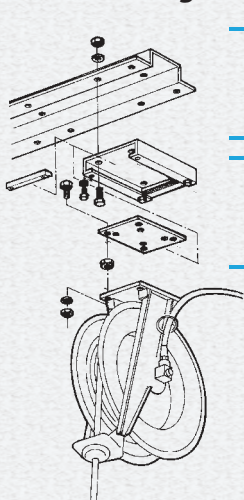

Mounting Rail

| No. of Reel | Model No. | Model | Length (mm) | Weight (mm) |
|-------------|-----------|-------|-------------|-------------|
| 1 | 704439 | R-1 | 140 | 1.5 |
| 2 | 704440 | R-2 | 520 | 5.3 |
| 3 | 704441 | R-3 | 900 | 9.2 |
| 4 | 704442 | R-4 | 1280 | 13.0 |

801951 RK-S Mounting Bracket

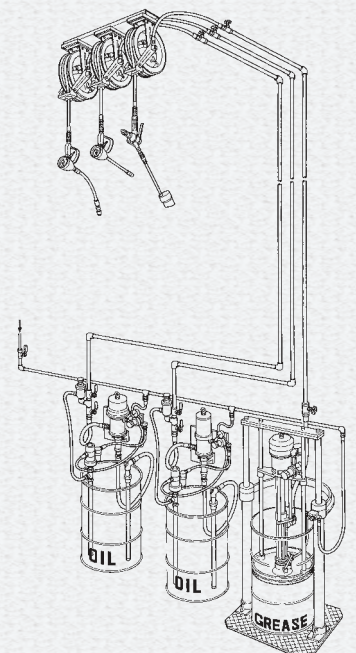

Swing Brackets increase range of use at the wall-mounted.



N372407 RK-W
Wall mounting swing bracket (SPCC)



N372408 RK-WSUS
Wall mounting swing bracket (SUS)

Control Valves

Wide variety of control valves available

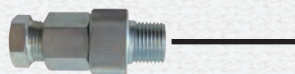

804553 OIL-SJ

Swivel joint
Rc3/8 and Rc1/2 x R1/2



801428 LBM-G

Lube mechanical meter



802765 LBM-D

Digital meter

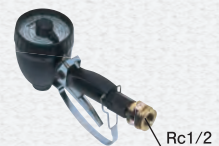

801429 LBM-60

802238 LBM-30
802237 LBM-16
Mechanical preset meter



804569 NDN-FS

Non-drip flexible pipe extension with swivel nozzle



802865 NDN-F

Non-drip flexible pipe extension



801195 NDN-H

Non-drip flexible hose extension



800441 NDN-M

Non-drip steel extension 60° angled head



804570 NDN-PS

Non-drip steel extension with swivel nozzle



801152 NDN-P

Non-drip steel extension



705387 NDZ-P

Steel extension



800440 NDN-G

Non-drip steel extension right-angled head

801204 NDN-L

Non-drip steel extension L-shape pipe



850139 HDV-G

High volume gear oil dispenser



850138 HDV-M

High volume motor oil dispenser



851137 ODV-T

Non-drip oil dispenser T type



851138 ODV-M

Compact size oil dispenser with flow meter



851136 ODV-L

Non-drip oil dispenser L type



800680 DN-L

Non-drip steel extension L type

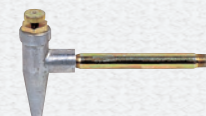

800730 DN-T

Non-drip steel extension T type

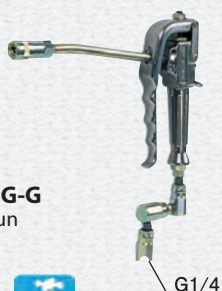

851985 HPG-G

HP Grease Gun



686654 YCL-18LED

AC100V-7W LED pendant light



686653 YCL-18

AC100V-13W fluorescent pendant light



SJ-S Swivel Joint

N431510 1/2x3/8 Brass
N431610 1/2x1/2 Brass
N431710 1/2x3/4 Brass
N431810 1/2x3/8 SUS
N431910 1/2x1/2 SUS
N432010 1/2x3/4 SUS



N400210

SGS-W
Water gun SUS



N400310

SGS-R
High Temperature
Water gun SUS



N400110

SGB-B
Water gun Brass



803926 WG-20

Water spray gun

Dimensions

854671 HR-4A15

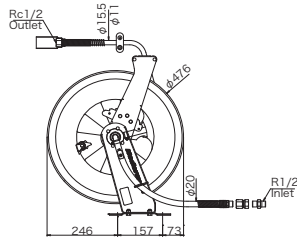

N834488 HR-3C15

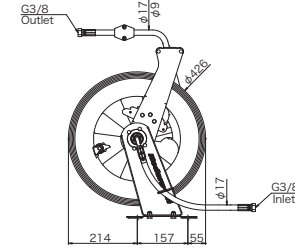

N831889 HR-4W15

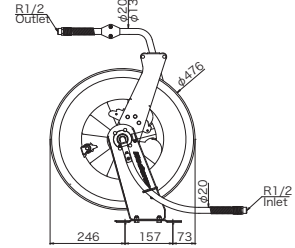

N834388 HR-3WH15

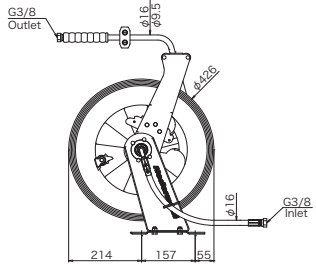

N834288 HR-3G10

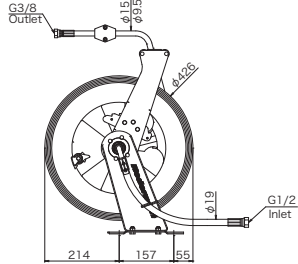

N831989 HR-4G15

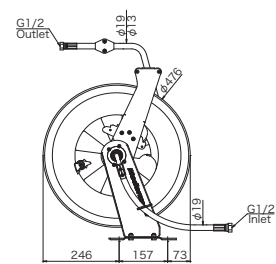

801428 LBM-G, 801237 LBM-16
802238 LBM-30, 801429 LBM-60

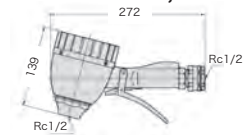

802765 LBM-D

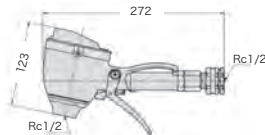

850139 HDV-G

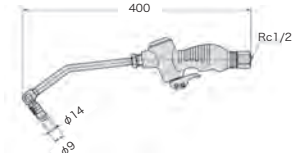

850138 HDV-M

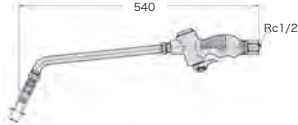

851136 ODV-L

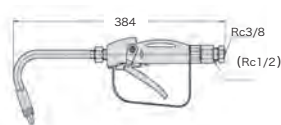

851137 ODV-T

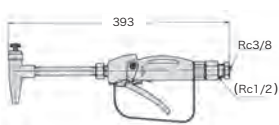

851138 ODV-M

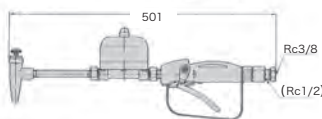

803926 WG-20

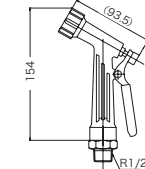

851985 HPG-G

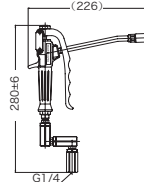

800440 NDN-G

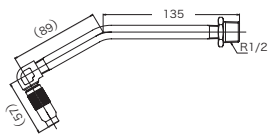

801195 NDN-H

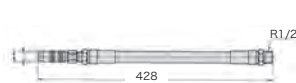

801152 NDN-P



705387 NOZ-P

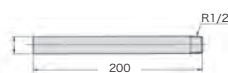

800441 NDN-M

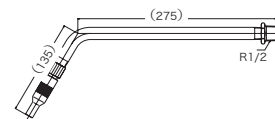

801204 NDN-L

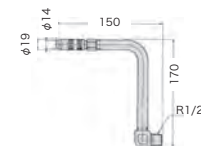

804570 NDN-PS



802865 NDN-F

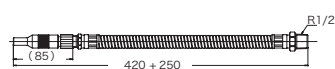

800730 DN-T

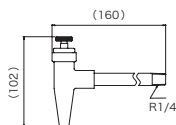

800680 DN-L



804569 NDN-FS

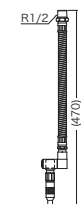

N400110 SGB-B

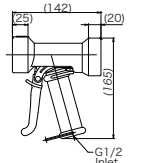

N400210 SGS-W

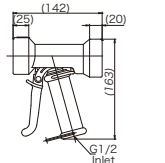

N400310 SGS-R

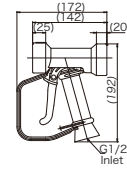

REQUEST SHEET

YAMADA CORPORATION

International Department
Phone:81-(0)3-3777-0241

FAX:81(0)3-3777-0584

For help and recommendations for pump choice and applications, please complete this form with as many details as possible.

Please send it by fax to Yamada Corporation and we will get straight back to you.

- Are you already using Yamada products ? (YES•NO)
- Have you dealt directly with Yamada Corporation in the past ? (YES•NO)
- How did you learn about Yamada Corporation. ()

Purpose of this request.

- Request for technical information.
- Request for quotation.
- Request to purchase products.
- Request for more information.
- Request for catalogues of flyers.
- Request for local dealer contact details.
- Other.

Company _____

Address (with Postcode): _____

Phone:() Fax:()

Department/Section/Group: _____ Name _____

To: YAMADA CORPORATION, International Department

Please provide a sketch of your system including as many details as possible

1) Potential product: Model _____ Diameter _____ A _____

2) Objectives: _____

3) Specifications of fluid:

| | | | |
|---|------------------|----------------|-----------------|
| Name | Fluid properties | Concentration | % |
| Specific gravity | Viscosity | cp | Temperature °C |
| Slurry included? <input type="checkbox"/> Yes / <input type="checkbox"/> No | | →Concentration | Wt% Diameter mm |

4) Pump output (Flow rate) Nominal rate _____ /min _____ /hr Max. rate _____ /min _____ /h

Total stroke _____ M MPa

Ambient temperature _____

5) Fluid container: 200L Drum container 20L Pail container 18L square container

Custom container: Specifications _____

6) Operation conditions: Outdoor / Indoor

Operation frequency (How often do you run your pump?) Continuous / Intermittent hr/day or hr/week or hr/month

7) Air supply condition: _____ MPa

8) Number of units: _____ unit(s)

9) Expected commercial conditions _____

10) Other requirements _____



CAUTION WHEN SELECTING A PUMP

Yamada offers a large range of Lubrication Equipment to cater for many different kinds of materials and conditions. When selecting the most appropriate pump for a particular selection and installation please consult your local Yamada Pump Distributor or Yamada Corporation.

Your Local Distributor:

YAMADA CORPORATION
International Department
No.1-3, 1-Chome, Minami-Magome,
Ohta-ku,Tokyo 143-8504, Japan

Phone +81-(0)3-3777-0241
Fax +81-(0)3-3777-0584

E-mail: intl@yamadacorp.co.jp
Web: www.yamadacorp.co.jp/global

All product specifications and data are subject to change without notice.
Form no.:910-416E Revised: Mar. 2016