

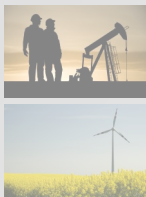

The Ultimate Innovators

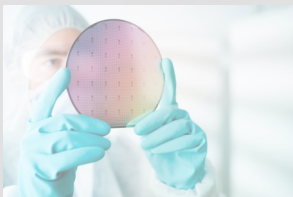



Yamada Corporation

Since its beginning in 1905, Yamada® has been at the forefront in developing the most complete line of air operated double diaphragm pumps on the planet. Unmatched in quality, durability and availability, there's no question as to why more and more industries are coming to Yamada for their pumping needs. As an ISO 9001 certified company, our engineering intellect and manufacturing processes are second to none. Yamada remains dedicated to the continuous development of the most complete line of air operated diaphragm pumps available today. Our philosophy is quite simple. We offer the best product and support it with the best service. This is all backed by the lowest cost of ownership in the industry. We welcome the opportunity to earn your business.

The Proof's in the Pump.

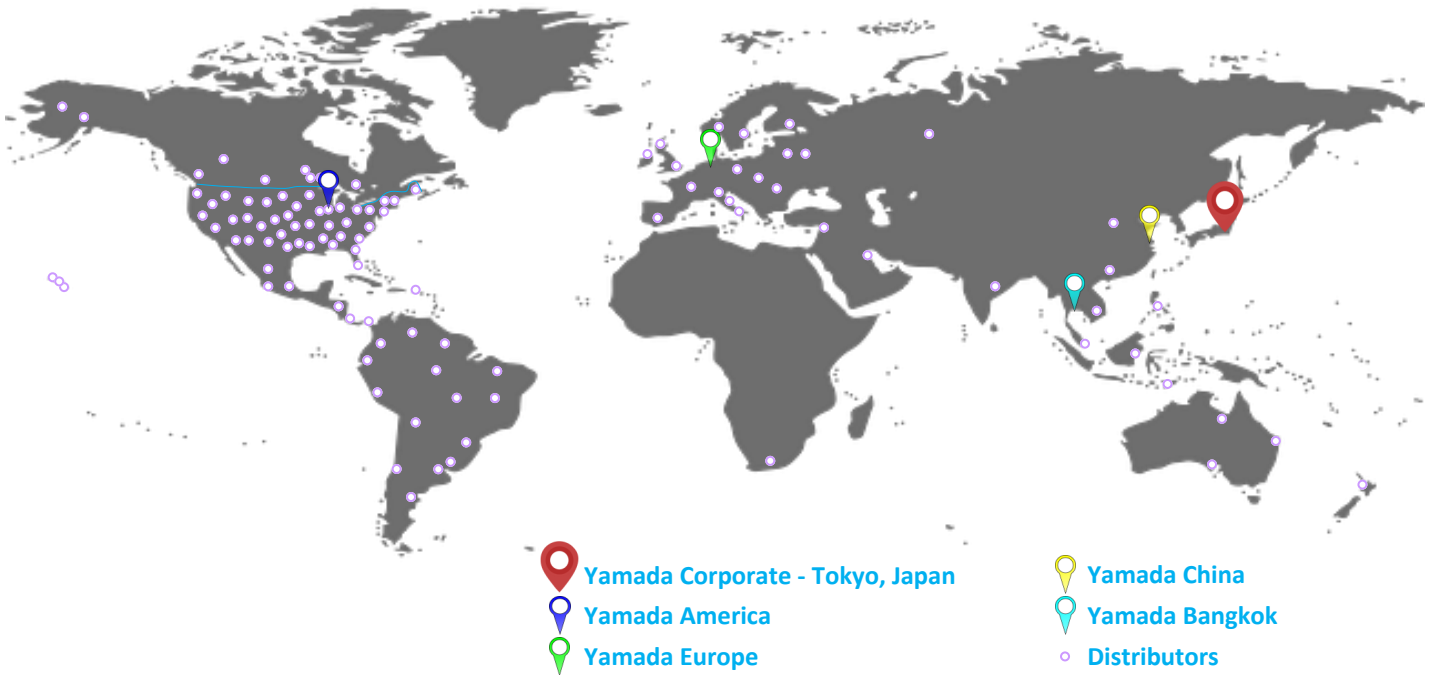

Yamada America

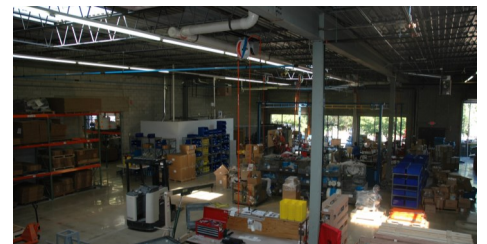

APPLICATIONS & MAJOR MARKETS SERVED

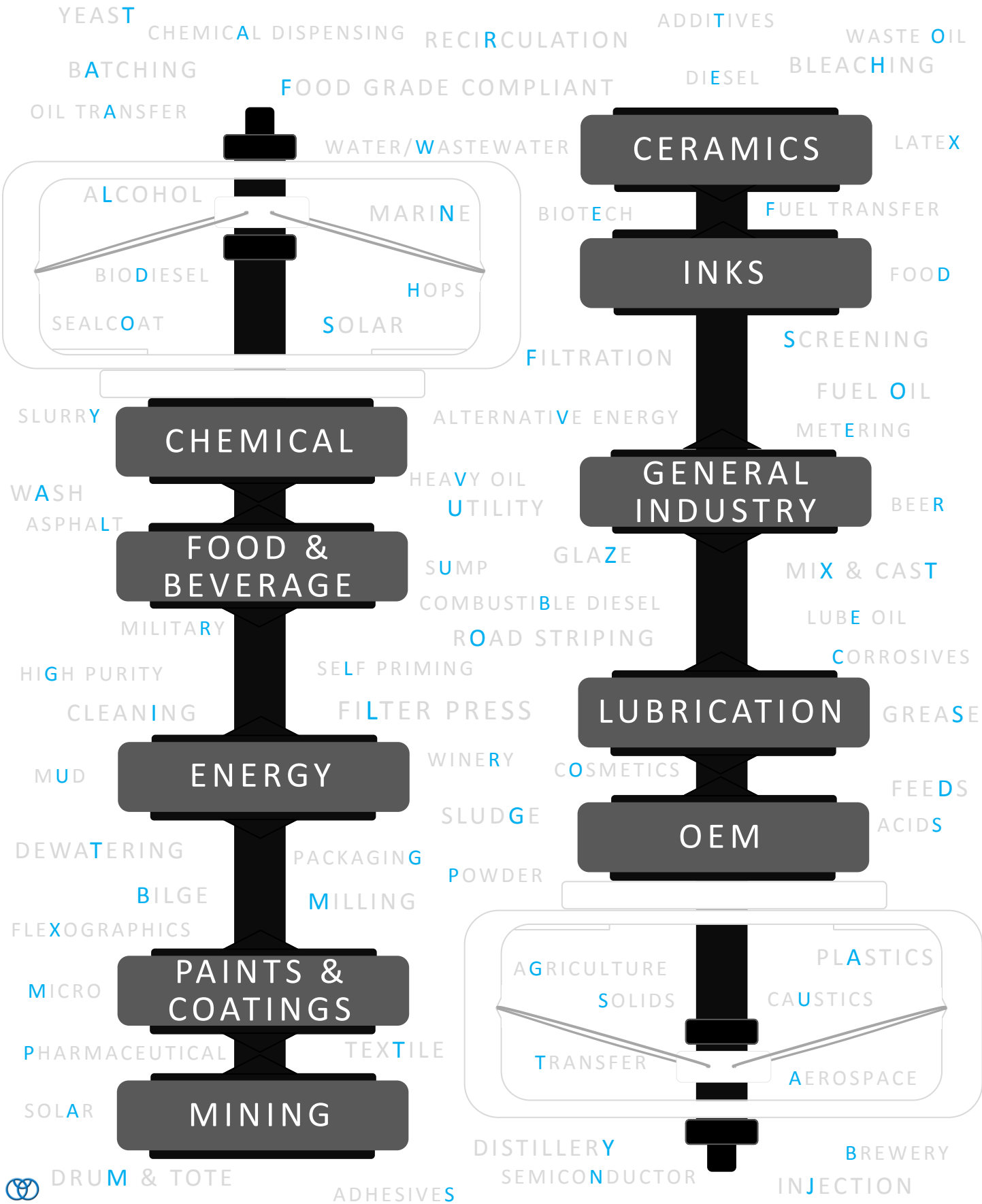

Rugged, Bolted Construction

- Leak Free / Registered Fit

Manifold Design

- Optimal Flow

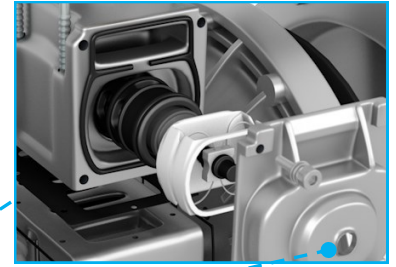

Manual Override

Air Valve

- Outside Accessible / Easy Inspection
- Longest service life in the industry
- Modular-component replaceable / Repair friendly
- Non-Lube (never requires lube or grease) / No intermittent maintenance
- Non-Stalling (C-Spring assures positive shift)

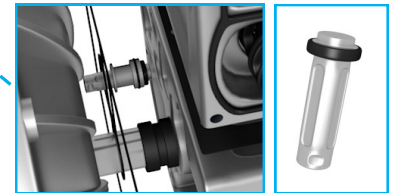

Pilot Valve

- No Dynamic O-rings / No Lube / Maintenance Free
- No snap rings or lubricated O-rings to replace or repair.
- Will not bend under load

Strong Bases-Steel Construction

- Powerful base absorbs shock without damage to pump

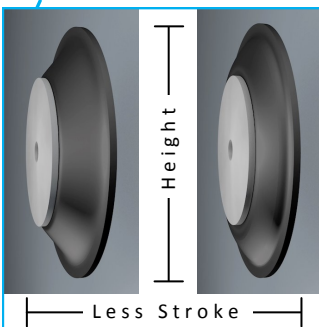

Diaphragm Dynamics

- Optimal stroke length to maximize diaphragm life without sacrificing performance

- Many Porting Options Available



Sizes & Materials

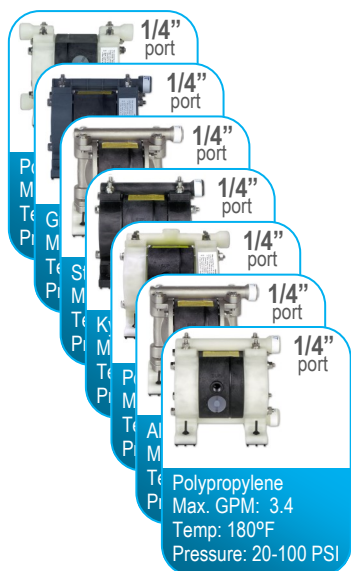

NDP-5 Series

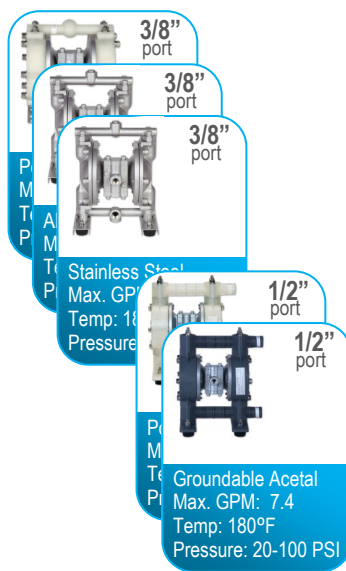

DP-10 / 15 Series

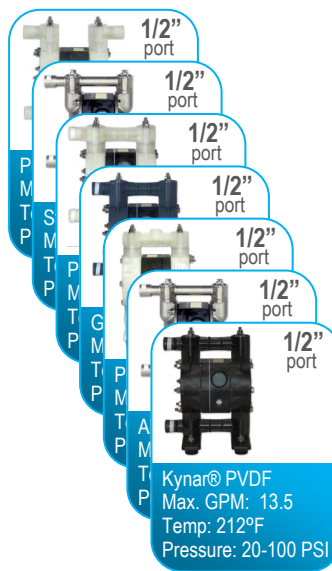

NDP-15 Series

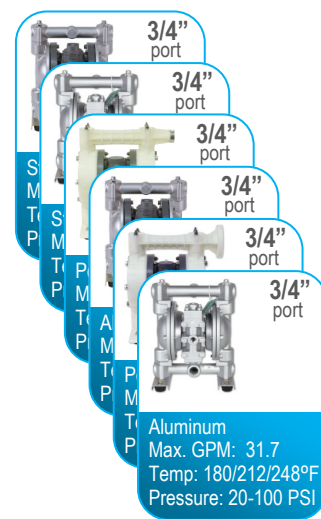

NDP-20 Series

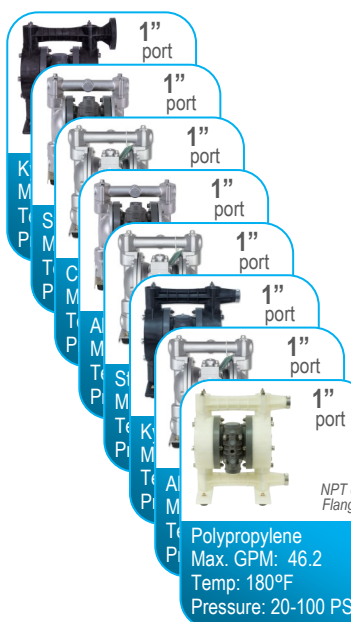

NDP-25 Series

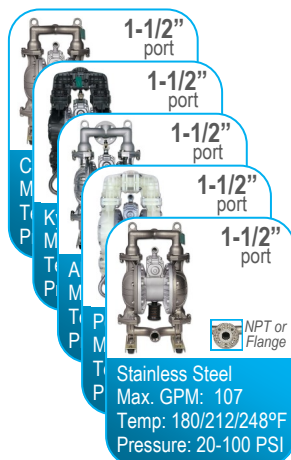

NDP-40 Series

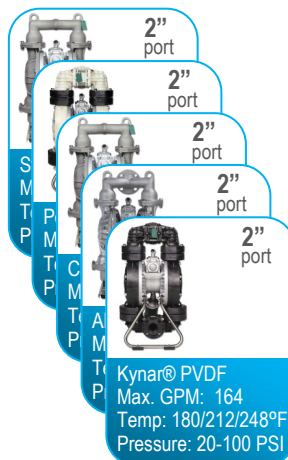

NDP-50 Series

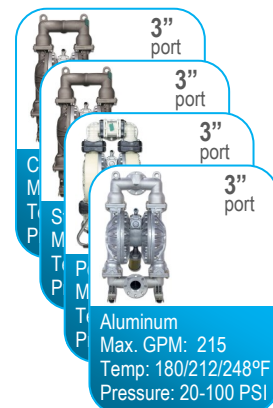

NDP-80 Series

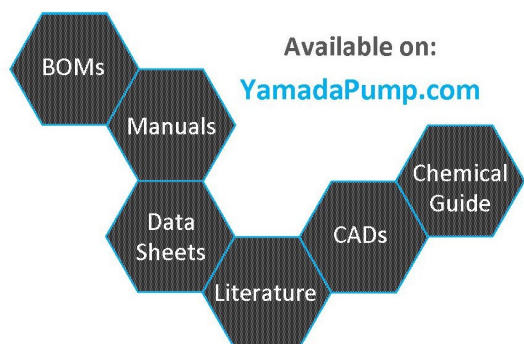

Materials of Construction:

Polypropylene
Kynar®
Acetal
Aluminum
Stainless Steel
Cast Iron

Diaphragm Material:

Buna N (NBR)
Neoprene (CR)
Santoprene®
Nordel™ (EPDM)
PTFE
Hytrell® (TPE)
Viton®

Port Size:

1/4"
3/8"
1/2"
3/4"
1"
1-1/2"
2"
3"

Specialty Pumps

2:1 HIGH PRESSURE PUMPS

FDA COMPLIANT PUMPS

SOLIDS HANDLING

DRUM PUMPS

UL-79 PUMPS

POWDER PUMPS

SPLIT MANIFOLD PUMPS

CSA CERTIFIED NATURAL GAS

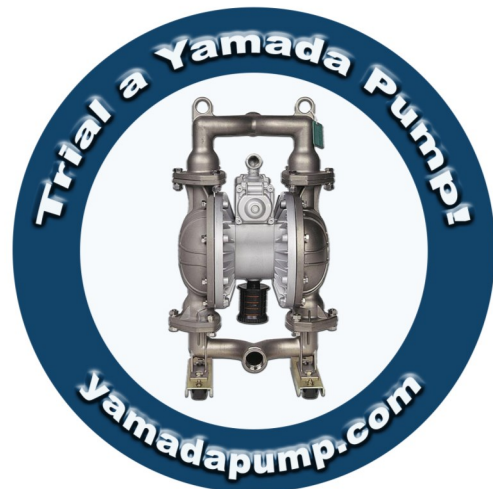
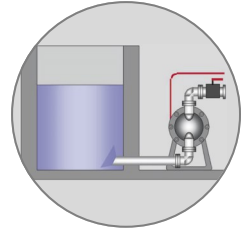
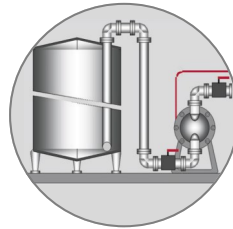
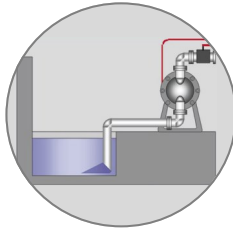
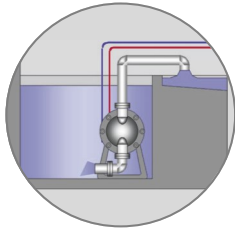
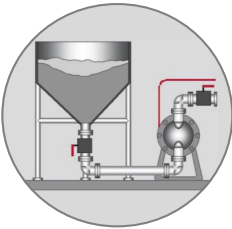

The Proof's in the Pump.

Whether your pumps are functioning continuously or intermittently, operate with high or low pressure, or see dirty, wet air, Yamada offers one field proven design.

Go to www.yamadapump.com or call (800) 997-7867 to register for your free trial pump.



Copyright 2016 Yamada® America, Inc. All rights reserved.
Designed and printed in the U.S.A. Form#: PO0216



Yamada® is a registered trademark of Yamada American, Inc. Hytel® is a registered trademark of E.I. du Pont de Nemours and Company. Kynar® is a registered trademark of Arkema. Nortel™ is a trademark of DuPont Dow Elastomers. Santoprene® is a registered trademark of Monsanto Co. Viton® is a registered trademark of DuPont Performance Elastomers.