

Industrial Peristaltic Pumps

FMP-60B Model

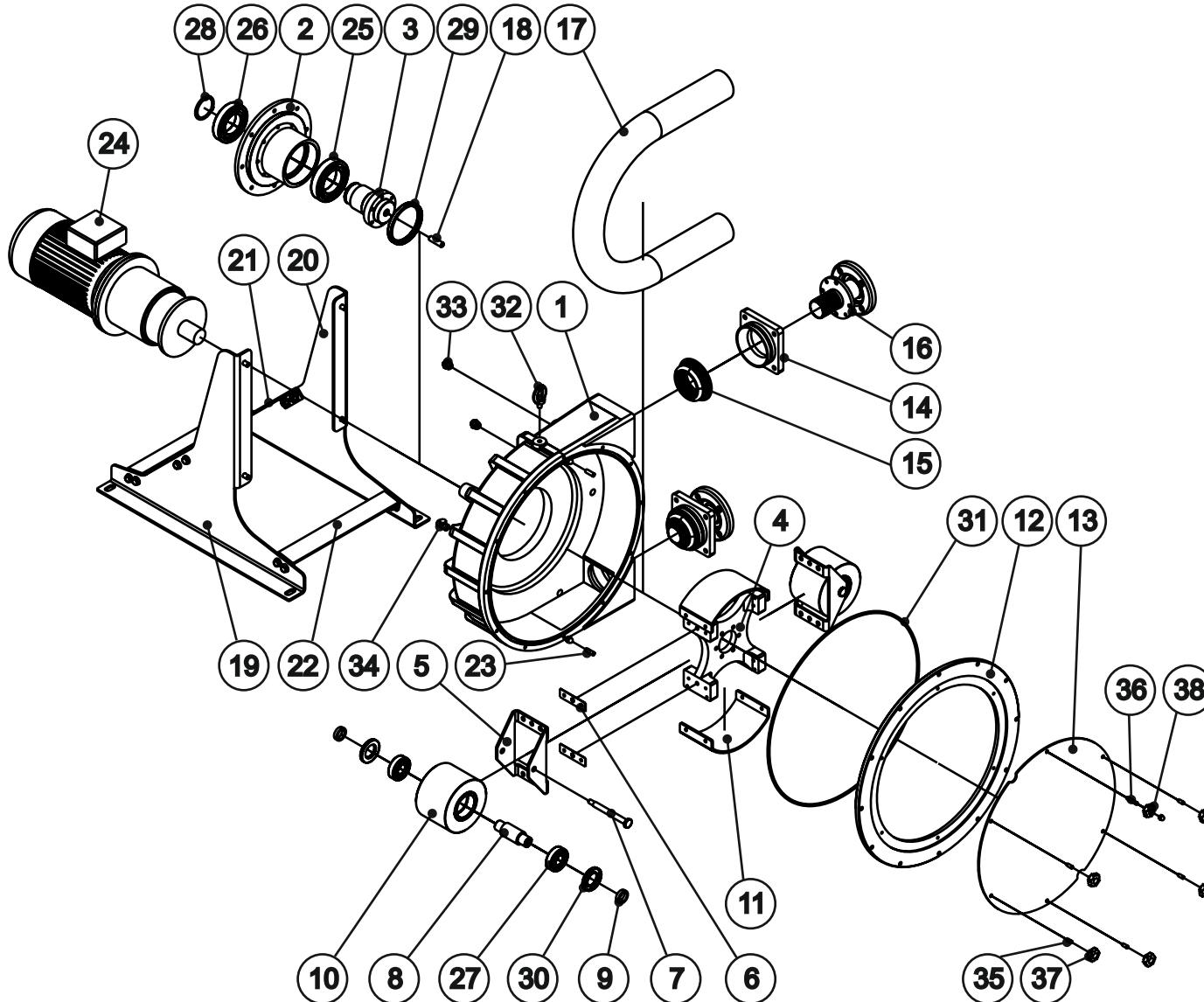

ITEM	DESCRIPTION	Q	CODE
1	Pump casing	1	110.01.01
2	Ball bearing box	1	110.00.03
3	Rotor shaft	1	110.00.04
4	Rotor	1	110.01.05
5	Roller support	2	110.01.06
6	Shim 1mm		110.00.07
	Shim 7mm		110.00.55
	Shim 5mm		110.00.56
7	Shaft screw	2	110.00.08
8	Roller shaft	2	110.00.09
9	Spacer	4	110.00.10
10	Roller	2	110.01.11
11	Lateral rotor	2	110.01.12
12	Front cover metallic	1	110.00.13
13	Front cover polycarbonate	1	110.00.14
14	Press flange	2	110.01.15
15	Press ring	2	110.01.16
16	Connection DN-50 Stainless Steel DIN flange	2	110.01.17
	Connection 2" Stainless Steel ANSI flange	2	110.01.41
	Connection DN-50 Stainless steel DIN 11851	2	110.01.43
	Connection DN-50 Polypropylene DIN flange	2	110.01.64
	Connection 2" polypropylene ANSI flange	2	110.01.63
	Connection DN-50 PVDF / PTFE DIN flange	2	110.01.72
	Connection 2" PVDF / PTFE ANSI flange	2	110.01.65
	Connection 2" Stainless Steel TRI-CLAMP	2	110.01.42
17	Hose NR	1	110.00.18
	Hose NR-A	1	110.00.19
	Hose NBR	1	110.00.20
	Hose NBR-A	1	110.00.21
	Hose EPDM	1	110.00.22
	Hose HYPALON	1	110.00.54
18	Bearing box cap	1	110.00.23
19	Base left	1	110.00.37
	Base left S.S.	1	110.00.48
20	Base right	1	110.00.38
	Base right S.S.	1	110.00.49
21	Middle 100mm	1	110.00.39
	Middle 100mm S.S.	1	110.00.50
22	Middle 60mm	2	110.00.40
23	Middle 60mm S.S.	2	110.00.51
24	Stud (Pump casing)	2	106.00.27
25	Driver	1	
26	box anterior ball bearing	1	110.00.26
27	box posterior ball bearing	1	110.00.27
28	Roller ball bearing	4	110.00.28
29	Seeger ring	1	110.00.29
30	Lip seal (bearing box)	1	110.00.30
31	Lip seal (Roller)	1	110.00.31
32	O-ring cover	1	110.00.33
33	Eye bolt	1	110.00.34
34	Drain plug FMP	3	107.00.41
35	Check valve	1	110.00.53
36	Short stud (front cover)	5	107.00.46
37	Long stud (front cover)	1	107.00.47
38	Press pommel blind	5	102.00.26
39	Press pommel	1	102.00.25