

## Industrial Peristaltic Pumps AMP-16D Data sheet

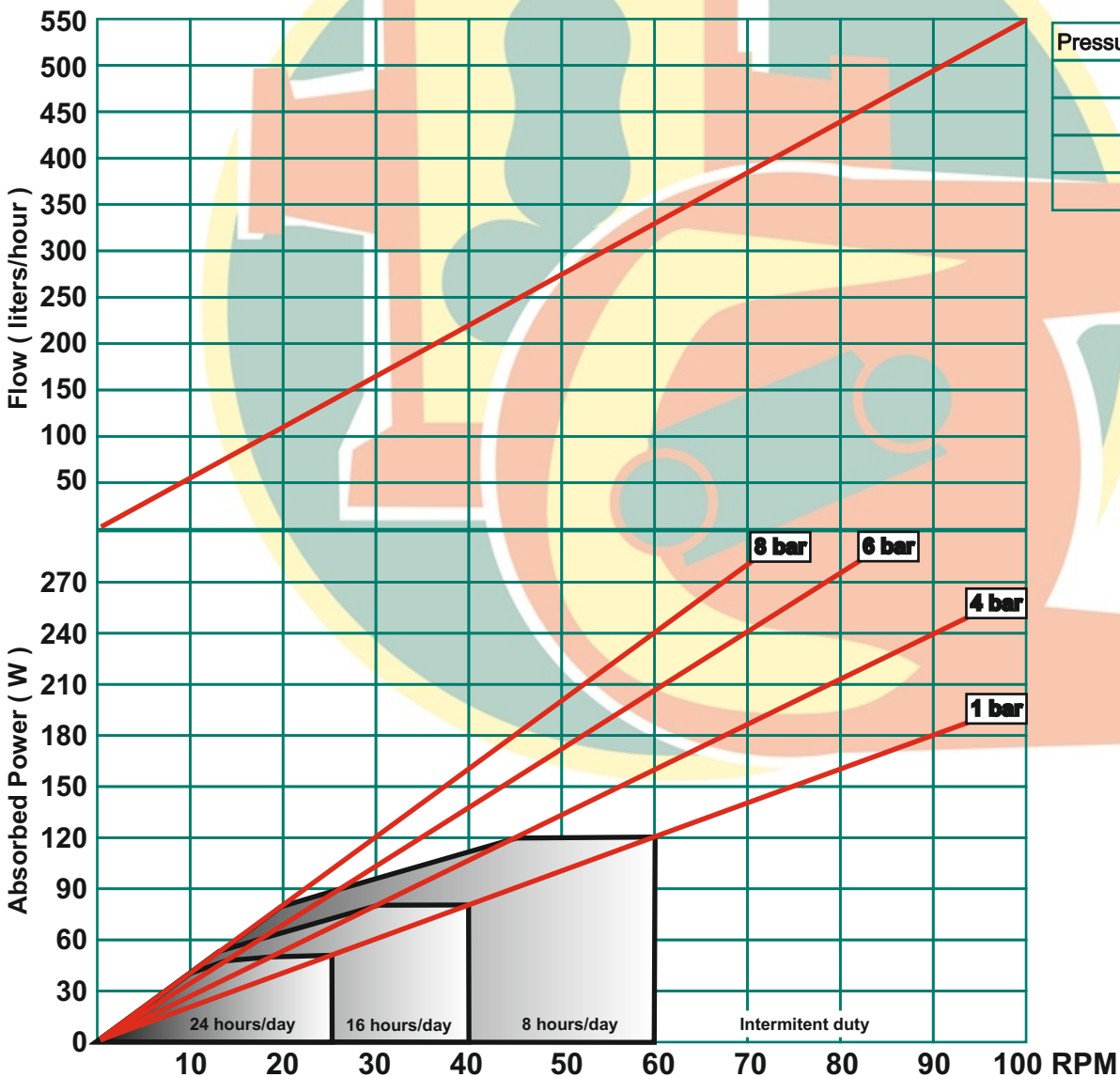

**Capacity:** 0,092 l/rev.  
**Connections:** 3/4"  
**Max. Pressure:** 8 bar  
**Rotor system:** Rollers  
**Available hoses:** NR  
 NBR  
 EPDM  
 HYPALON  
 NR-A  
 NBR-A  
**Available tubes:** Norprene



Pressure (bar)	Torque (Nm)
1	20
4	26
6	33
8	38



Description	Material	Surface treatment
Pump housing	Aluminium EN-AC-44100	Polyester powder coated Halar coated ( Optional )
Front cover	Steel F-111 / Polycarbonate	Polyester powder coated Halar coated ( Optional )
Rotor	Nodular Cast Iron EN-GJL-400	Cataforesis
Rollers	Steel F-114	Blueing
Base plate	Steel F-111 Stainless Steel AISI-304 ( Optional )	Polyester powder coated --
Connections	Stainless Steel AISI-316 Polypropylene ( Optional ) PVDF ( Optional )	--

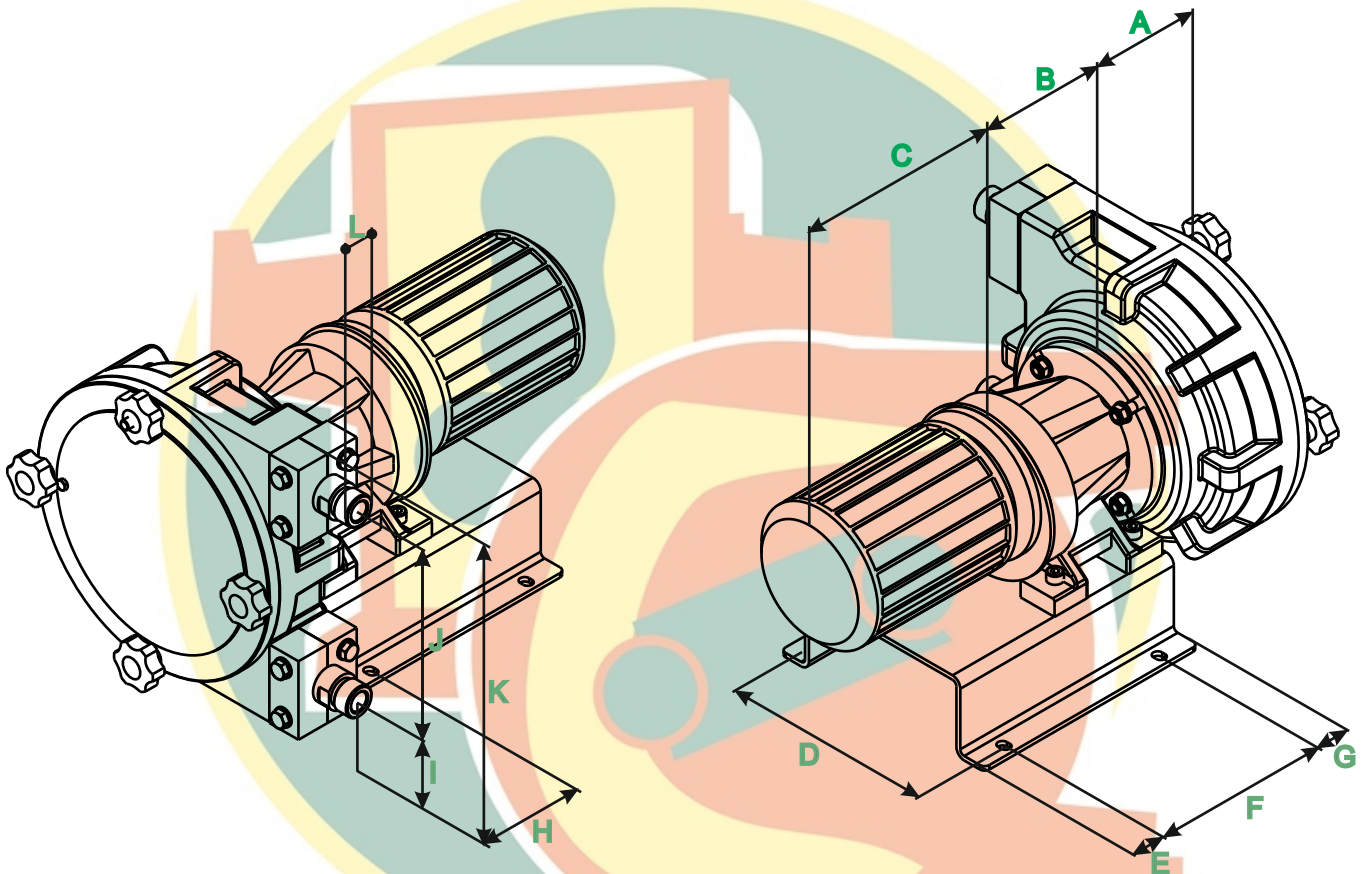

A	B	C	D	E	F	G	H	I	J	K	L
119	*	*	190	30	160	30	75	60	170	265	3/4" BSP

\* To confirm according type and power driver.



Bombas Boyser, S.L. C/ Narcís Monturiol, 24 · Pol. Ind. Can Magre  
Telf.: 93 844 77 78 · 08187 Sta. Eulàlia de Ronçana (BARCELONA)  
[info@boyser.com](mailto:info@boyser.com) · [www.boyser.com](http://www.boyser.com)

