

HN (HQ) - A-Motor

Heavy Duty (Gehäusenendruck / Casing Pressure 40bar)

NIKKISO

NIKKISO PUMPS EUROPE

Nikkisostrasse • D-63674 Albstadt/Hessen

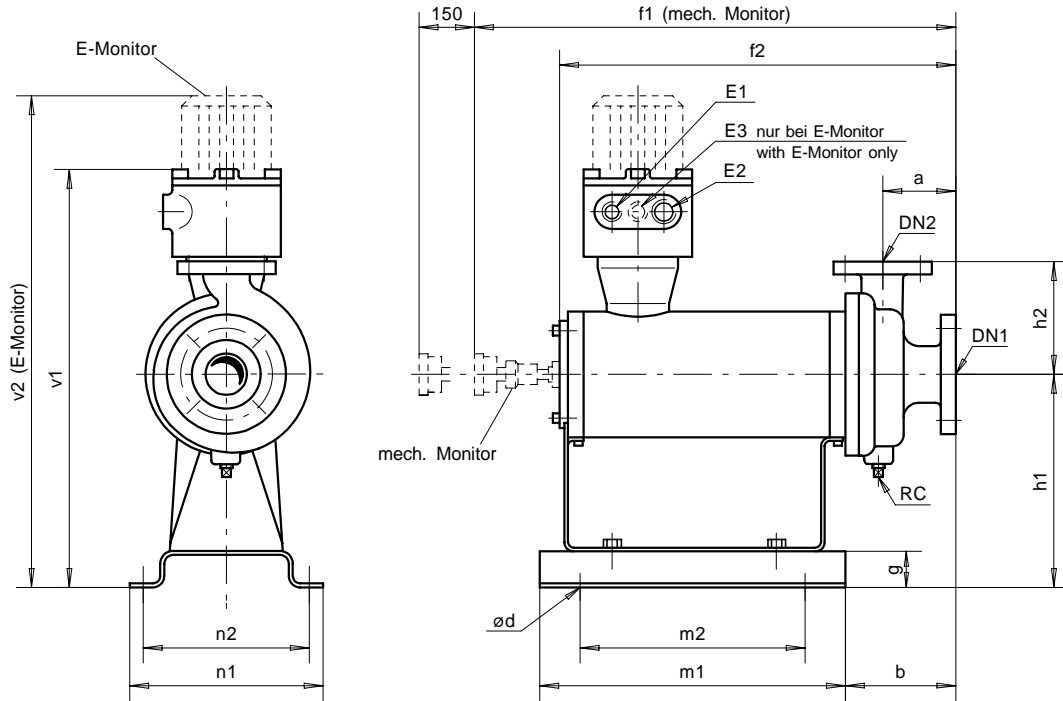

Maße / Dimensions in [mm]
Gewichte / Weights in [kg]

Modell	DIN PN40 DN1	ANSI #300 DN2	RC	a	b	ød	f1	f2	g	h1	h2	m1	m2	n1	n2	v1	v2	E1	E2	E3	Gew. Wt.
HN21A-A1							530	413				256	156								55
HN21A-A2	50	32	2"	1 1/2"	1/2"	80	564	447	40	240	160	290	190	210	185	510	623	M20	M32	M20	60
HN21A-A3							592	475				318	218								60
HN21B-A1							529	412				256	156								55
HN21B-A2	50	32	2"	1 1/2"	1/2"	80	563	446	40	240	160	290	190	210	185	510	623	M20	M32	M20	60
HN21B-A3							591	474				318	218								60
HN21C-A1							530	413				256	156								55
HN21C-A2	50	32	2"	1 1/2"	1/2"	80	564	447	40	240	160	290	190	210	185	510	623	M20	M32	M20	60
HN21C-A3							592	475				318	218								65
HN22A-A1							539	422				256	156								55
HN22A-A2	50	32	2"	1 1/2"	1/2"	80	573	456	40	240	160	290	190	210	185	510	623	M20	M32	M20	60
HN22A-A3							601	484				318	218								60
HN22B-A1							536	419				256	156								60
HN22B-A2	50	32	2"	1 1/2"	1/2"	80	570	453	40	240	160	290	190	210	185	510	623	M20	M32	M20	60
HN22B-A3							598	481				318	218								65
HN22C-A1							551	434				256	156								60
HN22C-A2	50	32	2"	1 1/2"	1/2"	100	585	468	40	240	180	290	190	210	185	510	623	M20	M32	M20	65
HN22C-A3							613	496				318	218								70
HN22D-A1							560	443				256	156								65
HN22D-A2	50	32	2"	1 1/2"	1/2"	100	594	477	40	240	180	290	190	210	185	510	623	M20	M32	M20	70
HN22D-A3							622	505				318	218								75
HN23A-A1							569	452				256	156								60
HN23A-A2	65	50	2 1/2"	2"	1/2"	100	603	486	40	240	160	290	190	210	185	510	623	M20	M32	M20	60
HN23A-A3							631	514				318	218								65
HN23B-A1							568	451				256	156								65
HN23B-A2	65	50	2 1/2"	2"	1/2"	100	602	485	40	240	180	290	190	210	185	510	623	M20	M32	M20	70
HN23B-A3							630	513				318	218								70
HN23C-A1							562	445				256	156								70
HN23C-A2	65	50	2 1/2"	2"	1/2"	100	596	479	40	240	200	290	190	210	185	510	623	M20	M32	M20	70
HN23C-A3							624	507				318	218								75
HN24A-A1							583	466				256	156								70
HN24A-A2	80	65	3"	2 1/2"	1/2"	100	617	500	40	240	180	290	190	210	185	510	623	M20	M32	M20	70
HN24A-A3							645	528				318	218								75
HN24B-A1							580	463				256	156								70
HN24B-A2	80	65	3"	2 1/2"	1/2"	100	614	497	40	240	180	290	190	210	185	510	623	M20	M32	M20	75
HN24B-A3							642	525				318	218								80

Technische Änderungen bleiben vorbehalten / Subject to technical alterations