

HN (HQ) - D-Motor

Heavy Duty (Gehäusenendruck / Casing Pressure 40bar)

NIKKISO

NIKKISO PUMPS EUROPE

Nikkisostrasse • D-63674 Albstadt/Hessen

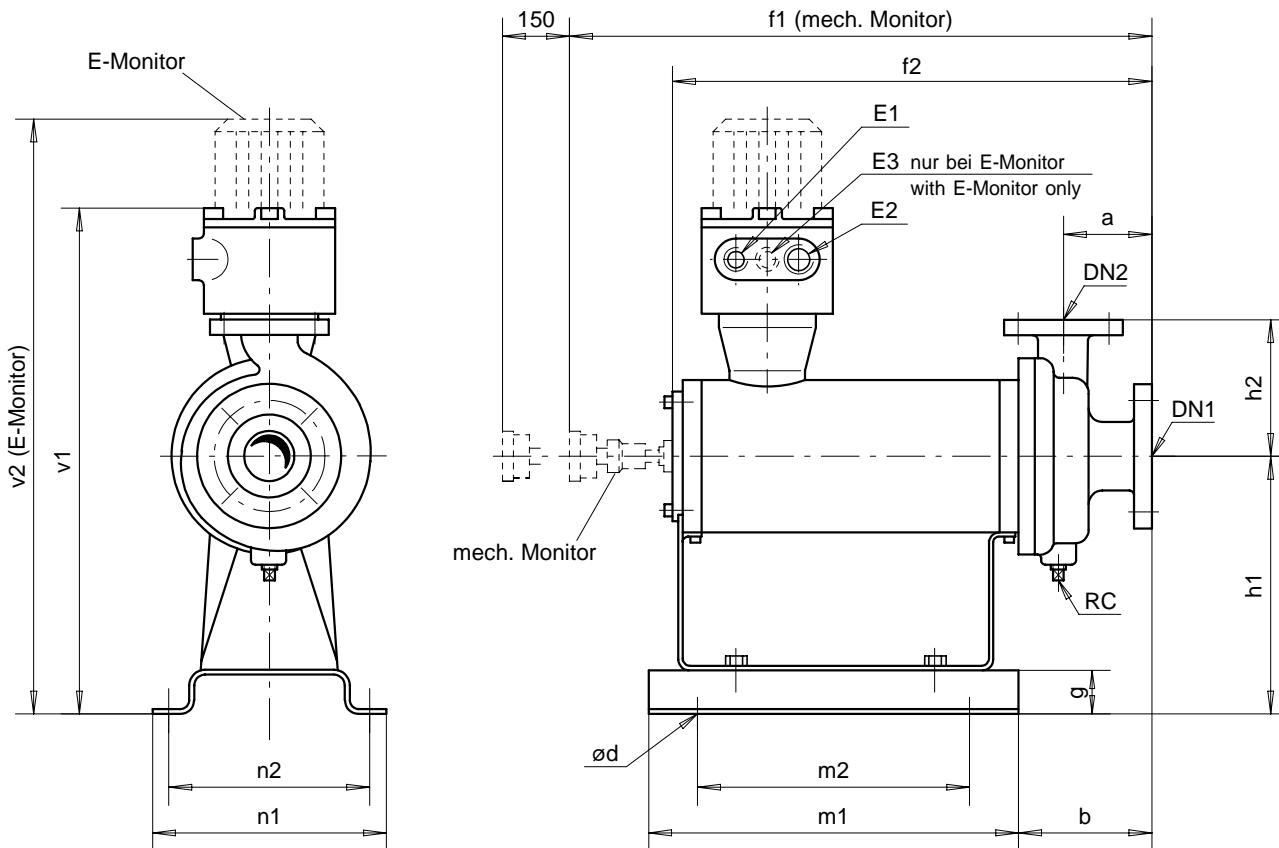

* max. 30bar

Maße / Dimensions in [mm]
Gewichte / Weights in [kg]

Modell	DIN DN1	PN40 DN2	ANSI #300 DN1	ANSI #300 DN2	RC	a	b	ød	f1	f2	g	h1	h2	m1	m2	n1	n2	v1	v2	E1	E2	E3	Gew. Wt.
HN23F-D1	65	40	2 ½"	1 ½"	½"	125	198	19	942	825	60	350	280	630	530	340	300	735	864	M20	M50	M20	275
HN23F-D2									972	855				660	560								290
HN24E-D1 *	80	50	3"	2"	½"	125	214	19	958	841	60	350	280	630	530	340	300	735	864	M20	M50	M20	255
HN24E-D2 *									988	871				660	560								270
HN25C-D1	100	80	4"	3"	½"	125	218	19	962	845	60	350	250	630	530	340	300	735	864	M20	M50	M20	235
HN25C-D2									992	875				660	560								250
HN25D-D1	100	65	4"	2 ½"	½"	125	218	19	962	845	60	350	250	630	530	340	300	735	864	M20	M50	M20	245
HN25D-D2									992	875				660	560								260
HN25E-D1	100	65	4"	2 ½"	½"	125	220	19	964	847	60	350	315	630	530	340	300	735	864	M20	M50	M20	285
HN25E-D2									994	877				660	560								295
HN26C-D1	125	100	5"	4"	½"	165	285	19	1029	912	60	350	330	630	530	340	300	735	864	M20	M50	M20	265
HN26C-D2									1059	942				660	560								275
HN26D-D1	125	100	5"	4"	½"	170	290	19	1034	917	60	350	350	630	530	340	300	735	864	M20	M50	M20	270
HN26D-D2									1064	947				660	560								280

Technische Änderungen bleiben vorbehalten / Subject to technical alterations