

HT (HS) - D-Motor

Heavy Duty (Gehäusenendruck / Casing Pressure 40bar)

NIKKISO

NIKKISO PUMPS EUROPE

Nikkisostrasse • D-63674 Albstadt/Hessen

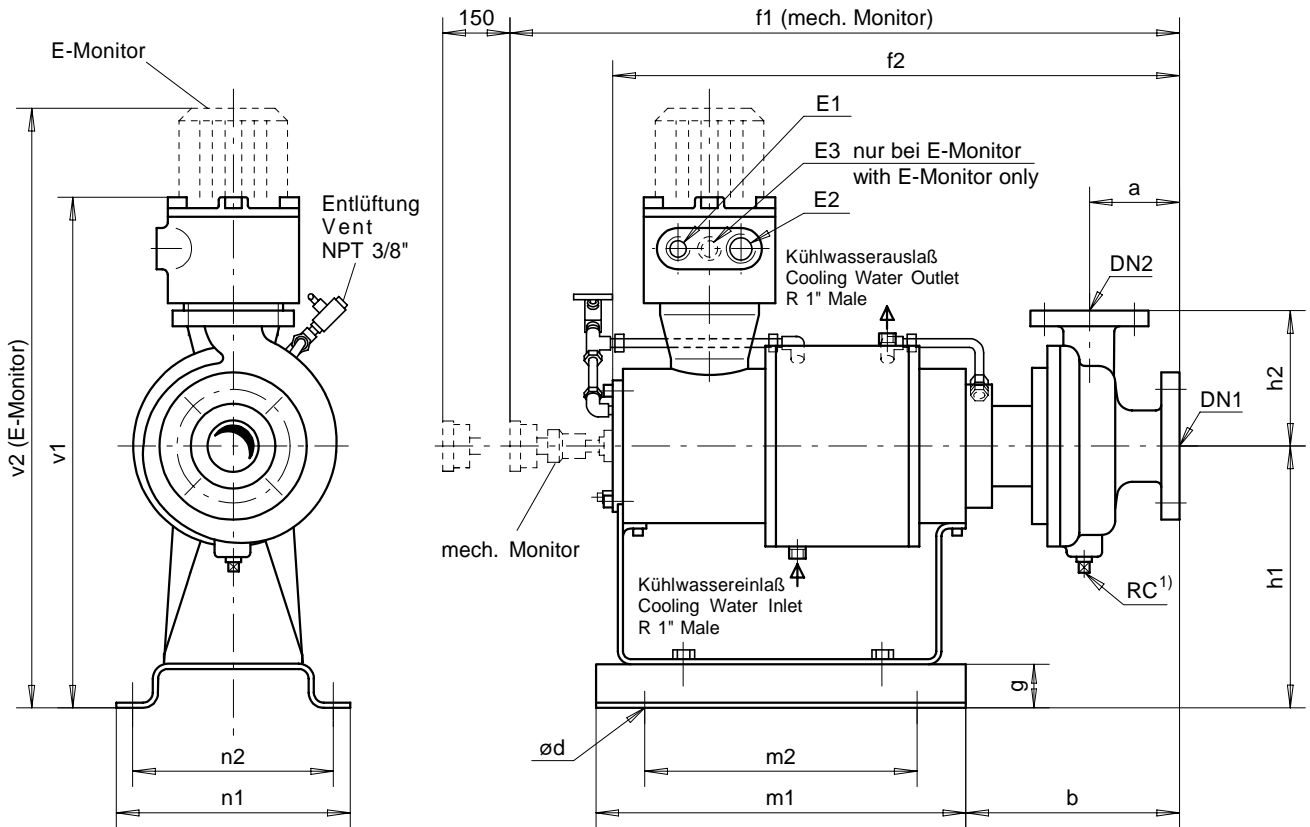

1) Pumpenentleerung für HT auf Anfrage
Casing Drain for HT on Request

* max. 30bar

Maße / Dimensions in [mm]
Gewichte / Weights in [kg]

Modell	DIN DN1	PN40 DN2	ANSI #300 DN1	ANSI #300 DN2	RC	a	b	ød	f1	f2	g	h1	h2	m1	m2	n1	n2	v1	v2	E1	E2	E3	Gew. Wt.
HT23F-D1	65	40	2 1/2"	1 1/2"	1/2"	125	295	19	1040	923	60	350	280	630	530	340	300	735	864	M20	M50	M20	355
HT23F-D2									1070	953				660	560								370
HT24E-D1 *	80	50	3"	2"	1/2"	125	311	19	1056	939	60	350	280	630	530	340	300	735	864	M20	M50	M20	345
HT24E-D2 *									1086	969				660	560								360
HT25C-D1	100	80	4"	3"	1/2"	125	315	19	1060	943	60	350	250	630	530	340	300	735	864	M20	M50	M20	320
HT25C-D2									1090	973				660	560								335
HT25D-D1	100	65	4"	2 1/2"	1/2"	125	315	19	1060	943	60	350	250	630	530	340	300	735	864	M20	M50	M20	325
HT25D-D2									1090	973				660	560								340
HT25E-D1	100	65	4"	2 1/2"	1/2"	125	315	19	1060	943	60	350	315	630	530	340	300	735	864	M20	M50	M20	365
HT25E-D2									1090	973				660	560								380
HT26C-D1	125	100	5"	4"	1/2"	165	387	19	1130	1013	60	350	330	630	530	340	300	735	864	M20	M50	M20	335
HT26C-D2									1162	1045				660	560								345
HT26D-D1	125	100	5"	4"	1/2"	170	390	19	1135	1018	60	350	350	630	530	340	300	735	864	M20	M50	M20	340
HT26D-D2									1165	1048				660	560								350