

# LN - A-Motor

Medium Duty (Gehäusenendruck / Casing Pressure 16bar)

**NIKKISO**

NIKKISO PUMPS EUROPE

Nikkisostrasse • D-63674 Albstadt/Hessen

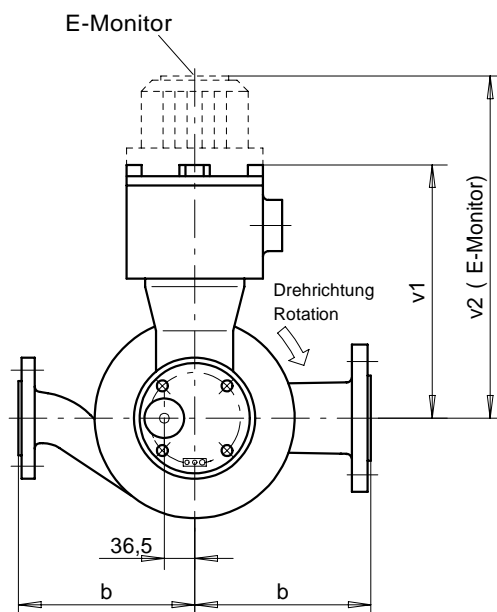
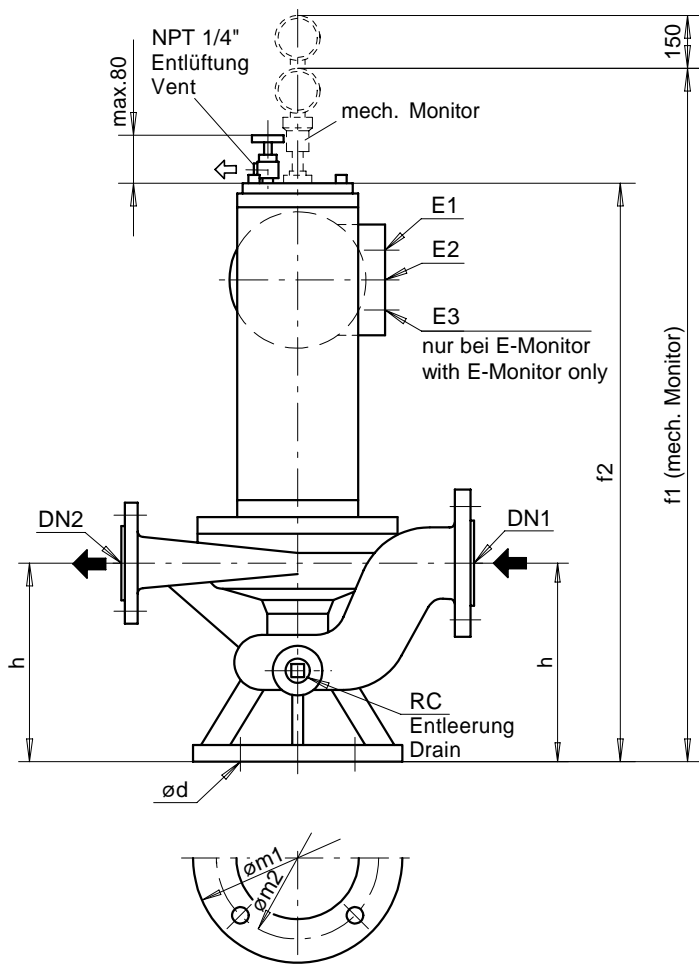

Maße / Dimensions in [mm]  
Gewichte / Weights in [kg]

| Modell   | DIN DN1 | PN40 DN2 | ANSI #300 DN1 | ANSI #300 DN2 | RC   | b   | ød | f1  | f2  | h   | m1  | m2  | v1  | v2  | E1  | E2  | E3  | Gew. Wt. |
|----------|---------|----------|---------------|---------------|------|-----|----|-----|-----|-----|-----|-----|-----|-----|-----|-----|-----|----------|
| LN21A-A1 | 50      | 32       | 2"            | 1 1/2"        | 1/2" | 160 | 15 | 603 | 456 | 130 | 200 | 160 | 270 | 383 | M20 | M32 | M20 | 50       |
| LN21A-A2 |         |          |               |               |      |     |    | 633 | 486 |     |     |     |     |     |     |     |     | 53       |
| LN21A-A3 |         |          |               |               |      |     |    | 663 | 516 |     |     |     |     |     |     |     |     | 55       |
| LN21B-A1 | 50      | 32       | 2"            | 1 1/2"        | 1/2" | 160 | 15 | 602 | 455 | 130 | 200 | 160 | 270 | 383 | M20 | M32 | M20 | 51       |
| LN21B-A2 |         |          |               |               |      |     |    | 632 | 485 |     |     |     |     |     |     |     |     | 54       |
| LN21B-A3 |         |          |               |               |      |     |    | 662 | 515 |     |     |     |     |     |     |     |     | 56       |
| LN21C-A1 | 50      | 32       | 2"            | 1 1/2"        | 1/2" | 180 | 15 | 603 | 456 | 130 | 200 | 160 | 270 | 383 | M20 | M32 | M20 | 54       |
| LN21C-A2 |         |          |               |               |      |     |    | 633 | 486 |     |     |     |     |     |     |     |     | 57       |
| LN21C-A3 |         |          |               |               |      |     |    | 663 | 516 |     |     |     |     |     |     |     |     | 59       |
| LN22B-A1 | 50      | 32       | 2"            | 1 1/2"        | 1/2" | 200 | 15 | 659 | 512 | 180 | 240 | 195 | 270 | 383 | M20 | M32 | M20 | 63       |
| LN22B-A2 |         |          |               |               |      |     |    | 689 | 542 |     |     |     |     |     |     |     |     | 66       |
| LN22B-A3 |         |          |               |               |      |     |    | 719 | 572 |     |     |     |     |     |     |     |     | 68       |
| LN22C-A2 | 50      | 32       | 2"            | 1 1/2"        | 1/2" | 200 | 15 | 684 | 537 | 180 | 240 | 195 | 270 | 383 | M20 | M32 | M20 | 66       |
| LN22C-A3 |         |          |               |               |      |     |    | 714 | 567 |     |     |     |     |     |     |     |     | 68       |
| LN22D-A2 |         |          |               |               |      |     |    | 693 | 546 |     |     |     |     |     |     |     |     | 73       |
| LN22D-A3 | 723     | 576      | 75            |               |      |     |    |     |     |     |     |     |     |     |     |     |     |          |
| LN23B-A2 | 65      | 50       | 2 1/2"        | 2"            | 1/2" | 220 | 15 | 701 | 554 | 180 | 270 | 225 | 270 | 383 | M20 | M32 | M20 | 76       |
| LN23B-A3 |         |          |               |               |      |     |    | 731 | 584 |     |     |     |     |     |     |     |     | 78       |
| LN23C-A3 | 65      | 50       | 2 1/2"        | 2"            | 1/2" | 220 | 15 | 723 | 576 | 180 | 270 | 225 | 270 | 383 | M20 | M32 | M20 | 79       |