

# LY - M-Motor

Medium Duty (Gehäusenendruck / Casing Pressure 40bar)

**NIKKISO**

NIKKISO PUMPS EUROPE

Nikkisostrasse • D-63674 Albstadt/Hessen

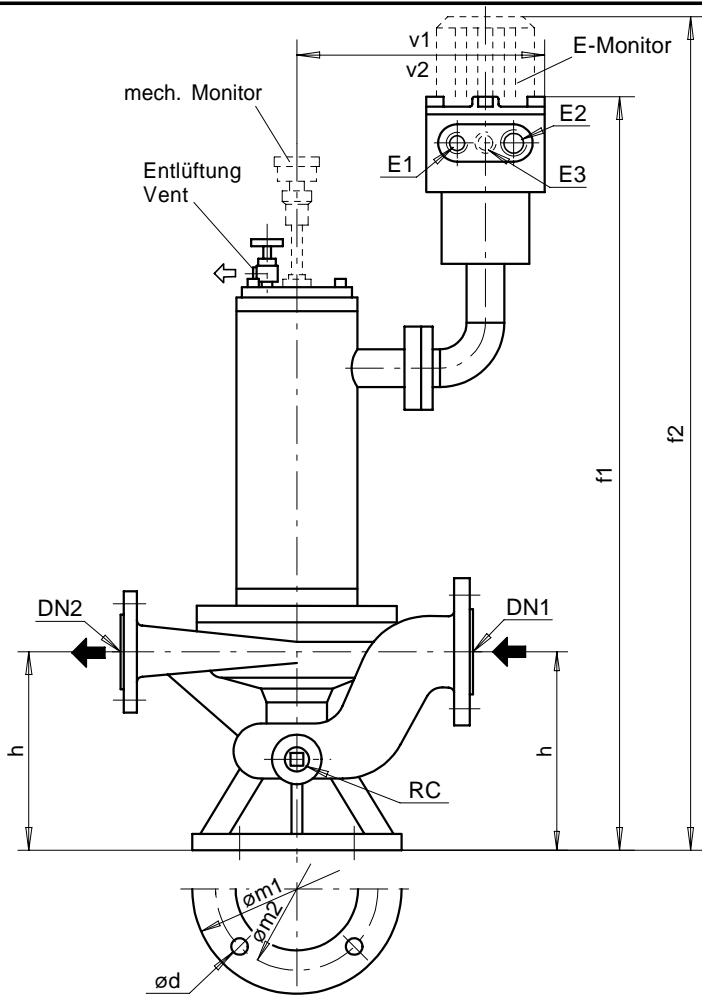

E3 : nur bei E-Monitor  
with E-Monitor only

v1 : Mechanischer Lagermonitor  
Mechanical Bearing Monitor

v2 : E-Monitor

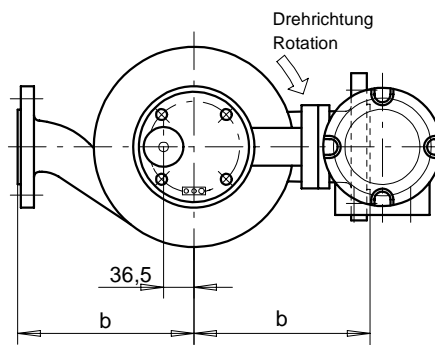

Maße / Dimensions in [mm]  
Gewichte / Weights in [kg]

Modell	DIN DN1	PN40 DN2	ANSI #300 DN1	ANSI #300 DN2	RC	b	ød	f1	f2	h	m1	m2	v1	v2	E1	E2	E3	Gew. Wt.
LY21A-M1																		80
LY21A-M2	50	40	2"	1 1/2"	1/2"	160	15	947	1060	130	200	160	350	359	M20	M32	M20	85
LY21A-M3																		90
LY21B-M1																		80
LY21B-M2	50	40	2"	1 1/2"	1/2"	160	15	946	1059	130	200	160	350	359	M20	M32	M20	85
LY21B-M3																		90
LY21C-M1																		85
LY21C-M2	50	40	2"	1 1/2"	1/2"	180	15	947	1060	130	200	160	350	359	M20	M32	M20	90
LY21C-M3																		95
LY22B-M1																		90
LY22B-M2	50	40	2"	1 1/2"	1/2"	200	15	1003	1116	180	240	195	350	359	M20	M32	M20	95
LY22B-M3																		100
LY22C-M1																		95
LY22C-M2	50	40	2"	1 1/2"	1/2"	200	15	998	1111	180	240	195	350	359	M20	M32	M20	100
LY22C-M3																		105
LY22D-M1																		105
LY22D-M2	50	40	2"	1 1/2"	1/2"	200	15	1007	1120	180	240	195	350	359	M20	M32	M20	110
LY22D-M3																		115
LY22E-M1																		120
LY22E-M2	50	40	2"	1 1/2"	1/2"	240	15	1018	1131	190	240	195	350	359	M20	M32	M20	125
LY22E-M3																		130
LY23B-M1																		100
LY23B-M2	65	50	2 1/2"	2"	1/2"	220	15	1015	1128	180	270	225	350	359	M20	M32	M20	105
LY23B-M3																		110
LY23C-M1																		105
LY23C-M2	65	50	2 1/2"	2"	1/2"	220	15	1007	1120	180	270	225	350	359	M20	M32	M20	110
LY23C-M3																		115
LY23D-M1																		115
LY23D-M2	65	50	2 1/2"	2"	1/2"	240	15	1021	1134	190	270	225	350	359	M20	M32	M20	120
LY23D-M3																		125