

POMPA PER VUOTO AD ANELLO LIQUIDO

LIQUID RING
VACUUM PUMP

AL411D

MODELLO AL411DA / AL411DL



La pompa per vuoto ad anello liquido modello AL411 è del tipo a due stadi per alto vuoto, in esecuzione ad asse nudo o con lanterna di accoppiamento a motore in forma B5, completa di tenute meccaniche. Doppia sopportazione ai lati, versatile nelle prestazioni, raggiunge 33mbar ass., adatta ad aspirare vapori e gas con tracce di liquidi, non necessita di lubrificazione, manutenzione contenuta. Disponibile in versione standard oppure in acciaio inox AISI 316 (parti umide).

The liquid ring vacuum pump model AL411 is two stage type for deep vacuum, bareshaft version or lantern version to be connected to B5 motors, fitted with single mechanical seals. Between bearing impellers, flexible in performance, achieves 33 mbar abs., suitable to suck vapors and gas with liquid carry over, oil free operation, limited maintenance required. Available in standard version or in ss AISI 316 (wetted parts).



Emmecom s.r.l.

Via P. Nenni, 70
20093 Cologno Monzese (MI)
Tel. +39 02 25 33 300 (r.a.)
Fax +39 02 27 307 908
www.emmecomsrl.com
sales@emmecomsrl.com

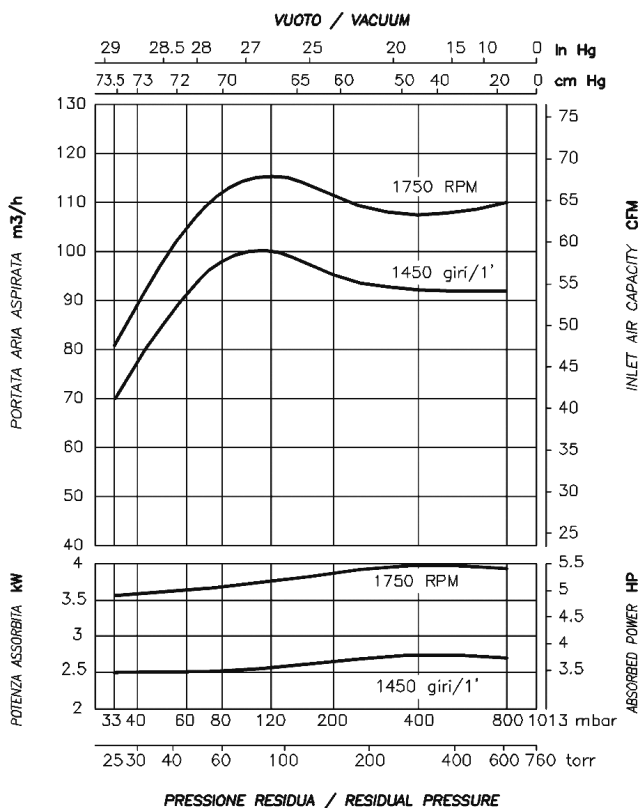

I valori di portata sono riferiti ad aria secca, alla temperatura di 20°C, alla pressione atmosferica di mandata (1013 mbar), e all'impiego di acqua alla temperatura di 15°C. Tolleranza di prestazione $\pm 10\%$. Nell'esecuzione in inox la portata diminuisce del 10%. I dati sopraindicati possono essere variati senza preavviso.

The given capacity values are referred to dry air at the temperature of 20°C, atmospheric discharge pressure (1013 mbar), and of supply of service water at 15°C temperature. Performance tolerance $\pm 10\%$. Stainless steel construction is 10% less performing. The data may change without any notice.

a i r m o v i n g

POMPA PER VUOTO AD ANELLO LIQUIDO

LIQUID RING VACUUM PUMP

MODELLO AL411DA / AL411DL



Dimensioni / Dimensions = mm

AL411DA

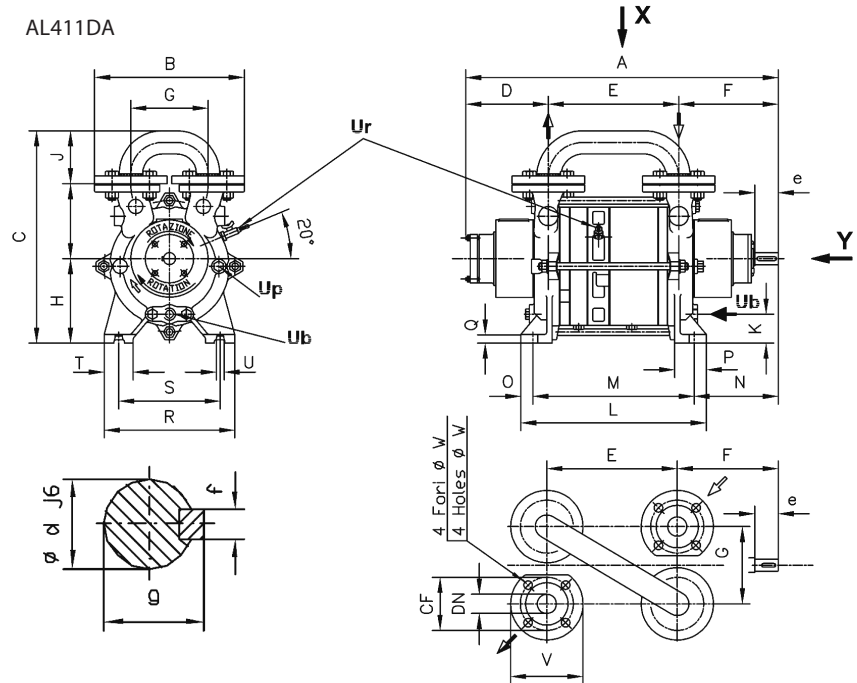

AL411DL

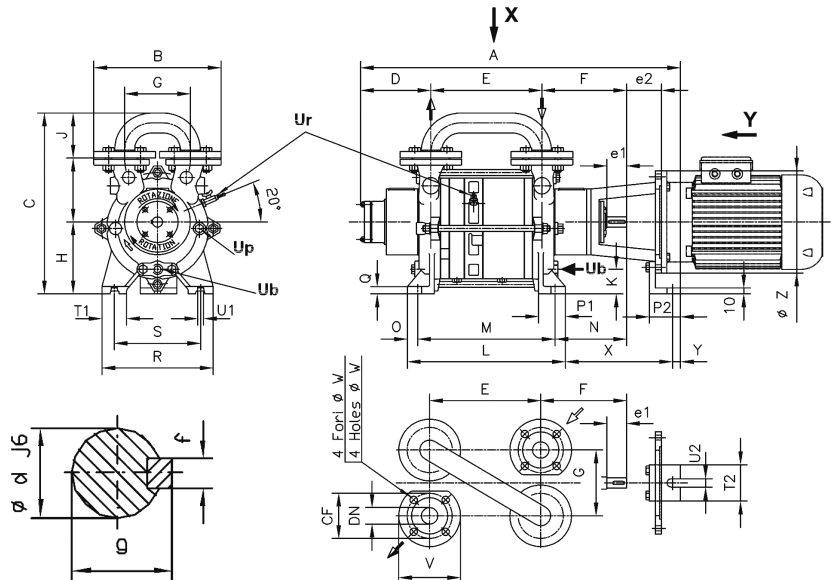

	FLANGE	UNI PN 10			ANSI 150		
		DN	CF	V	W	CF	V
AL411	40 1.1/2"	110	150	18	98.4	150	16

AL411 CONNESSIONI / CONNECTIONS

Ub	1/2" GAS F/NPT M	Attacco per liquido di esercizio Service liquid connection
Ur	1/4" GAS	Drenaggio pompa Pump drain
Up	3/8" GAS F	Rompivuoto Relief valve
d	28	Sporgenza d'albero - Shaft end
e	55	Sporgenza d'albero - Shaft end
f	8	Sporgenza d'albero - Shaft end
g	31	Sporgenza d'albero - Shaft end

- Ub entrata liquido di esercizio
service liquid inlet
- Ur valvola anticavitazione
relief valve
- Up attacco valvola scarico troppo pieno
overflow valve connection

	A	B	C	D	E	F	G	H	I	J	K	L	M	N	O	P	Q	R	S	T	U	Peso totale - Kg Total Weight - Kg
AL411DA	540	310	440	140	230	175	160	175	155	110	60	345	300	140	22.5	65	18	270	210	60	14	75

	Hz	kW	IEC	A	B	C	D	E	F	G	H	I	J	K	L	M	N	O	P1	P2	Q	R	S	T1	T2	U1	U2	X	Y	Z	e2	Peso totale - Kg Total Weight - Kg
AL411DL	50	3	100/4	660	310	440	140	230	175	160	175	155	110	60	345	300	140	23	65	80	18	270	210	60	80	14	14	220	20	250	63	80
AL411DL	60	4	112/4	660	310	440	140	230	175	160	175	155	110	60	345	300	140	23	65	80	18	270	210	60	80	14	14	220	20	250	63	80