

## Industrial Peristaltic Pumps FMP-60/B Data sheet

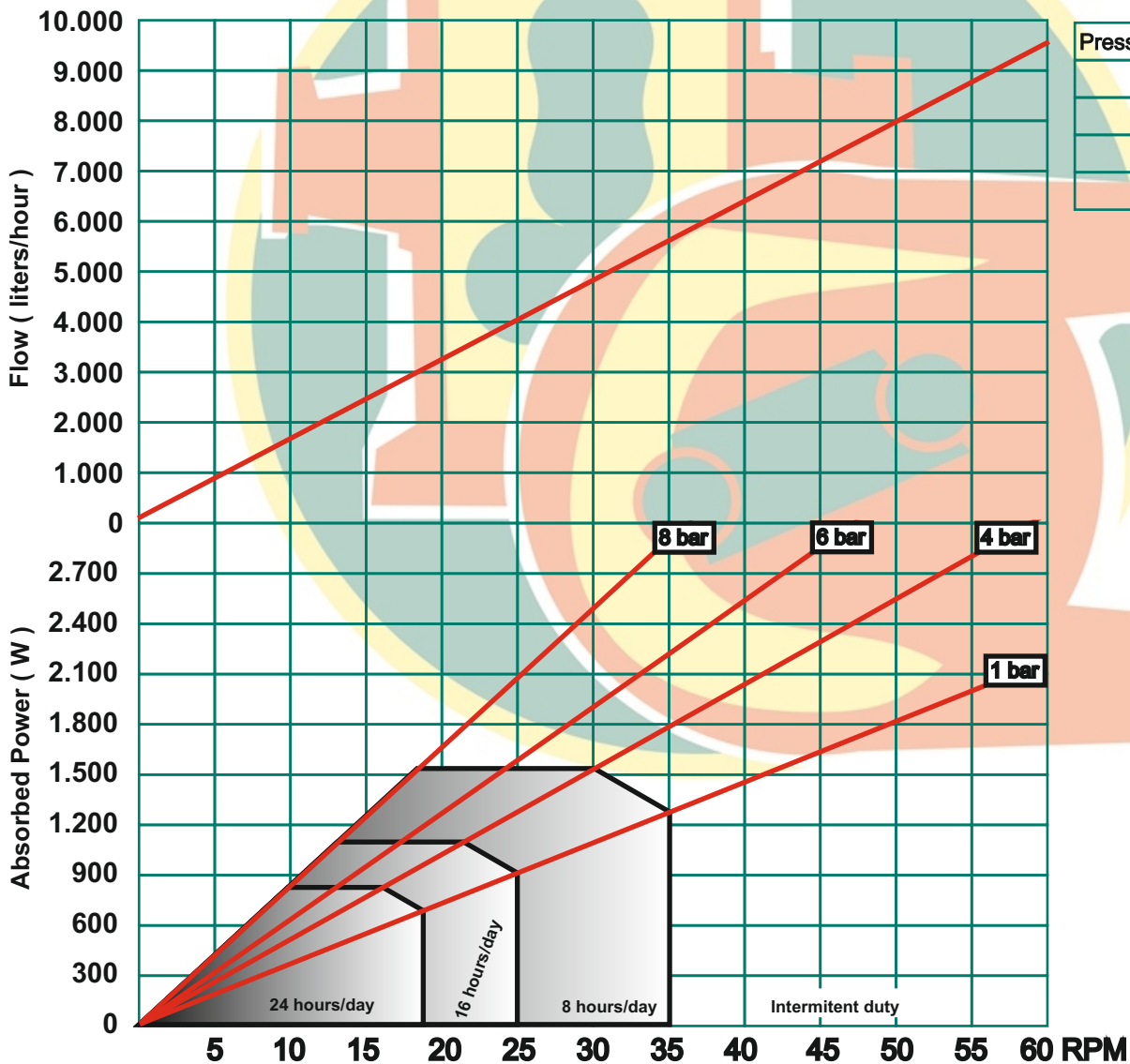

**Capacity:** 3,16 l/rev.  
**Connections:** DN-50  
**Max. Pressure:** 8 bar  
**Rotor system:** Enlarged Rollers  
**Available hoses:** NR  
 NBR  
 EPDM  
 HYPALON  
 NR-A  
 NBR-A  
**Available tubes:** Norprene



Pressure (bar)	Torque (Nm)
1	340
4	500
6	610
8	800



Description	Material	Surface treatment
Pump housing	Cast Iron EN-GJL-250	Polyester powder coated Halar coated ( Optional )
Front cover	Steel F-111 / Polycarbonate	Polyester powder coated Halar coated ( Optional )
Rotor	Nodular Cast Iron EN-GJL-400	Cataforesis
Rollers	Steel F-114 + Polyurethane	--
Base plate	Steel F-111 Stainless Steel AISI-304 ( Optional )	Polyester powder coated --
Connections	Stainless Steel AISI-316 Polypropylene ( Optional ) PVDF ( Optional )	--

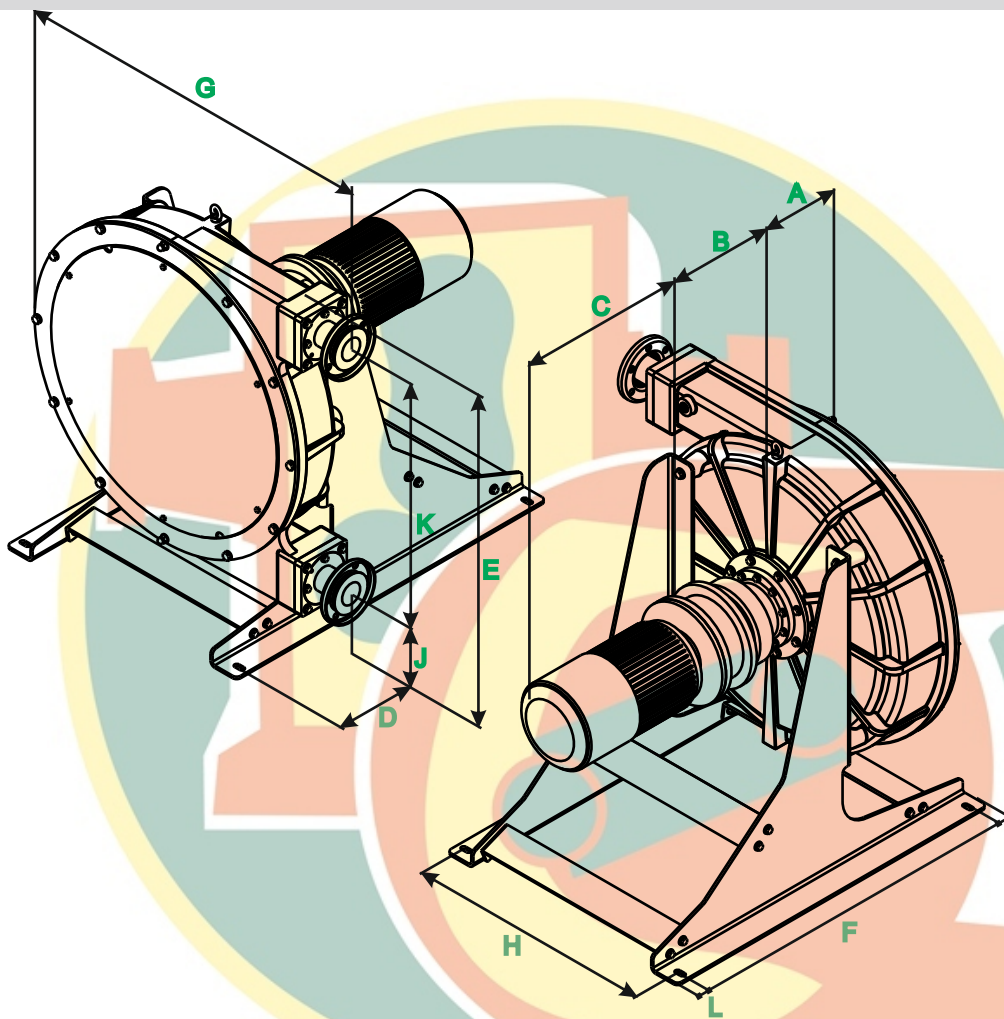

A	B	C	D	E	F	G	H	I	J	K	L
215	*	*	111	805	740	735	500	25	210	510	25

\* To confirm according type and power driver.



Bombas Boyser, S.L. C/. Narcís Monturiol, 24 · Pol. Ind. Can Magre  
Telf.: 93 844 77 78 · 08187 Sta. Eulàlia de Ronçana (BARCELONA)  
[info@boyser.com](mailto:info@boyser.com) · [www.boyser.com](http://www.boyser.com)

