

## Industrial Peristaltic Pumps

### RBT-32/B Data sheet

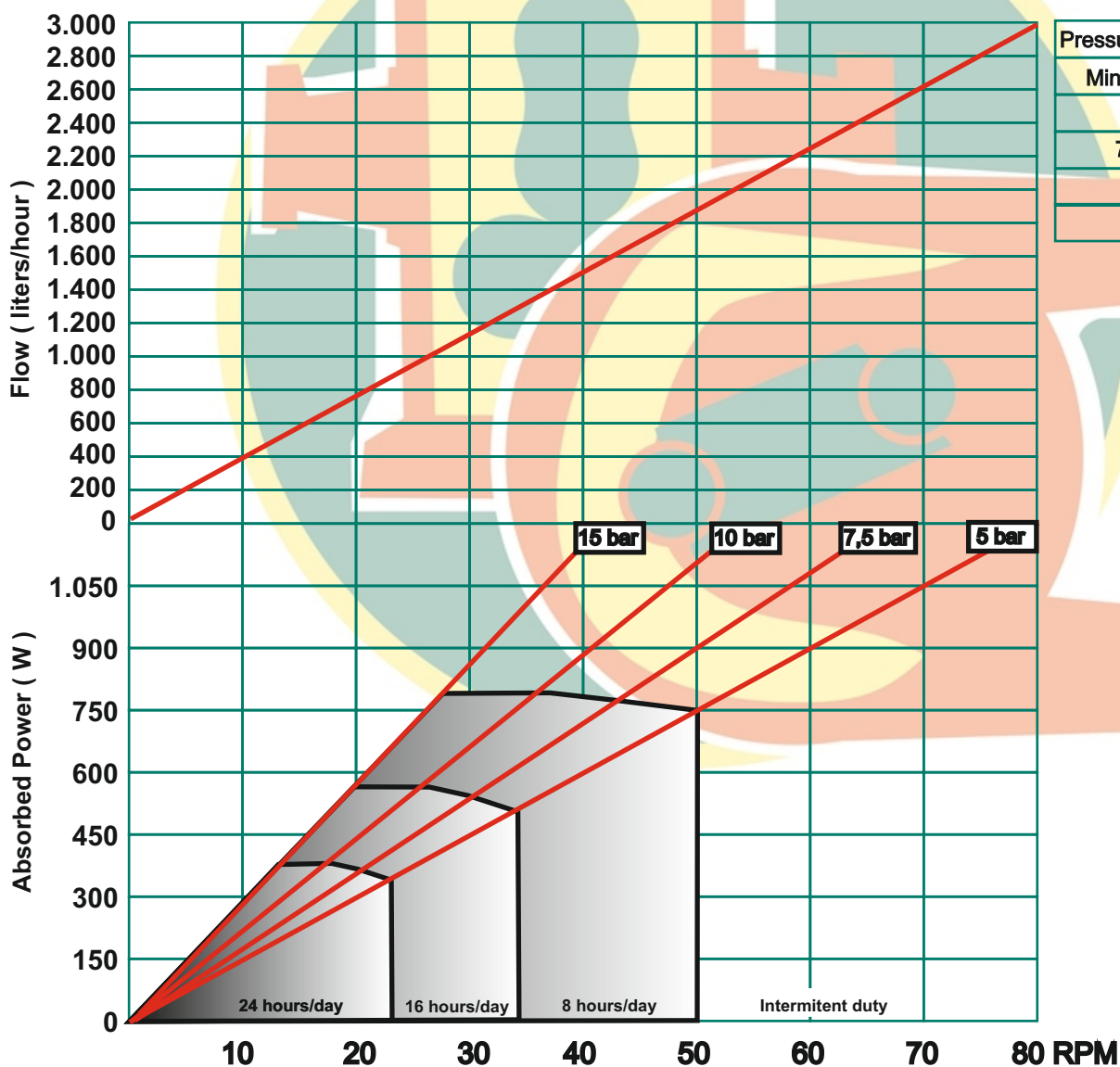

**Capacity:** 0,62 l/rev.  
**Connections:** DN-32  
**Max. Pressure:** 15 bar  
**Rotor system:** Shoes  
**Available hoses:** NR  
 NBR  
 EPDM  
 HYPALON  
 NR-A  
 NBR-A



Description	Material	Surface treatment
Pump housing	Cast Iron EN-GJL-250	Polyester powder coated Halar coated ( Optional )
Front cover	Steel F-111 / Methacrilate	Polyester powder coated Halar coated ( Optional )
Rotor	Nodular Cast Iron EN-GJL-400	Cataforesis
Shoes	Nodular Cast Iron EN-GJL-400	Hardened
Base plate	Steel F-111 Stainless Steel AISI-304 ( Optional )	Polyester powder coated --
Connections	Stainless Steel AISI-316 Polypropylene ( Optional ) PVDF ( Optional )	--

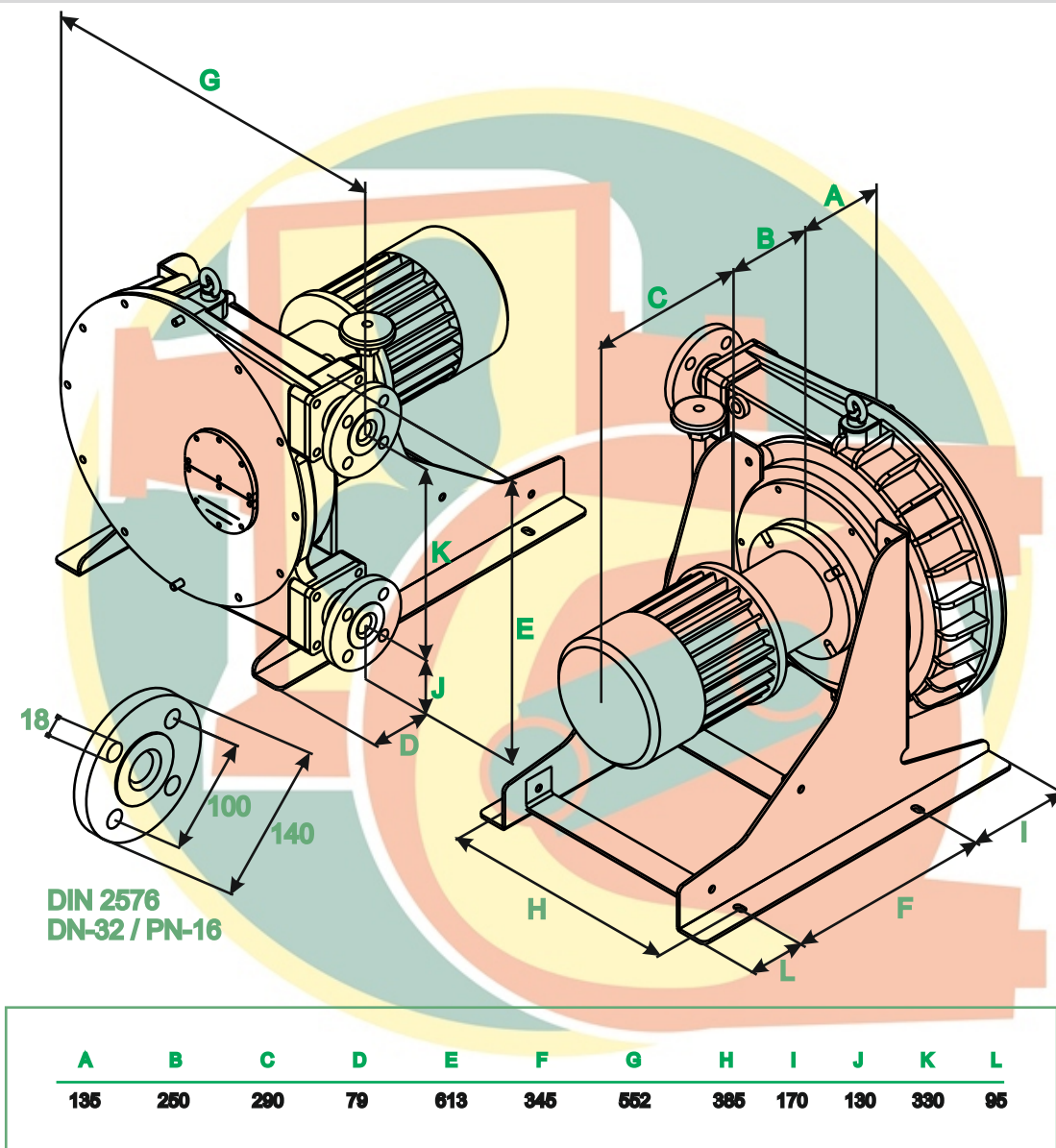

\* To confirm according type and power driver.



Bombas Boyser, S.L. C/ Narcís Monturiol, 24 · Pol. Ind. Can Magre  
Telf.: 93 844 77 78 · 08187 Sta. Eulàlia de Ronçana (BARCELONA)  
[info@boyser.com](mailto:info@boyser.com) · [www.boyser.com](http://www.boyser.com)

