

Industrial Peristaltic Pumps

RBT-40 Data sheet

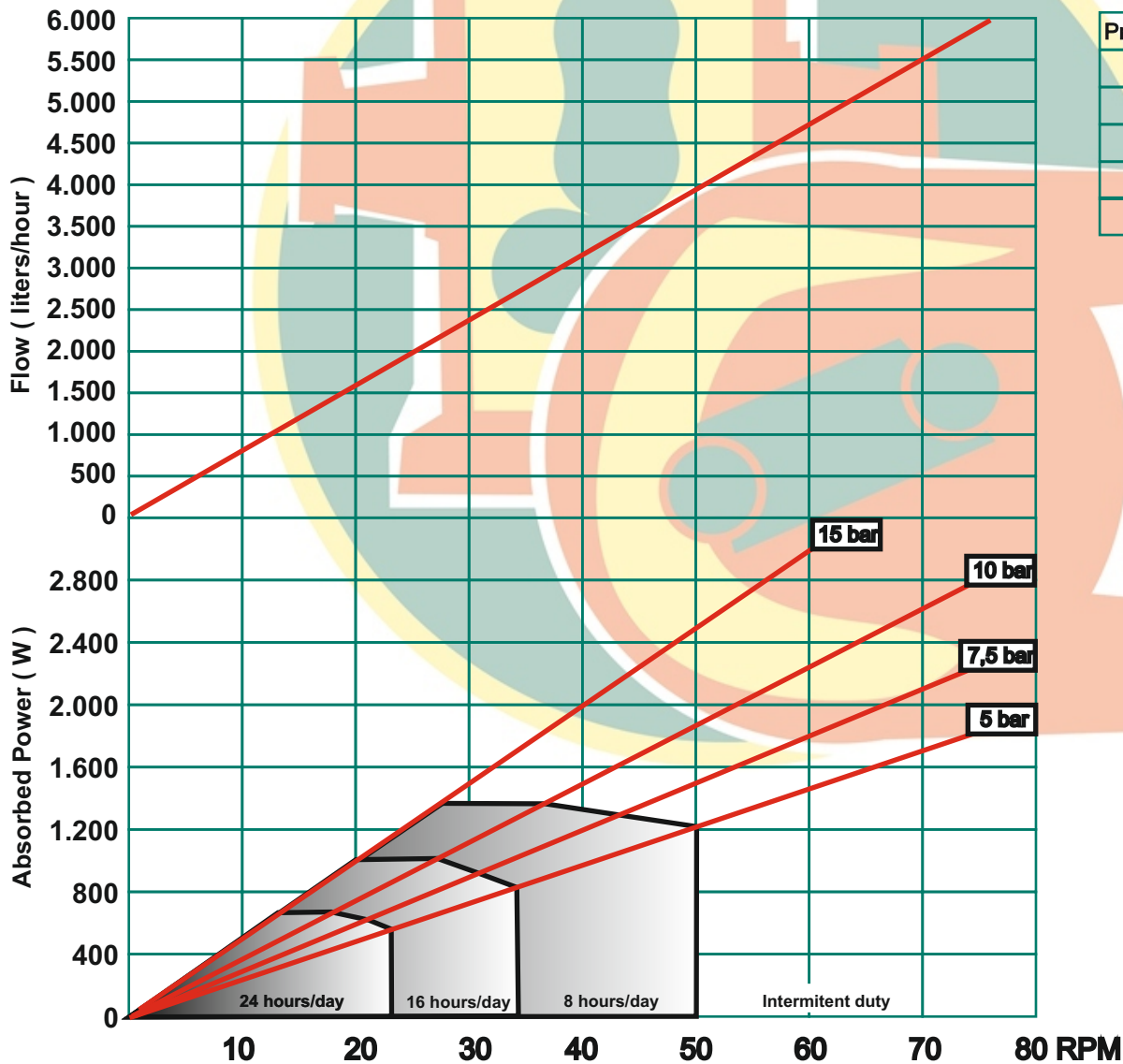

Capacity: 1,33 l/rev.
Connections: DN-40
Max. Pressure: 15 bar
Rotor system: Shoes
Available hoses: NR
 NBR
 EPDM
 HYPALON
 NR-A
 NBR-A



Pressure (bar)	Torque (Nm)
Minimum	310
5	310
7,5	310
10	365
15	480



Description	Material	Surface treatment
Pump housing	Cast Iron EN-GJL-250	Polyester powder coated Halar coated (Optional)
Front cover	Steel F-111 / Methacrilate	Polyester powder coated Halar coated (Optional)
Rotor	Nodular Cast Iron EN-GJL-400	Cataforesis
Shoes	Nodular Cast Iron EN-GJL-400	Hardened
Base plate	Steel F-111 Stainless Steel AISI-304 (Optional)	Polyester powder coated --
Connections	Stainless Steel AISI-316 Polypropylene (Optional) PVDF (Optional)	--

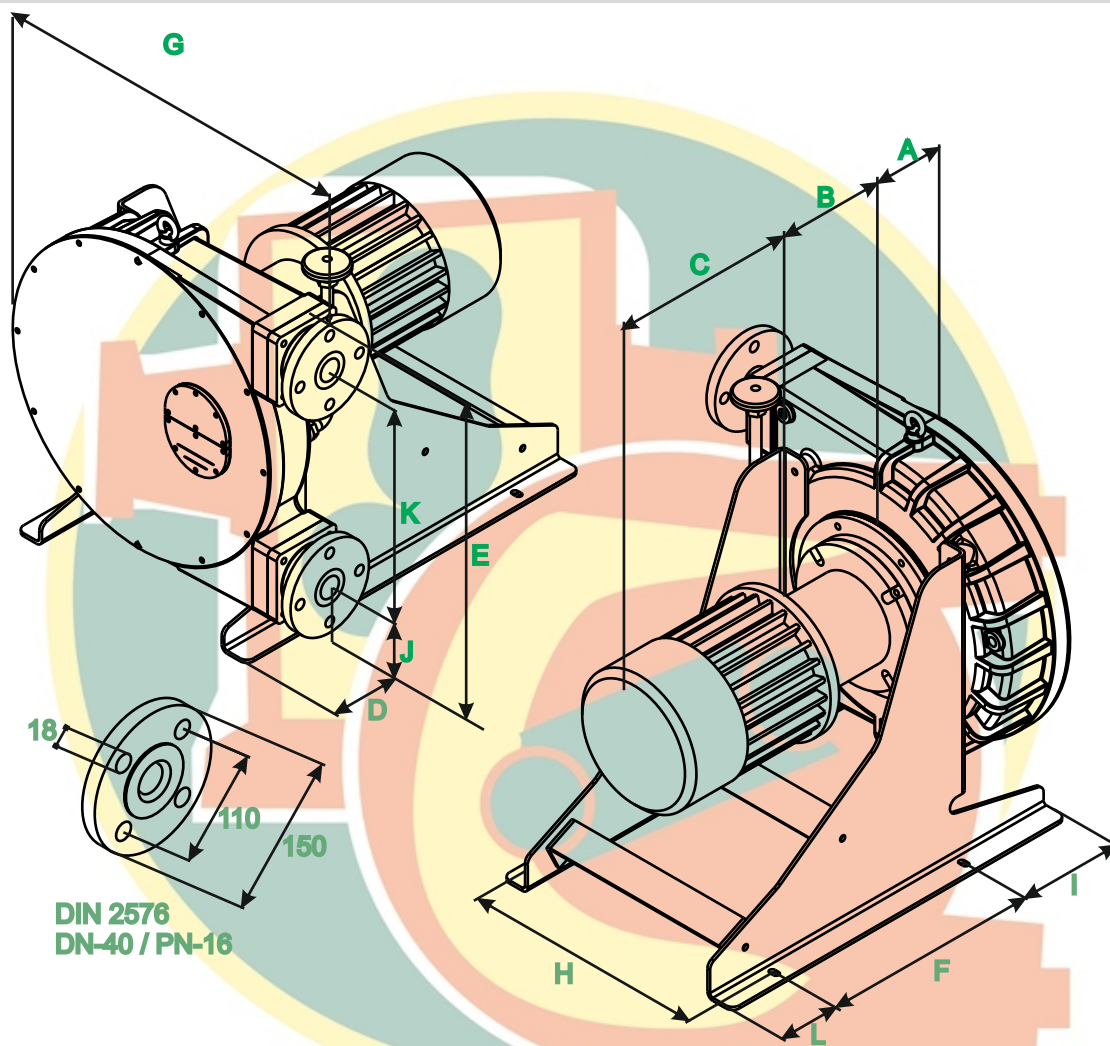

A	B	C	D	E	F	G	H	I	J	K	L
151	•	•	79	645	415	633	456	200	159	412	115

* To confirm according type and power driver.



Bombas Boyser, S.L. C/ Narcís Monturiol, 24 · Pol. Ind. Can Magre
Telf.: 93 844 77 78 · 08187 Sta. Eulàlia de Ronçana (BARCELONA)
info@boyser.com · www.boyser.com

