

Industrial Peristaltic Pumps

RBT-60/B Data sheet

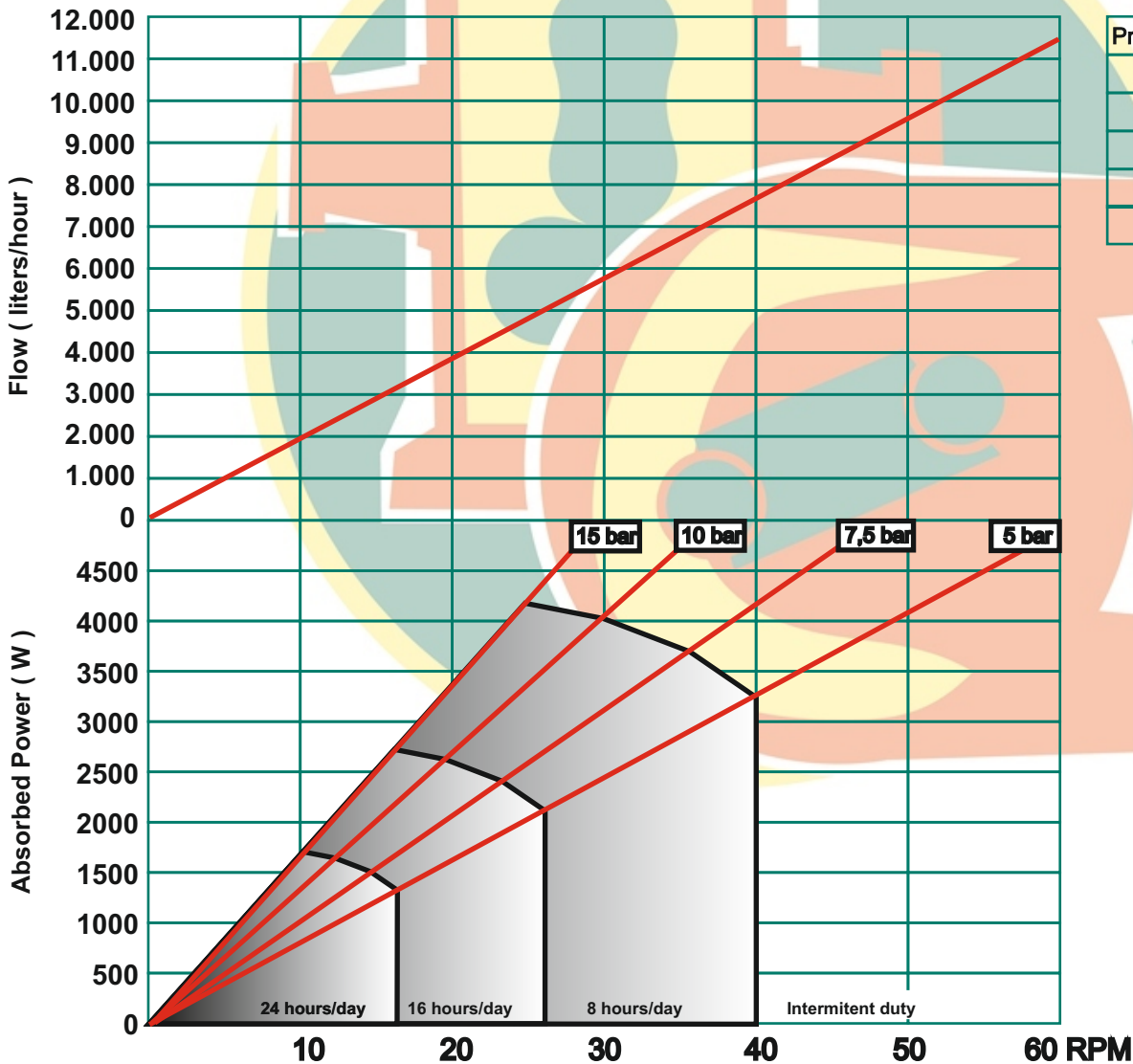

Capacity: 3,61 l/rev.
Connections: DN-50
Max. Pressure: 15 bar
Rotor system: Shoes
Available hoses: NR
 NBR
 EPDM
 HYPALON



Pressure (bar)	Torque (Nm)
Minimum	800
5	800
7,5	1000
10	1300
15	1700



Description	Material	Surface treatment
Pump housing	Cast Iron EN-GJL-250	Polyester powder coated Halar coated (Optional)
Front cover	Steel F-111 / Methacrilate	Polyester powder coated Halar coated (Optional)
Rotor	Nodular Cast Iron EN-GJL-400	Cataforesis
Shoes	Nodular Cast Iron EN-GJL-400	Hardened
Base plate	Steel F-111 Stainless Steel AISI-304 (Optional)	Polyester powder coated --
Connections	Stainless Steel AISI-316 Polypropylene (Optional) PVDF (Optional)	--

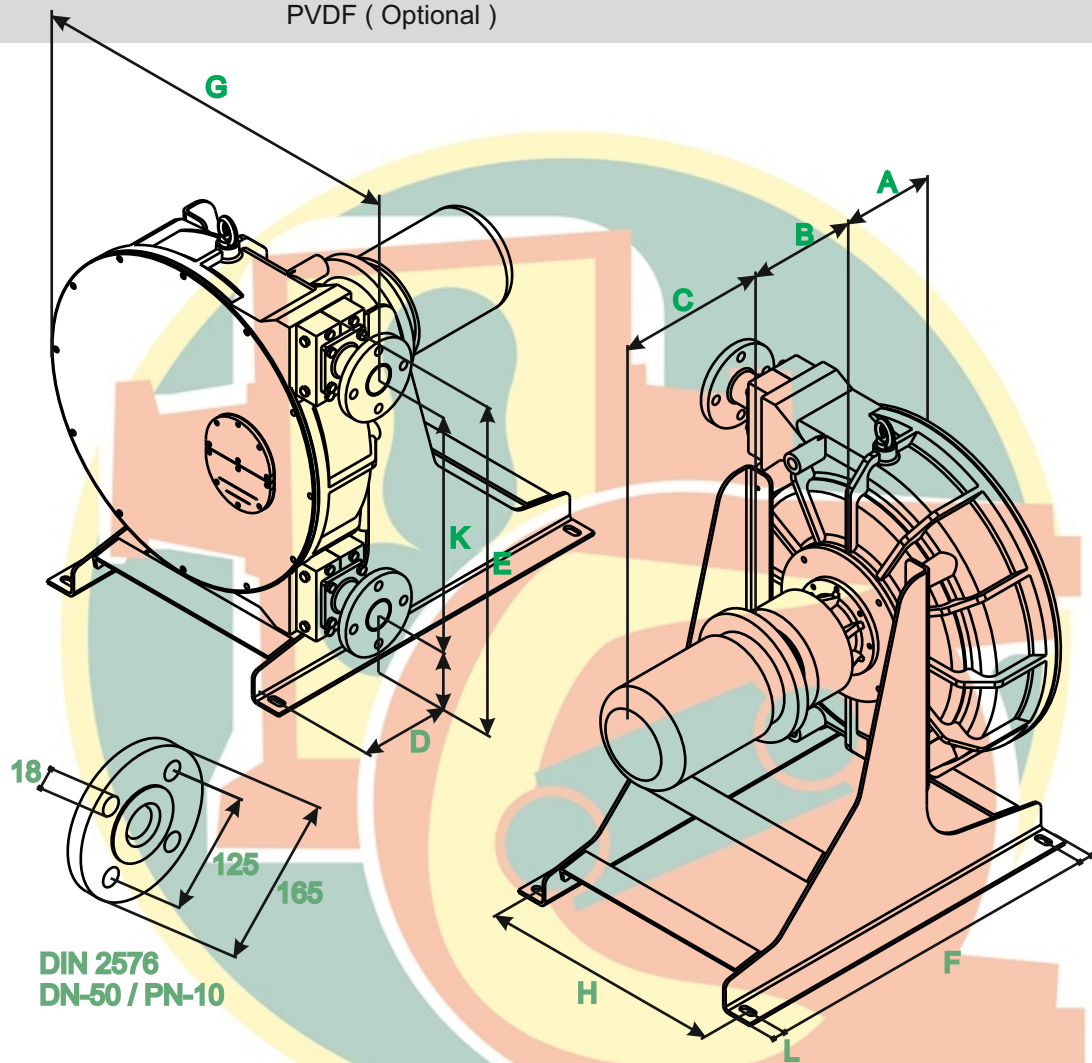

A	B	C	D	E	F	G	H	I	J	K	L
215	•	•	111	805	740	735	500	25	210	510	25

* To confirm according type and power driver.



Bombas Boyser, S.L. C/. Narcís Monturiol, 24 · Pol. Ind. Can Magre
Telf.: 93 844 77 78 · 08187 Sta. Eulàlia de Ronçana (BARCELONA)
info@boyser.com · www.boyser.com

