

Industrial Peristaltic Pumps

RBT-70 Data sheet

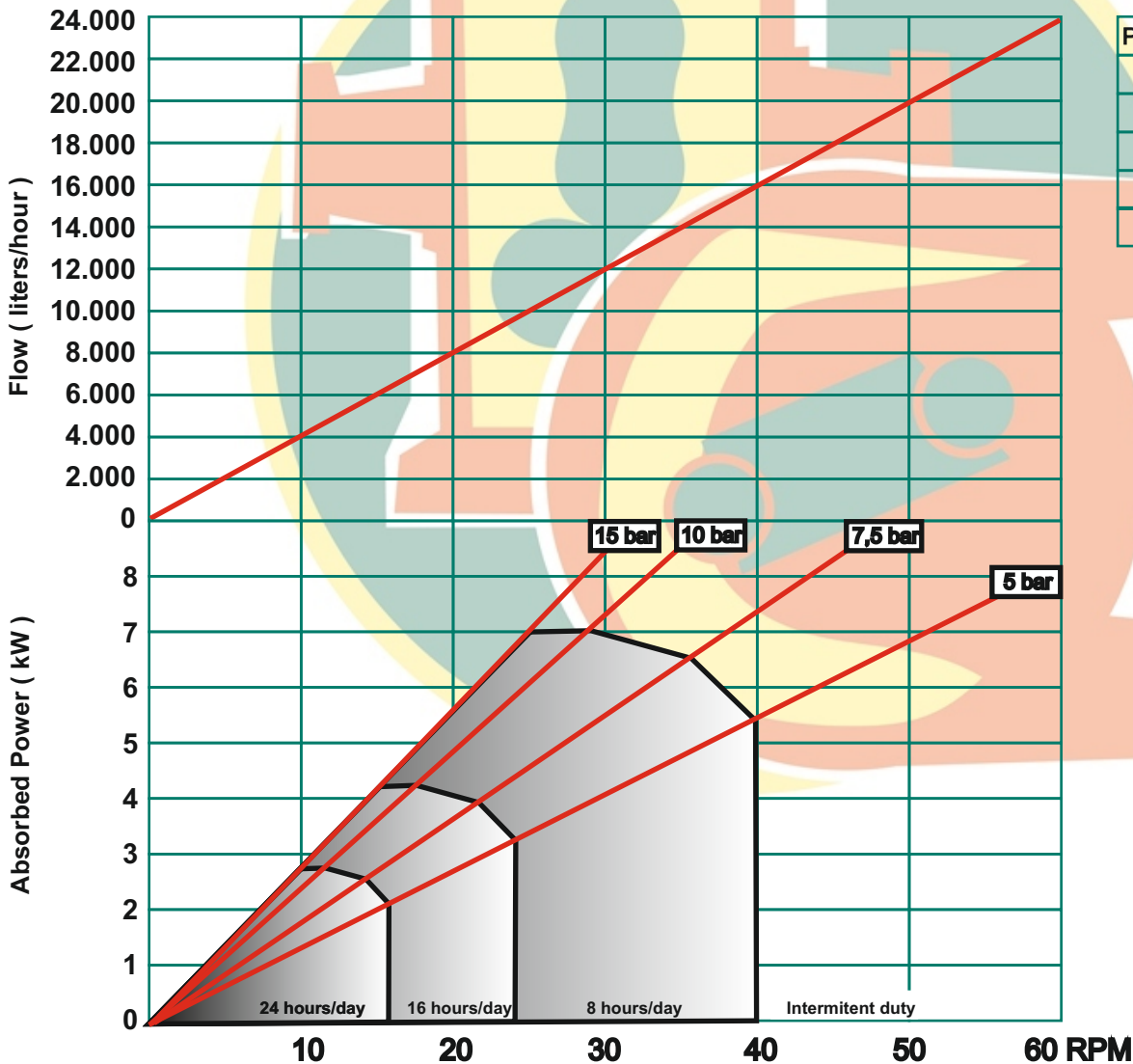

Capacity:	6,7 l/rev.
Connections:	DN-65
Max. Pressure:	15 bar
Rotor system:	Shoes
Available hoses:	NR NBR EPDM HYPALON



Pressure (bar)	Torque (Nm)
Minimum	1200
5	1300
7,5	1800
10	2300
15	2800



Description	Material	Surface treatment
Pump housing	Cast Iron EN-GJL-250	Polyester powder coated Halar coated (Optional)
Front cover	Steel F-111 / Methacrilate	Polyester powder coated Halar coated (Optional)
Rotor	Nodular Cast Iron EN-GJL-400	Cataforesis
Shoes	Nodular Cast Iron EN-GJL-400	Hardened
Base plate	Steel F-111 Stainless Steel AISI-304 (Optional)	Polyester powder coated --
Connections	Stainless Steel AISI-316 Polypropylene (Optional) PVDF (Optional)	--

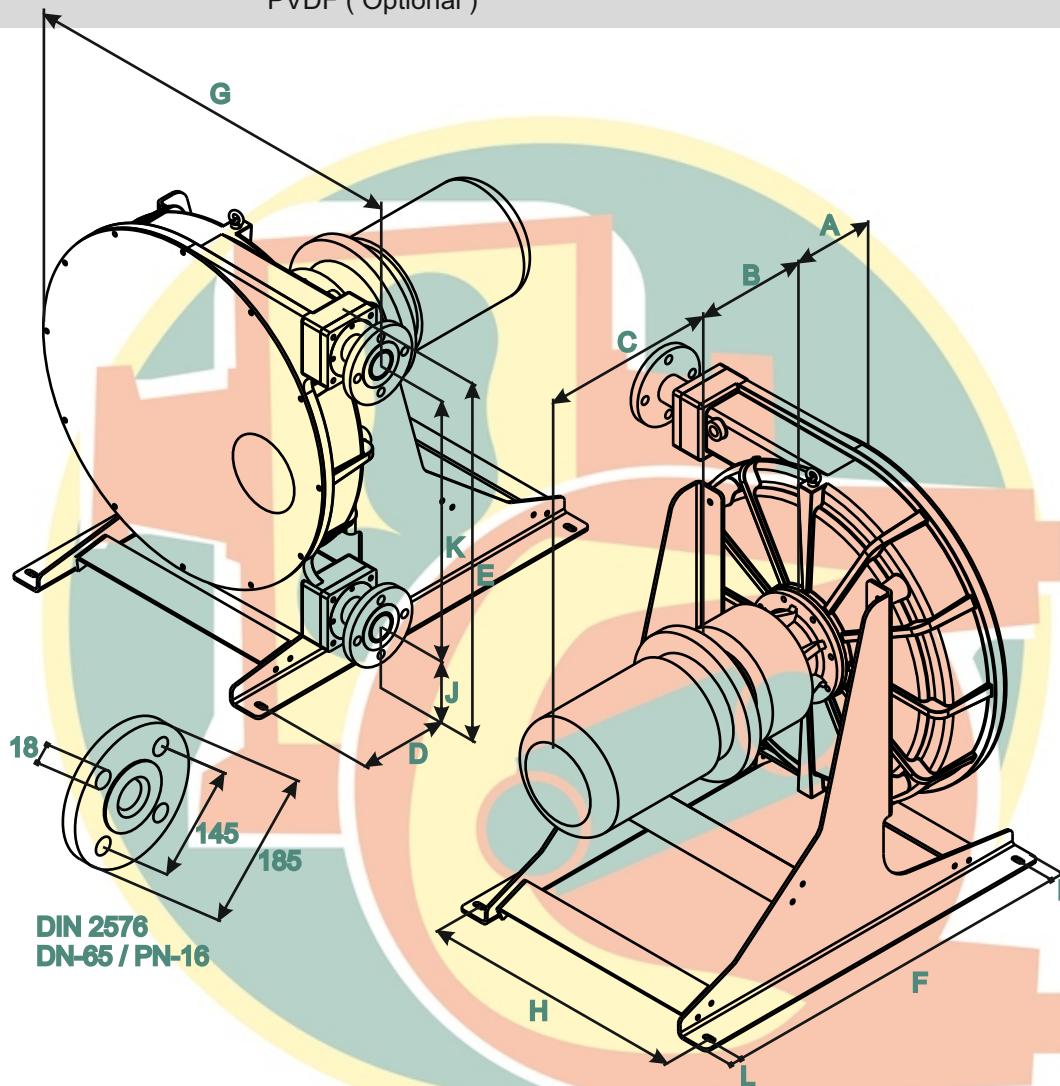

A	B	C	D	E	F	G	H	I	J	K	L
215	*	*	250	1124	1065	1100	790	40	240	784	40

* To confirm according type and power driver.



Bombas Boyser, S.L. C/ Narcís Monturiol, 24 · Pol. Ind. Can Magre
Telf.: 93 844 77 78 · 08187 Sta. Eulàlia de Ronçana (BARCELONA)
info@boyser.com · www.boyser.com

