

Rosemount™ 8800D Series Vortex Flowmeter



HART® and FOUNDATION™ Fieldbus Protocols

- All welded, non-clog design provides maximum performance, reliability and enhanced safety by eliminating ports and gaskets. No seals, just steel.
- CriticalProcess™ Vortex eliminates bypass piping and optimizes safety during maintenance.
- Available with optional multivariable output. Internal temperature compensation provides cost-effective saturated steam and liquid mass flow measurement.
- Adaptive Digital Signal Processing (ADSP) provides vibration immunity and flow range optimization.
- Reducer™ Vortex extends the measurable flow range, reduces installation costs, and minimizes project risk.
- Simplified troubleshooting through device diagnostics and meter verification.
- Available in wafer, flanged, dual, reducer and high pressure designs.



The Rosemount 8800D delivers reliability and maximum process availability

- Rosemount Reliability -The 8800D Vortex eliminates impulse lines, ports, and gaskets to improve reliability.
- Non-clog Design - Unique all welded, gasket-free construction which has no ports or crevices that can clog.
- Vibration Immunity - Mass balancing of the sensor system, and Adaptive Digital Signal Processing (ADSP) provide vibration immunity.
- Replaceable Sensor - The sensor is isolated from the process and can be replaced without breaking the process seal. All line sizes use the same sensor design allowing a single spare to serve every meter.
- Simplified Troubleshooting - Device Diagnostics enable field verification of meter electronics and sensor without process shutdown.

Contents

Ordering Information	8	Product Certifications	31
Specifications	15	Dimensional Drawings	37
Typical Flow Ranges	20		

The Rosemount 8800D CriticalProcess Vortex increases process availability and enhances overall safety

- Eliminate bypass piping for critical process installations
Traditional vortex installations in critical applications include a bypass line to allow process fluid to be re-directed around the vortex flow meter during routine sensor maintenance. Rosemount's unique non-wetted sensor can be installed without bypass piping, even in the most difficult process environments.
- Improve process availability
Eliminate the need to shut down the process during routine maintenance and meter verification.
- Enhances safety in hazardous process fluid applications
A needle valve enables access to the sensor cavity to verify that no process fluid is present.
- Available in Flanged, Reducer, and Dual Vortex meter designs in 1- through 12-in. meter body sizes for ASME B16.5 flange connections. Available in 40 mm through 300 mm meter body sizes for EN 1092-1 and JIS B2220 flange connections.



Reduce installed costs, simplify installation and improve performance in liquid and steam flow applications with the Rosemount 8800D MultiVariable



- Available with flow computer for additional functionality. Integrating the MultiVariable Vortex with a pressure transmitter for full pressure and temperature compensation of superheated steam and various gases provides the following additional functionality:
 - Remote Communications
 - Heat Flow Calculations
 - Remote Totalization
 - Peak Demand Calculation
 - Data Logging Capabilities

See Product Data Sheet 00813-0100-4005 for more information on the Rosemount Flow Computer.



- MultiVariable Vortex Design
Incorporates temperature sensor into the vortex meter using the shedder bar as a thermowell, which keeps the vortex and temperature sensors isolated from process for easy verification and replacement.
- Temperature compensated liquids allows for precision measurement of high temperature liquids by correcting the liquid density as the process temperature changes. Select from water or enter up to 5 temperature and density pairs to accommodate any liquid type. New units of measure such as standard barrels, SBBL, are selectable in the corrected volumetric flow measurement mode. Water density calculations consistent with IAPWS IF-97.
- Temperature compensated capability for saturated steam calculates density from measured process temperature and uses the calculated density to provide a temperature compensated mass flow. On-board ASME steam tables.
- Reduces installed costs
MultiVariable Vortex eliminates the need for an external thermowell and temperature sensor.
- Available with flanged and Reducer Vortex in 1¹/₂- through 12-in. meter body sizes. To order meter with temperature compensated liquids, include HR5 or HR7 and MTA in the model string.

Maximum reliability and reduced installation complexity with the Armored Remote Cable

- Improved protection against abrasion, impact, and moisture.
- Available in 10, 20, 33, 50, and 75 foot lengths.
- Two cable glands are provided to securely connect the remote cable to transmitter and meter body.
- The cable gland material will match the material of construction of the mating parts at both the meter body end and transmitter end. The cable gland that connects to the meter body will utilize a stainless steel gland and the cable gland material at the electronics end will be either aluminum or stainless steel depending on the material of the electronics housing that is ordered.



Detect process fluid changes with SMART Fluid Diagnostics

Oil and gas separators

- Remotely detect when your separator dump valve allows gas to pass through your water dump leg.
- Selectable alert modes (digital, analog or pulse) signal when gas flow is detected.

Steam, nitrogen, or air blow down

- Control your clean in place (CIP) or blow down cycles with a single meter that measures the flow rate of your primary process fluid as well as the change from liquid to gas flow.
- Set your control system to control down cycle based on alert from in-line vortex meter.
- Selectable alert modes (digital, analog or pulse) signal when gas flow is detected.



Rosemount 8800D Vortex Flowmeter with FOUNDATION Fieldbus

The software for the 8800D Flowmeter with FOUNDATION Fieldbus permits remote testing and configuration using any FOUNDATION Fieldbus-compliant host, such as the DeltaV™ system from Emerson Process Management.

Transducer block

The transducer block calculates flow from sensor frequency. The calculation includes information about damping, shedding frequency, K-factor, process fluid, pipe ID, and diagnostics.

Resource block

The resource block contains physical transmitter information, including available memory, manufacturer identification, device type, software tag, and unique identification.

Backup Link Active Scheduler (LAS)

The transmitter is classified as a device link master. A device link master can function as an LAS if the current link master device fails or is removed from the segment.

The host or other configuration tool is used to download the schedule for the application to the link master device. In the absence of a primary link master, the transmitter will claim the LAS and provide permanent control for the H1 segment.

Diagnostics

The transmitter automatically performs continuous self-diagnostics. The user can perform on-line testing of the transmitter digital signal. Advanced simulation diagnostics are available. This enables remote verification of the electronics via a flow signal generator built into the electronics. The sensor strength value can be used to view the process flow signal and provide information regarding filter settings.

FOUNDATION Fieldbus function blocks

Analog input

The AI function block processes the measurement and makes it available to other function blocks. The AI function block also allows filtering, alarming, and engineering unit changes.

The 8800D Flowmeter with FOUNDATION Fieldbus comes with five AI function blocks. Two of the AI function blocks, flow and signal strength, come as standard. Three additional AI function blocks are available when the MTA option is selected: electronics temperature, process temperature, and process density. Note that process density is only available when the process fluid is configured as temperature compensated saturated steam, shown as TComp Sat Steam in the device.

Proportional/Integral/Derivative

The optional PID function block provides a sophisticated implementation of the universal PID algorithm. The PID function block features input for feed forward control, alarms on the process variable, and control deviation. The PID type (series or Instrument Society of America [ISA]) is user-selectable on the derivative filter.

Integrator

The standard integrator block is available for totalization of flow.

Arithmetic

The standard arithmetic block is available for various computations.

Setup

Basic setup requires connecting the transmitter to a fieldbus network or Field Communicator. The FOUNDATION Fieldbus-compliant host will automatically establish communication with the device.

The Rosemount 8800D Flowmeter can be easily configured using the DeltaV system. User-configurable parameters include:

- Tag
- Scaling and units
- Process fluid type
- Damping
- Fixed process density
- Pipe inside diameter (ID)⁽¹⁾
- Fixed process temperature⁽¹⁾

Tagging information can be entered into the transmitter to allow identification and a physical description. 32-character tags are provided for identification of the transmitter and each function block.

(1) Process temperature and pipe ID have known effects on the K-factor. The 8800D software automatically accounts for these effects by compensating the K-factor.

Ordering Information

Table 1. Rosemount 8800D Vortex Flowmeter

★ The Standard offering represents the most common options. The starred options (★) should be selected for best delivery.

The Expanded offering is subject to additional delivery lead time.

Model	Product description	
8800D	Vortex Flowmeter	
Meter style		
F	Flanged style	★
W	Wafer style	★
R	Reducer Style (Flanged style only)	★
D	Dual-sensor style (Flanged style only)	
Line size		
005	1/2-in. (15 mm) (Not available for Rosemount 8800DR)	★
010	1-in. (25 mm)	★
015	1 1/2-in. (40 mm)	★
020	2-in. (50 mm)	★
030	3-in. (80 mm)	★
040	4-in. (100 mm)	★
060	6-in. (150 mm)	★
080	8-in. (200 mm)	★
100	10-in. (250 mm)	
120	12-in. (300 mm)	
Wetted materials		
S	316 wrought stainless and CF-3M cast stainless Note: Material of construction is 316/316L	★
H	UNS N06022 wrought Nickel Alloy; CW2M cast Nickel Alloy Note: See Table 2 .	
C	A105 forged carbon steel and WCB cast carbon steel	
L	LF2 forged carbon steel and LCC cast carbon steel	
D ⁽¹⁾	UNS S32760 wrought duplex stainless steel and 6A cast duplex stainless steel	
Flange or alignment ring size		
A1	ASME B16.5 (ANSI) RF Class 150	★
A3	ASME B16.5 RF Class 300	★
K1	EN 1092-1 PN 16 (PN 10/16 for wafer style) Type B1	★
K3	EN 1092-1 PN 40 (PN 25/40 for wafer style) Type B1	★
A6	ASME B16.5 RF Class 600	
A7 ⁽²⁾	ASME B16.5 RF Class 900	
A8 ⁽³⁾	ASME B16.5 RF Class 1500	
B1 ⁽⁴⁾	ASME B16.5 RTJ Class 150 for flange-style only	

Table 1. Rosemount 8800D Vortex Flowmeter (continued)

★ The Standard offering represents the most common options. The starred options (★) should be selected for best delivery.

The Expanded offering is subject to additional delivery lead time.

B3	ASME B16.5 RTJ Class 300 for flange-style only	
B6	ASME B16.5 RTJ Class 600 for flange-style only	
B7 ⁽²⁾	ASME B16.5 RTJ Class 900 for flange-style only	
B8 ⁽³⁾	ASME B16.5 RTJ Class 1500 for flange-style only	
C1	ASME B16.5 RF Class 150, smooth finish	
C3	ASME B16.5 RF Class 300, smooth finish	
C6	ASME B16.5 RF Class 600, smooth finish	
C7 ⁽²⁾	ASME B16.5 RF Class 900, smooth finish	
C8 ⁽³⁾	ASME B16.5 RF Class 1500, smooth finish	
K0	EN 1092-1 PN 10 Type B1	
K2	EN 1092-1 PN 25 Type B1	
K4	EN 1092-1 PN 63 Type B1	
K6	EN 1092-1 PN 100 Type B1	
K7 ⁽²⁾	EN 1092-1 PN 160 Type B1	
L0	EN 1092-1 PN 10 Type B2	
L1	EN 1092-1 PN 16 (PN 10/16 for wafer style) Type B2	
L2	EN 1092-1 PN 25 Type B2	
L3	EN 1092-1 PN 40 (PN 25/40 for wafer style) Type B2	
L4	EN 1092-1 PN 63 Type B2	
L6	EN 1092-1 PN 100 Type B2	
L7 ⁽²⁾	EN 1092-1 PN 160 Type B2	
M0	EN 1092-1 PN 10 Type D for flange style only	
M1	EN 1092-1 PN 16 Type D for flange style only	
M2	EN 1092-1 PN 25 Type D for flange style only	
M3	EN 1092-1 PN 40 Type D for flange style only	
M4	EN 1092-1 PN 63 Type D for flange style only	
M6	EN 1092-1 PN 100 Type D for flange style only	
M7 ⁽²⁾	EN 1092-1 PN 160 Type D for flange style only	
J1	JIS 10K	
J2	JIS 20K	
J4	JIS 40K	
W1 ⁽⁵⁾	Weld End, Schedule 10S	
W4 ⁽⁵⁾	Weld End, Schedule 40S	
W8 ⁽⁵⁾	Weld End, Schedule 80S	
W9 ⁽⁴⁾⁽⁵⁾	Weld End, Schedule 160S	

Table 1. Rosemount 8800D Vortex Flowmeter (continued)

★ The Standard offering represents the most common options. The starred options (★) should be selected for best delivery.

The Expanded offering is subject to additional delivery lead time.

Sensor process temperature range		
N	Standard: -40 to 450°F (-40 to 232°C)	★
E	Extended: -330 to 800°F (-200 to 427°C)	★
S	Severe Service: -330 to 800 °F (-200 to 427 °C)	
Conduit entry		
1	1/2 -14 NPT – Aluminum Housing	★
2	M20 x 1.5 – Aluminum Housing	★
3	PG 13.5 – Aluminum Housing	★
4	G ^{1/2} (One Conduit Entry) – Aluminum Housing	★
5	G ^{1/2} (Two Conduit Entries) – Aluminum Housing	★
6 ⁽⁶⁾	1/2 - 14 NPT - SST Housing	
7 ⁽⁶⁾	M20 x 1.5 - SST Housing	
Outputs		
D	4-20 mA digital electronics (HART protocol)	★
P	4-20 mA digital electronics (HART protocol) with scaled pulse	★
F	FOUNDATION Fieldbus digital signal	★
Calibration		
1	Flow calibration	★
Options		
Multivariable options		
MTA ⁽⁷⁾	Multivariable output with Integral Temperature Sensor	
Hazardous locations certifications		
E5	FM Explosion-proof; Dust Ignition-proof	★
I5	FM Intrinsically Safe; Non-incendive	★
IE ⁽⁸⁾	FM FISCO Intrinsically Safe	★
K5	FM Explosion-proof; Intrinsically Safe; Non-incendive; Dust Ignition-proof	★
E6	CSA Explosion-proof; Division 2 Dust Ignition-proof	★
I6	CSA Intrinsically Safe	★
IF ⁽⁸⁾	CSA FISCO Intrinsically Safe	★
K6	CSA Explosion-proof; Intrinsically Safe; Division 2; Dust-Ignition-proof	★
KB	FM and CSA Explosion-proof, Dust Ignition-proof, Intrinsically Safe, Non-incendive	★
E1	ATEX Flameproof	★
I1	ATEX Intrinsic Safety ia; Intrinsic Safety ic	★
IA ⁽⁸⁾	ATEX FISCO Intrinsic Safety	★
N1	ATEX Type n	★

Table 1. Rosemount 8800D Vortex Flowmeter (continued)

★ The Standard offering represents the most common options. The starred options (★) should be selected for best delivery.

The Expanded offering is subject to additional delivery lead time.

K1	ATEX Flameproof; Intrinsic Safety; Type n	★
E7	IECEX Flameproof	★
I7	IECEX Intrinsic Safety	★
IG ⁽⁸⁾	IECEX FISCO Intrinsic Safety	★
N7	IECEX Type n	★
K7	IECEX Flameproof; Intrinsic Safety; Type n	★
E2	INMETRO Flameproof	★
I2	INMETRO Intrinsic Safety	★
E3	China Flameproof; Dust	★
I3	China Intrinsic Safety	★
N3	China Type n	★
IH ⁽⁸⁾	China FISCO/FNICO Intrinsic Safety	★
K3	China Flameproof; Dust; Intrinsic Safety; Type n	★
E4 ⁽⁹⁾	TIIS Flameproof	★
IB ⁽⁸⁾	INMETRO FISCO Intrinsic Safety	★
PlantWeb[®] control functionality		
A01 ⁽¹⁰⁾	Basic Control: One Proportional/Integral/Derivative (PID) Function Block	★
Conduit electrical connector		
GE ⁽¹¹⁾	M12, 4-pin, Male Connector (eurofast [®])	
GM ⁽¹¹⁾	A size Mini, 4-pin, Male Connector (minifast [®])	
GN	ATEX Flameproof A size, Mini 4-pin male connector (minifast)	
HART Communication		
HR5	HART 5	★
HR7	HART 7	★
Process diagnostics		
DS3	SMART Fluid Diagnostic	★
Other options		
C4 ⁽¹²⁾	NAMUR alarm and saturation values, high alarm	★
CN ⁽¹²⁾	NAMUR alarm and saturation values, low alarm	★
V5	External ground screw assembly	★
T1	Transient protection terminal block	★
P2	Cleaning for special services	★
PD	Pressure Equipment Directive (PED, per 97/23/EC)	★
M5	LCD indicator	★
R10	Remote electronics with 10 ft (3,0 m) cable	★
R20	Remote electronics with 20 ft (6,1 m) cable	★

Table 1. Rosemount 8800D Vortex Flowmeter (continued)

★ The Standard offering represents the most common options. The starred options (★) should be selected for best delivery.

The Expanded offering is subject to additional delivery lead time.

R30	Remote electronics with 30 ft (9,1 m) cable	★
R33	Remote electronics with 33 ft. (10.1m) cable	★
R50	Remote electronics with 50 ft (15.2 m) cable	★
RXX ⁽¹³⁾	Remote electronics with customer-specified cable length (up to 75 ft (23 m) maximum)	
A10	Armored remote electronics with 10 ft (3.0 m) cable	
A20	Armored remote electronics with 20 ft (6.1 m) cable	
A33	Armored remote electronics with 33ft (10.1 m) cable	
A50	Armored remote electronics with 50 ft (15.2 m) cable	
A75	Armored remote electronics with 75ft (22.9 m) cable	
CPA ⁽¹⁴⁾	CriticalProcess Online Sensor	
Certification options		
Q4	Certificate of Calibration - Consistent with ISO 10474 3.1B or EN 10204 3.1	★
Q8	Material traceability certification per ISO 10474 3.1B and EN 10204 3.1	★
Q25	NACE [®] MR0103 Certificate of Compliance	★
Q69 ⁽¹⁵⁾	Inspection certificate weld examination (wafer) per ISO 10474 3.1B and EN 10204 3.1	★
Q70	Inspection certificate weld examination (flanged) per ISO 10474 3.1B and EN 10204 3.1	
Q71	Inspection certification weld examination (flanged) per ISO 10474 3.1B (includes x-rays) and EN 10204 3.1	
Q72	Inspection certification weld examination (flanged) per ISO 10474 3.1B (includes x-rays on film) and EN 10204 3.1	
Q76	Certification of Positive Material Identification	★
Q79	Certification for Combo PQR/WPQ/WPS with Weld Maps	★
QC2	Visual and Dimensional, Quantity, Display and Configuration Inspection with Certificate	
J2	ASME B31.1 General Compliance (carbon steel only)	
J7	ASME B31.1 Boiler External Piping (BEP) Code Stamp (carbon steel only)	
QKH	KHK Documentation Package	
QP	Calibration certification and tamper evident seal	★
SBS	ABS (American Bureau of Shipping)	
SBV	Bureau Veritas	
SDN	Det Norske Veritas	
SLL	Lloyd's Register (LR) Type Approval	

Table 1. Rosemount 8800D Vortex Flowmeter (continued)

★ The Standard offering represents the most common options. The starred options (★) should be selected for best delivery.

The Expanded offering is subject to additional delivery lead time.

Quick Start Guide (QSG) language options (default is English)		
YA	Danish	★
YB	Hungarian	★
YC	Czech	★
YD	Dutch	★
YF	French	★
YG	German	★
YH	Finnish	★
YI	Italian	★
YJ	Japanese	★
YM	Chinese (Mandarin)	★
YN	Norwegian	★
YL	Polish	★
YP	Portuguese	★
YR	Russian	★
YS	Spanish	★
YW	Swedish	★
Typical model number: 8800D F 020 S A1 N 1 D 1 M5		

- Available in Flanged and Dual from 6-in. through 12-in. and Reducer from 8-in. through 12-in. Class 1500 in 6-in. and 8-in. meterbody sizes and class 900 in 10 through 12-in. meterbody sizes.
- Available on flanged and dual style meters from 1/2" - 8" (15-200 mm) and reducer style meters from 1" - 8" (25 - 200 mm). Also available in 10"-12" (250-300 mm) flanged and dual meters along with 12" (300 mm) reducers when using Super Duplex material of construction.
- Only available for flange and dual style meters from 1-in. through 8-in. (25-200 mm).
- Not available with 1/2-in. line size.
- W1, W4, W8, and W9 are only available with Meter Style F.
- No TIIS approval
- Available with Rosemount 8800DF from 1 1/2-in. (40 mm) through 12-in. (300 mm). Available with 8800DR from 2-in. (50 mm) through 12-in. (300 mm). Not available with 8800DW or 8800DD.
- Fieldbus Intrinsic Safe Concept (FISCO) available with output code F (FOUNDATION Fieldbus digital signal) only.
- TIIS Flameproof Approval requires G1/2 conduit entry.
- Requires output code F.
- Not available with certain hazardous location certifications. Contact a Rosemount representative for details.
- NAMUR compliant operation and the alarm latch options are pre-set at the factory and can be changed to standard operation in the field.
- XX is a customer specified length in feet.
- The CPA option is not available on wafer, 1/2-in. flange, or 1-in. reducer units. In addition it is not available on 1-in. flanged and 1 1/2-in. reducer JIS 10K, EN PN40, or EN PN16. Not available with Super Duplex or B31.1 line sizes greater than 6".
- Q69 available for all Nickel Alloy wafers and stainless steel wafers in line sizes 1/2-in. (15 mm), 6-in. (150 mm), and 8-in. (200 mm).

Table 2. Method of Construction for the 8800DF/8800DD in Nickel Alloy

Line size	A1	A3	A6	A7	K1	K3	K4	K6	K7
½ (15)	C	C	C	W	W	W	NA	W	W
1 (25)	C	C	C	W	W	W	NA	W	W
1½ (40)	C	C	C	W	W	W	NA	W	W
2 (50)	C	C	C	W	C	C	W	W	W
3 (80)	C	C	C	W	C	C	W	W	W
4 (100)	C	C	C	W	C	C	W	W	W
6 (150)	C	C	C	CF	W	W	W	W	CF
8 (200)	C	C	C	CF	W	W	W	W	CF
10 (250)	W	W	W	NA	W	W	W	W	NA
12 (300)	W	W	W	NA	W	W	W	W	NA
C = Nickel Alloy collar and 316 SST lap flange. If weld neck flange is required, V0022 can be ordered.									
W = Nickel Alloy weld neck flange.									
CF = Consult Factory									
NA = Not Available									
All 8800DR Reducer Vortex Meters with Nickel Alloy materials of construction use weld neck flanges.									
Flange codes other than those listed in Table 2 all use weld neck flanges.									

Specifications

Functional specifications

Process fluids

Liquid, gas, and steam applications. Fluids must be homogeneous and single-phase.

Line sizes

Wafer

1/2, 1, 1 1/2, 2, 3, 4, 6, and 8 inches
(DN 15, 25, 40, 50, 80, 100, 150, and 200)

Flanged and dual-sensor style

1/2, 1, 1 1/2, 2, 3, 4, 6, 8, 10, and 12 inches
(DN 15, 25, 40, 50, 80, 100, 150, 200, 250, and 300)

Reducer

1, 1 1/2, 2, 3, 4, 6, 8, 10, and 12 inches
(DN 25, 40, 50, 80, 100, 150, 200, 250, and 300)

Pipe schedules

Process piping Schedules 10, 40, 80, and 160.

Note

The appropriate bore diameter of the process piping must be entered using the Field Communicator or AMS[®] Device Manager. Meters will be shipped from the factory at the Schedule 40 default value unless otherwise specified.

Measurable flow rates

Capable of processing signals from flow applications which meet the sizing requirements below.

To determine the appropriate flowmeter size for an application, process conditions must be within the Reynolds number and velocity limitations for the desired line size provided in [Table 3](#), [Table 4](#), and [Table 5](#).

Note

Consult your local sales representative to obtain a computer sizing program that describes in greater detail how to specify the correct flowmeter size for an application.

The Reynolds number equation shown below combines the effects of density (ρ), viscosity (μ_{cp}), pipe inside diameter (D), and flow velocity (V).

$$R_D = \frac{VD\rho}{\mu_{cp}}$$

Table 3. Minimum Measurable Meter Reynolds Numbers

Meter sizes (Inches/DN)	Reynolds number limitations
1/2 through 4/15 through 100	5000 minimum
6 through 12/150 through 300	

Table 4. Minimum Measurable Meter Velocities⁽¹⁾

	Feet per second	Meters per second
Liquids ⁽²⁾	$\sqrt{36/\rho}$	$\sqrt{54/\rho}$
Gases ⁽²⁾	$\sqrt{36/\rho}$	$\sqrt{54/\rho}$

The ρ is the process fluid density at flowing conditions in lb/ft³ for ft/s and kg/m³ for m/s.

1. Velocities are referenced to schedule 40 pipe.
2. This minimum measurable meter velocity is based on default filter settings.

Table 5. Maximum Measurable Meter Velocities⁽¹⁾ (use the smaller of the two values)

	Feet per second	Meters per second
Liquids	$\sqrt{90,000/\rho}$ or 25	$\sqrt{134,000/\rho}$ or 7.6
Gases ⁽²⁾	$\sqrt{90,000/\rho}$ or 300	$\sqrt{134,000/\rho}$ or 91.4

The ρ is the process fluid density at flowing conditions in lb/ft³ for ft/s and kg/m³ for m/s.

1. Velocities are referenced to schedule 40 pipe.
2. Accuracy limitations for gas and steam for Dual-style meters (1/2-in. to 4-in.): max velocity of 100 ft/s (30.5 m/s).

Process temperature limits**Standard**

–40 to 450 °F (–40 to 232 °C)

Extended

–330 to 800 °F (–200 to 427 °C)

Severe

–330 to 800 °F (–200 to 427 °C)

- The meter body and sensor, in remote mount configurations, is functionally rated to 842 °F process temperature. Process temperature may be further restricted depending on hazardous area options and PED certificates. Consult applicable certificates for particular installation limits.
- 157 °F to 800 °F (–105 to 427 °C) for European Pressure Equipment Directive (PED), consult factory for lower temperature requirements.
- The Super Duplex material of construction is limited to use in applications with process temperatures from –40 to 450 °F (–40 to 232 °C).

Multivariable (MTA option)

–40 to 800 °F (–40 to 427 °C)

- Use above 450 °F (232 °C) requires Extended Sensor

Output signals**4–20 mA Digital HART signal**

Superimposed on 4–20 mA signal

Optional scalable pulse output

0 to 10000 Hz; transistor switch closure with adjustable scaling via HART communications; capable of switching up to 30 Vdc, 120 mA maximum

Digital FOUNDATION Fieldbus signal

Completely digital output with FOUNDATION Fieldbus communication (ITK 6.0 compliant).

Analog output adjustment

Engineering units and lower and upper range values are user-selected. Output is automatically scaled to provide 4 mA at the selected lower range value, 20 mA at the selected upper range value. No frequency input is required to adjust the range values.

Scalable frequency adjustment

The scalable pulse output can be set to a specific velocity, volume, or mass (i.e. 1 pulse = 1 lb). The scalable pulse output can also be scaled to a specific rate of volume, mass, or velocity (i.e. 100 Hz = 500 lb/hr).

Ambient temperature limits**Operating**

–58 to 185 °F (–50 to 85 °C)

–4 to 185 °F (–20 to 85 °C) for flowmeters with local indicator

Storage

–58 to 185 °F (–50 to 85 °C)

–50 to 185 °F (–46 to 85 °C) for flowmeters with local indicator

Pressure limits**Flange style meter**

Rated for ASME B16.5 Class 150, 300, 600, 900, and 1500, EN 1092-1 PN 10, 16, 25, 40, 63, 100, and 160, and JIS 10K, 20K, and 40K

Reducer style meter

Rated for ASME B16.5 Class 150, 300, 600, and 900, EN 1092-1 PN 10, 16, 25, 40, 63, 100, and 160.

Dual sensor style meter

Rated for ASME B16.5 Class 150, 300, 600, 900, and 1500, EN 1092-1 PN 10, 16, 25, 40, 63, 100, and 160, and JIS 10K, 20K, and 40K

Wafer style meter

Rated for ASME B16.5 Class 150, 300, and 600, EN 1092-1 PN 10, 16, 25, 40, 63, and 100, and JIS 10K, 20K, and 40K

Note

All wafer style meters are pressure rated and labeled at 1500 PSI/10.34 MPa at 100 °F/38 °C regardless of alignment ring size code ordered.

Weld-end style meter

W1 Welds to Schedule 10 mating pipe

- 1-4 inch line size 720 psig (4.96 MPa-g)

W4 Welds to Schedule 40 mating pipe

- 1-4 inch line size 1440 psig (9.93 MPa-g)

- 6-12 inch line size 720 psig (4.96 MPa-g)

W8 Welds to Schedule 80 mating pipe

- 1-4 inch line size 2160 psig (14.9 MPa-g)

- 6-12 inch line size 1440 psig (9.93 MPa-g)

W9 Welds to Schedule 160 mating pipe

- 1-4 inch line size 3600 psig (24.8 MPa-g)

- 6-12 inch line size 2160 psig (14.9 MPa-g)

Note

1-in. (25 mm), and 1.5-in. (40 mm) weld to Schedule 80 mating pipe.

Power supply**HART analog**

External power supply required. Flowmeter operates on 10.8 to 42 Vdc terminal voltage (with 250-ohm minimum load required for HART communications, 16.8 Vdc power supply is required)

FOUNDATION Fieldbus

External power supply required. Flowmeter operates on 9 to 32 Vdc, 18 mA maximum.

Power consumption

One watt maximum

Load limitations (HART analog)

Maximum loop resistance is determined by the voltage level of the external power supply, as described by:

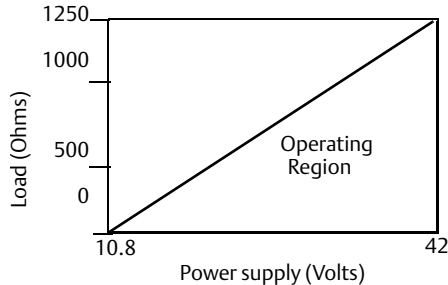

$R_{max} = 41.7(V_{ps} - 10.8)$
 $V_{ps} =$ Power Supply Voltage (Volts)
 $R_{max} =$ Maximum Loop Resistance (Ohms)

Note

HART Communication requires a minimum loop resistance of 250 ohms.

Optional LCD indicator

The optional LCD indicator is capable of displaying:

HART	FOUNDATION Fieldbus
Primary Variable	Primary Variable
Velocity Flow	Percent of Range
Volumetric Flow	Shedding Frequency
Corrected Volumetric Flow (HR5 or HR7 only)	Electronics Temperature (MTA only)
Mass Flow	Process Temperature (MTA only)
Signal Strength (HR5 or HR7 only)	Calculated Process Density (MTA only)
Percent of Range	Integrator Output
Analog Output	Totalizer
Totalizer	
Shedding Frequency	
Pulse Output Frequency	
Electronics Temperature	
Process Temperature (MTA only)	
Calculated Process Density (MTA only)	

If more than one item is selected, the display will scroll through all items selected.

Enclosure rating

FM Type 4X; CSA Type 4X; IP66

Permanent pressure loss

The approximate permanent pressure loss (PPL) from the Rosemount 8800D Flowmeter is calculated for each application in the Vortex sizing software available from your local Rosemount representative.

The PPL is determined using the equation:

$$PPL = \frac{A \times \rho_f \times Q^2}{D^4}$$

where:

- PPL = Permanent Pressure loss (psi or kPa)
- Where:
- ρ_f = Density at operating conditions (lb/ft³ or kg/m³)
- Q = Actual volumetric flow rate (Gas = ft³/min or m³/hr; Liquid = gal/min or l/min)
- D = Flowmeter bore diameter (in. or mm)
- A = Constant depending on meter style, fluid type and flow units. Determined per following table:

Table 6. Determining the PPL

Meter style	English units		SI units	
	A _{Liquid}	A _{Gas}	A _{Liquid}	A _{Gas}
8800DF/W	3.43 10 ⁻⁵	1.93 10 ⁻³	0.425	118
8800DR	3.91 10 ⁻⁵	2.19 10 ⁻³	0.489	136
8800DD ⁽¹⁾	6.12 10 ⁻⁵	3.42 10 ⁻³	0.765	212

1. For all 6- through 12-in. line sizes A is the same for 8800DD and 8800DF

Minimum downstream pressure (liquids)

Flow metering conditions that would allow cavitation, the release of vapor from a liquid, should be avoided. This flow condition can be avoided by remaining within the proper flow range of the meter and by following appropriate system design.

For some liquid applications, incorporation of a back pressure valve should be considered. To prevent cavitation, the minimum downstream pressure should be:

$P = 2.9 * \Delta P + 1.3 * p_v$ or $P = 2.9 * \Delta P + p_v + 0.5$ psia (3.45 kPa)
 (use the smaller of the two results)

P = Line pressure five pipe diameters downstream of the meter (psia or kPa abs)

ΔP = Pressure loss across the meter (psi or kPa)

p_v = Liquid vapor pressure at operating conditions (psia or kPa abs)

Failure mode alarm

HART analog

If self-diagnostics detect a gross flowmeter failure, the analog signal will be driven to the values below:

Low	3.75
High	21.75
NAMUR Low	3.60
NAMUR High	22.6

High or low alarm signal is user-selectable through the fail mode alarm jumper on the electronics. NAMUR-compliant alarm limits are available through the C4 or CN Option. Alarm type is field configurable also.

FOUNDATION Fieldbus

The AI block allows the user to configure the alarm to HI-HI, HI, LO, or LO-LO with a variety of priority levels.

Saturation output values

When the operating flow is outside the range points, the analog output continues to track the operating flow until reaching the saturation value listed below; the output does not exceed the listed saturation value regardless of the operating flow. The NAMUR-Compliant Saturation Values are available through the C4 or CN option. Saturation type is field configurable.

Alarm	mA output
Low	3.9
High	20.8
NAMUR Low	3.8
NAMUR High	20.5

Damping

Flow Damping adjustable between 0.2 and 255 seconds.

Process temperature damping adjustable between 0.4 and 32.0 seconds (MTA Option only).

Response time

Three vortex shedding cycles or 300 ms, whichever is greater, maximum required to reach 63.2% of actual input with the minimum damping (0.2 seconds).

Turn-on time

HART analog

Less than six seconds plus the response time to rated accuracy from power up (less than eight seconds with the MTA Option).

FOUNDATION Fieldbus

Performance within specifications no greater than 10.0 seconds after power is applied.

Transient protection

The optional transient terminal block prevents damage to the flowmeter from transients induced by lightning, welding, heavy electrical equipment, or switch gears. The transient protection electronics are located in the terminal block.

The transient terminal block meets the following specifications:

- IEEE C62.41 - 2002 Category B
- 3 kA crest (8 3 20 μs)
- 6 kV crest (1.2 3 50 μs)
- 6 kV/0.5 kA (0.5 μs, 100 kHz, ring wave)

Security lockout

When the security lockout jumper is enabled, the electronics will not allow you to modify parameters that affect flowmeter output.

Output testing

Current source

Flowmeter may be commanded to set the current to a specified value between 4 and 20 mA.

Frequency source

Flowmeter may be commanded to set the frequency to a specified value between 0 and 10000 Hz.

Low flow cutoff

Adjustable over entire flow range. Below selected value, output is driven to 4 mA and zero pulse output frequency.

Humidity limits

Operates in 0–95% relative humidity under noncondensing conditions (tested to IEC 60770, Section 6.2.11).

Overrange capability

HART analog

Analog signal output continues to 105 percent of span, then remains constant with increasing flow. The digital and pulse outputs will continue to indicate flow up to the upper sensor limit of the flowmeter and a maximum pulse output frequency of 10400 Hz.

FOUNDATION Fieldbus

For liquid process fluid type, the transducer block digital output will continue to a nominal value of 25 ft/s. After that, the status associated with the transducer block output will go to UNCERTAIN. Above a nominal value of 30 ft/s, the status will go to BAD.

For gas/steam service, the transducer block digital output will continue to a nominal value of 220 ft/s for 0.5 and 1.0-in. line sizes and a nominal value of 250 ft/s for 1.5–12-in. line sizes. After that, the status associated with the transducer block output will go to UNCERTAIN. Above a nominal value of 300 ft/s for all line sizes, the status will go to BAD.

Flow calibration

Meter bodies are flow-calibrated and assigned a unique calibration factor (K-factor) at the factory. The calibration factor is entered into the electronics, enabling interchangeability of electronics and/or sensors without calculations or compromise in accuracy of the calibrated meter body.

Status (FOUNDATION Fieldbus only)

If self-diagnostics detect a transmitter failure, the status of the measurement will inform the control system. Status may also set the PID output to a safe value.

Schedule entries (FOUNDATION Fieldbus only)

Six (6)

Links (FOUNDATION Fieldbus only)

Twelve (12)

**Virtual communications relationships (VCRs)
(FOUNDATION Fieldbus only)**

Maximum VCRs: 20

Number of Permanent Entries: 1

Table 7. Block Information

Block	Base index	Execution time (milliseconds)
Resource (RB)	1000	N/A
Transducer (TB)	1200	N/A
Analog Input 1 (AI 1)	1400	15
Analog Input 2 (AI 2)	1600	15
Proportional/ Integral/Derivative (PID)	1800	20
Integrator (INTEG)	2000	25
Arithmetic (ARITH)	2200	20
Analog Input 3 (AI 3)	2400	15
Analog Input 4 (AI 4)	2600	15
Analog Input 5 (AI 5)	2800	15

Typical Flow Ranges

Table 8 - Table 19 show typical flow ranges for some common process fluids with default filter settings. Consult your local sales representative to obtain a computer sizing program that describes in greater detail the flow range for an application.

Table 8. Typical Pipe Velocity Ranges for 8800D and 8800DR⁽¹⁾

Process line size (inches/ DN)	Vortex meter ⁽²⁾	Liquid velocity ranges		Gas velocity ranges	
		(ft/s)	(m/s)	(ft/s)	(m/s)
0.5/ 15	8800DF005	0.70 to 25.0	0.21 to 7.6	6.50 to 250.0	1.98 to 76.2
1/ 25	8800DF010	0.70 to 25.0	0.21 to 7.6	6.50 to 250.0	1.98 to 76.2
	8800DR010	0.25 to 8.8	0.08 to 2.7	2.29 to 87.9	0.70 to 26.8
1.5/ 40	8800DF015	0.70 to 25.0	0.21 to 7.6	6.50 to 250.0	1.98 to 76.2
	8800DR015	0.30 to 10.6	0.09 to 3.2	2.76 to 106.1	0.84 to 32.3
2/ 50	8800DF020	0.70 to 25.0	0.21 to 7.6	6.50 to 250.0	1.98 to 76.2
	8800DR020	0.42 to 15.2	0.13 to 4.6	3.94 to 151.7	1.20 to 46.2
3/ 80	8800DF030	0.70 to 25.0	0.21 to 7.6	6.50 to 250.0	1.98 to 76.2
	8800DR030	0.32 to 11.3	0.10 to 3.5	2.95 to 113.5	0.90 to 34.6
4/ 100	8800DF040	0.70 to 25.0	0.21 to 7.6	6.50 to 250.0	1.98 to 76.2
	8800DR040	0.41 to 14.5	0.12 to 4.4	3.77 to 145.2	1.15 to 44.3
6/ 150	8800DF060	0.70 to 25.0	0.21 to 7.6	6.50 to 250.0	1.98 to 76.2
	8800DR060	0.31 to 11.0	0.09 to 3.4	2.86 to 110.2	0.87 to 33.6
8/ 200	8800DF080	0.70 to 25.0	0.21 to 7.6	6.50 to 250.0	1.98 to 76.2
	8800DR080	0.40 to 14.4	0.12 to 4.4	3.75 to 144.4	1.14 to 44.0
10/ 250	8800DF100	0.90 to 25.0	0.27 to 7.6	6.50 to 250.0	1.98 to 76.2
	8800DR100	0.44 to 15.9	0.13 to 4.8	4.12 to 158.6	1.26 to 48.3
12/ 300	8800DF120	1.10 to 25.0	0.34 to 7.6	6.50 to 250.0	1.98 to 76.2
	8800DR120	0.63 to 17.6	0.19 to 5.4	4.58 to 176.1	1.40 to 53.7

1. Table 8 is a reference of pipe velocities that can be measured for the standard Rosemount 8800D and the reducer Rosemount 8800DR Vortex Meters. It does not consider density limitations, as described in tables 2 and 3. Velocities are referenced in schedule 40 pipe.
2. Velocity range of the Rosemount 8800DW is the same as Rosemount 8800DF.

Table 9. Water Flow Rate Limits for the Rosemount 8800D and 8800DR⁽¹⁾

Process line size (inches/ DN)	Vortex meter ⁽²⁾	Minimum and maximum measurable water flow rates ⁽³⁾	
		Gallons/minute	Cubic meters/hour
0.5/ 15	8800DF005	1.76 to 23.7	0.40 to 5.4
1/ 25	8800DF010	2.96 to 67.3	0.67 to 15.3
1.5/ 40	8800DR010	1.76 to 23.7	0.40 to 5.4
	8800DF015	4.83 to 158	1.10 to 35.9
2/ 50	8800DR015	2.96 to 67.3	0.67 to 15.3
	8800DF020	7.96 to 261	1.81 to 59.4
3/ 80	8800DR020	4.83 to 158.0	1.10 to 35.9
	8800DF030	17.5 to 576	4.00 to 130
4/ 100	8800DR030	7.96 to 261.0	1.81 to 59.3
	8800DF040	30.2 to 992	6.86 to 225
6/ 150	8800DR040	17.5 to 576	4.00 to 130
	8800DF060	68.5 to 2251	15.6 to 511
8/ 200	8800DR060	30.2 to 992	6.86 to 225
	8800DF080	119 to 3898	27.0 to 885
10/ 250	8800DR080	68.5 to 2251	15.6 to 511
	8800DF100	231 to 6144	52.2 to 1395
12/ 300	8800DR100	119 to 3898	27.0 to 885
	8800DF120	391 to 8813	88.8 to 2002
	8800DR120	231 to 6144	52.2 to 1395

1. Table 9 is a reference of flow rates that can be measured for the standard Rosemount 8800D and the reducer 8800DR Vortex Meters. It does not consider density limitations, as described in tables 2 and 3.
2. Velocity range of the 8800DW is the same as 8800DF.
3. Conditions: 77 °F (25 °C) and 14.7 psia (1.01 bar absolute)

Table 10. Air Flow Rate Limits at 59 °F (15 °C)

Process pressure	Flow rate limits	Minimum and maximum air flow rates for line sizes 1/2-in./DN 15 through 1-in./DN 25							
		1/2-in./DN 15				1-in./DN 25			
		Rosemount 8800D		Rosemount 8800DR		Rosemount 8800D		Rosemount 8800DR	
		ACFM	ACMH	ACFM	ACMH	ACFM	ACMH	ACFM	ACMH
0 psig (0 bar G)	max	27.9	47.3	Not Available	Not Available	79.2	134	27.9	47.3
	min	4.62	7.84	Available	Available	9.71	16.5	4.62	7.84
50 psig (3,45 bar G)	max	27.9	47.3	Not Available	Not Available	79.2	134	27.9	47.3
	min	1.31	2.22	Available	Available	3.72	6.32	1.31	2.22
100 psig (6,89 bar G)	max	27.9	47.3	Not Available	Not Available	79.2	134	27.9	47.3
	min	0.98	1.66	Available	Available	2.80	4.75	0.98	1.66
150 psig (10,3 bar G)	max	27.9	47.3	Not Available	Not Available	79.2	134	27.9	47.3
	min	0.82	1.41	Available	Available	2.34	3.98	0.82	1.41
200 psig (13,8 bar G)	max	27.9	47.3	Not Available	Not Available	79.2	134	27.9	47.3
	min	0.82	1.41	Available	Available	2.34	3.98	0.82	1.41
300 psig (20,7 bar G)	max	27.9	47.3	Not Available	Not Available	79.2	134	27.9	47.3
	min	0.82	1.41	Available	Available	2.34	3.98	0.82	1.41
400 psig (27,6 bar G)	max	25.7	43.9	Not Available	Not Available	73.0	124	25.7	43.9
	min	0.82	1.41	Available	Available	2.34	3.98	0.82	1.41
500 psig (34,5 bar G)	max	23.0	39.4	Not Available	Not Available	66.0	112	23.0	39.4
	min	0.82	1.41	Available	Available	2.34	3.98	0.82	1.41

Table 11. Air Flow Rate Limits at 59 °F (15 °C)

Process pressure	Flow rate limits	Minimum and maximum air Flow rates for line sizes 1 1/2-in./DN 40 through 2-in./DN 50							
		1 1/2-in./DN 40				2-in./DN 50			
		Rosemount 8800D		Rosemount 8800DR		Rosemount 8800D		Rosemount 8800DR	
		ACFM	ACMH	ACFM	ACMH	ACFM	ACMH	ACFM	ACMH
0 psig (0 bar G)	max min	212 18.4	360 31.2	79.2 9.71	134 16.5	349 30.3	593 51.5	212 18.4	360 31.2
50 psig (3,45 bar G)	max min	212 8.76	360 14.9	79.2 3.72	134 6.32	349 14.5	593 24.6	212 8.76	360 14.9
100 psig (6,89 bar G)	max min	212 6.58	360 11.2	79.2 2.80	134 4.75	349 10.8	593 18.3	212 6.58	360 11.2
150 psig (10,3 bar G)	max min	212 5.51	360 9.36	79.2 2.34	134 3.98	349 9.09	593 15.4	212 5.51	360 9.36
200 psig (13,8 bar G)	max min	212 5.51	360 9.36	79.2 2.34	134 3.98	349 9.09	593 15.4	212 5.51	360 9.36
300 psig (20,7 bar G)	max min	198 5.51	337 9.36	79.2 2.34	134 3.98	326 9.09	554 15.4	198 5.51	337 9.36
400 psig (27,6 bar G)	max min	172 5.51	293 9.36	73.0 2.34	124 3.98	284 9.09	483 15.4	172 5.51	293 9.36
500 psig (34,5 bar G)	max min	154 5.51	262 9.36	66.0 2.34	112 3.98	254 9.09	432 15.4	154 5.51	262 9.36

Table 12. Air Flow Rate Limits at 59 °F (15 °C)

Process pressure	Flow rate limits	Minimum and maximum air flow rates for line sizes 3-in./DN 80 through 4-in./DN 100							
		3-in./DN 80				4-in./DN 100			
		Rosemount 8800D		Rosemount 8800DR		Rosemount 8800D		Rosemount 8800DR	
		ACFM	ACMH	ACFM	ACMH	ACFM	ACMH	ACFM	ACMH
0 psig (0 bar G)	max min	770 66.8	1308 114	349 30.3	593 51.5	1326 115	2253 195	770 66.8	1308 114
50 psig (3,45 bar G)	max min	770 31.8	1308 54.1	349 14.5	593 24.6	1326 54.8	2253 93.2	770 31.8	1308 54.1
100 psig (6,89 bar G)	max min	770 23.9	1308 40.6	349 10.8	593 18.3	1326 41.1	2253 69.8	770 23.9	1308 40.6
150 psig (10,3 bar G)	max min	770 20.0	1308 34.0	349 9.09	593 15.4	1326 34.5	2253 58.6	770 20.0	1308 34.0
200 psig (13,8 bar G)	max min	770 20.0	1308 34.0	349 9.09	593 15.4	1326 34.5	2253 58.6	770 20.0	1308 34.0
300 psig (20,7 bar G)	max min	718 20.0	1220 34.0	326 9.09	554 15.4	1237 34.5	2102 58.6	718 20.0	1220 34.0
400 psig (27,6 bar G)	max min	625 20.0	1062 34.0	284 9.09	483 15.4	1076 34.5	1828 58.6	625 20.0	1062 34.0
500 psig (34,5 bar G)	max min	560 20.0	951 34.0	254 9.09	432 15.4	964 34.5	1638 58.6	560 20.0	951 34.0

Table 13. Air Flow Rate Limits at 59 °F (15 °C)

Process pressure	Flow rate limits	Minimum and maximum air flow rates for line sizes 6-in./DN 150 through 8-in./DN 200							
		6-in./DN 150				8-in./DN 200			
		Rosemount 8800D		Rosemount 8800DR		Rosemount 8800D		Rosemount 8800DR	
		ACFM	ACMH	ACFM	ACMH	ACFM	ACMH	ACFM	ACMH
0 psig (0 bar G)	max	3009	5112	1326	2253	5211	8853	3009	5112
	min	261	443	115	195	452	768	261	443
50 psig (3,45 bar G)	max	3009	5112	1326	2253	5211	8853	3009	5112
	min	124	211	54.8	93.2	215	365	124	211
100 psig (6,89 bar G)	max	3009	5112	1326	2253	5211	8853	3009	5112
	min	93.3	159	41.1	69.8	162	276	93.3	159
150 psig (10,3 bar G)	max	3009	5112	1326	2253	5211	8853	3009	5112
	min	78.2	133	34.5	58.6	135	229	78.2	133
200 psig (13,8 bar G)	max	3009	5112	1326	2253	5211	8853	3009	5112
	min	78.2	133	34.5	58.6	135	229	78.2	133
300 psig (20,7 bar G)	max	2807	4769	1237	2102	4862	8260	2807	4769
	min	78.2	133	34.5	58.6	135	229	78.2	133
400 psig (27,6 bar G)	max	2442	4149	1076	1828	4228	7183	2442	4149
	min	78.2	133	34.5	58.6	136	229	78.2	133
500 psig (34,5 bar G)	max	2188	3717	964	1638	3789	6437	2188	3717
	min	78.2	133	34.5	58.6	136	229	78.2	133

Table 14. Saturated Steam Flow Rate Limits (assumes steam quality is 100%)

Process pressure	Flow rate limits	Minimum and maximum saturated steam flow rates for line sizes 1/2-in./DN 15 through 1-in./DN 25							
		1/2-in./DN 15				1-in./DN 25			
		Rosemount 8800D		Rosemount 8800DR		Rosemount 8800D		Rosemount 8800DR	
		lb/hr	kg/hr	lb/hr	kg/hr	lb/hr	kg/hr	lb/hr	kg/hr
15 psig (1,03 bar G)	max	120	54.6	Not Available	Not Available	342	155	120	54.6
	min	12.8	5.81	Available	Available	34.8	15.8	12.8	5.81
25 psig (1,72 bar G)	max	158	71.7	Not Available	Not Available	449	203	158	71.7
	min	14.0	6.35	Available	Available	39.9	18.1	14.0	6.35
50 psig (3,45 bar G)	max	250	113	Not Available	Not Available	711	322	250	113
	min	17.6	8.00	Available	Available	50.1	22.7	17.6	8.00
100 psig (6,89 bar G)	max	429	194	Not Available	Not Available	1221	554	429	194
	min	23.1	10.5	Available	Available	65.7	29.8	23.1	10.5
150 psig (10,3 bar G)	max	606	275	Not Available	Not Available	1724	782	606	275
	min	27.4	12.5	Available	Available	78.1	35.4	27.4	12.5
200 psig (13,8 bar G)	max	782	354	Not Available	Not Available	2225	1009	782	354
	min	31.2	14.1	Available	Available	88.7	40.2	31.2	14.1
300 psig (20,7 bar G)	max	1135	515	Not Available	Not Available	3229	1464	1135	515
	min	37.6	17.0	Available	Available	107	48.5	37.6	17.0
400 psig (27,6 bar G)	max	1492	676	Not Available	Not Available	4244	1925	1492	676
	min	44.1	20.0	Available	Available	125	56.7	44.1	20.0
500 psig (34,5 bar G)	max	1855	841	Not Available	Not Available	5277	2393	1855	841
	min	54.8	24.9	Available	Available	156	70.7	54.8	24.9

Note

The Rosemount 8800D measures the volumetric flow under operating conditions (i.e. the actual volume at the operating pressure and temperature–acfm or acmh), as shown above. However, gas volumes are strongly dependent on pressure and temperature. Therefore, gas quantities are typically stated in standard or normal conditions (e.g. SCFM or NCMH). (Standard conditions are typically 59 °F and 14.7 psia. Normal conditions are typically 0 °C and 1.01 bar abs.) The flow rate limits in standard conditions are found using the equations below:

$$\text{Standard Flow Rate} = \text{Actual Flow Rate} \times \text{Density Ratio}$$

$$\text{Density Ratio} = \text{Density at Actual (Operating) Conditions} / \text{Density at Standard Conditions}$$

Table 15. Saturated Steam Flow Rate Limits (assumes steam quality is 100%)

Process pressure	Flow rate limits	Minimum and maximum saturated steam flow rates for line sizes 1/2-in./DN 15 through 1-in./DN 25							
		1/2-in./DN 15				1-in./DN 25			
		Rosemount 8800D		Rosemount 8800DR		Rosemount 8800D		Rosemount 8800DR	
		lb/hr	kg/hr	lb/hr	kg/hr	lb/hr	kg/hr	lb/hr	kg/hr
15 psig (1,03 bar G)	max	120	54.6	Not Available	Not Available	342	155	120	54.6
	min	12.8	5.81	Available	Available	34.8	15.8	12.8	5.81
25 psig (1,72 bar G)	max	158	71.7	Not Available	Not Available	449	203	158	71.7
	min	14.0	6.35	Available	Available	39.9	18.1	14.0	6.35
50 psig (3,45 bar G)	max	250	113	Not Available	Not Available	711	322	250	113
	min	17.6	8.00	Available	Available	50.1	22.7	17.6	8.00
100 psig (6,89 bar G)	max	429	194	Not Available	Not Available	1221	554	429	194
	min	23.1	10.5	Available	Available	65.7	29.8	23.1	10.5
150 psig (10,3 bar G)	max	606	275	Not Available	Not Available	1724	782	606	275
	min	27.4	12.5	Available	Available	78.1	35.4	27.4	12.5
200 psig (13,8 bar G)	max	782	354	Not Available	Not Available	2225	1009	782	354
	min	31.2	14.1	Available	Available	88.7	40.2	31.2	14.1
300 psig (20,7 bar G)	max	1135	515	Not Available	Not Available	3229	1464	1135	515
	min	37.6	17.0	Available	Available	107	48.5	37.6	17.0
400 psig (27,6 bar G)	max	1492	676	Not Available	Not Available	4244	1925	1492	676
	min	44.1	20.0	Available	Available	125	56.7	44.1	20.0
500 psig (34,5 bar G)	max	1855	841	Not Available	Not Available	5277	2393	1855	841
	min	54.8	24.9	Available	Available	156	70.7	54.8	24.9

Table 16. Saturated Steam Flow Rate Limits (assumes steam quality is 100%)

Process pressure	Flow rate limits	Minimum and maximum saturated steam flow rates for line sizes 1 1/2-in./DN 40 through 2-in./DN 50							
		1 1/2-in./DN 40				2-in./DN 50			
		Rosemount 8800D		Rosemount 8800DR		Rosemount 8800D		Rosemount 8800DR	
		lb/hr	kg/hr	lb/hr	kg/hr	lb/hr	kg/hr	lb/hr	kg/hr
15 psig (1,03 bar G)	max	917	416	342	155	1511	685	917	416
	min	82.0	37.2	34.8	15.8	135	61.2	82.0	37.2
25 psig (1,72 bar G)	max	1204	546	449	203	1983	899	1204	546
	min	93.9	42.6	39.9	18.1	155	70.2	93.9	42.6
50 psig (3,45 bar G)	max	1904	864	711	322	3138	1423	1904	864
	min	118	53.4	50.1	22.7	195	88.3	118	53.4
100 psig (6,89 bar G)	max	3270	1483	1221	554	5389	2444	3270	1483
	min	155	70.1	65.7	29.8	255	116	155	70.1
150 psig (10,3 bar G)	max	4616	2094	1724	782	7609	3451	4616	2094
	min	184	83.2	78.1	35.4	303	137	184	83.2
200 psig (13,8 bar G)	max	5956	2702	2225	1009	9818	4453	5956	2702
	min	209	94.5	88.7	40.2	344	156	209	94.5
300 psig (20,7 bar G)	max	8644	3921	3229	1464	14248	6463	8644	3921
	min	252	114	107	48.5	415	189	252	114
400 psig (27,6 bar G)	max	11362	5154	4244	1925	18727	8494	11362	5154
	min	295	134	125	56.7	487	221	295	134
500 psig (34,5 bar G)	max	14126	6407	5277	2393	23284	10561	14126	6407
	min	367	167	156	70.7	605	274	367	167

Table 17. Saturated Steam Flow Rate Limits (assumes steam quality is 100%)

Process pressure	Flow rate limits	Minimum and maximum saturated steam flow rates for line sizes 3-in./DN 80 through 4-in./DN 100							
		3-in./DN 80				4-in./DN 100			
		Rosemount 8800D		Rosemount 8800DR		Rosemount 8800D		Rosemount 8800DR	
		lb/hr	kg/hr	lb/hr	kg/hr	lb/hr	kg/hr	lb/hr	kg/hr
15 psig (1,03 bar G)	max	3330	1510	1511	685	5734	2601	3330	1510
	min	298	135	135	61.2	513	233	298	135
25 psig (1,72 bar G)	max	4370	1982	1983	899	7526	3414	4370	1982
	min	341	155	155	70.2	587	267	341	155
50 psig (3,45 bar G)	max	6914	3136	3138	1423	11905	5400	6914	3136
	min	429	195	195	88.3	739	335	429	195
100 psig (6,89 bar G)	max	11874	5386	5389	2444	20448	9275	11874	5386
	min	562	255	255	116	968	439	562	255
150 psig (10,3 bar G)	max	16763	7603	7609	3451	28866	13093	16763	7603
	min	668	303	303	137	1150	522	668	303
200 psig (13,8 bar G)	max	21630	9811	9818	4453	37247	16895	21630	9811
	min	759	344	344	156	1307	593	759	344
300 psig (20,7 bar G)	max	31389	14237	14248	6463	54052	24517	31389	14237
	min	914	415	415	189	1574	714	914	415
400 psig (27,6 bar G)	max	41258	18714	18727	8494	71047	32226	41258	18714
	min	1073	487	487	221	1847	838	1073	487
500 psig (34,5 bar G)	max	51297	23267	23284	10561	88334	40068	51297	23267
	min	1334	605	605	274	2297	1042	1334	605

Table 18. Saturated Steam Flow Rate Limits (assumes steam quality is 100%)

Process pressure	Flow rate limits	Minimum and maximum saturated steam flow rates for line sizes 6-in./DN 150 through 8-in./DN 200							
		6-in./DN 150				8-in./DN 200			
		Rosemount 8800D		Rosemount 8800DR		Rosemount 8800D		Rosemount 8800DR	
		lb/hr	kg/hr	lb/hr	kg/hr	lb/hr	kg/hr	lb/hr	kg/hr
15 psig (1,03 bar G)	max	13013	5903	5734	2601	22534	10221	13013	5903
	min	1163	528	513	233	2015	914	1163	528
25 psig (1,72 bar G)	max	17080	7747	7526	3414	29575	13415	17080	7747
	min	1333	605	587	267	2308	1047	1333	605
50 psig (3,45 bar G)	max	27019	12255	11905	5400	46787	21222	27019	12255
	min	1676	760	739	335	2903	1317	1676	760
100 psig (6,89 bar G)	max	46405	21049	20448	9275	80356	36449	46405	21049
	min	2197	996	968	439	3804	1725	2197	996
150 psig (10,3 bar G)	max	65611	29761	28866	13093	113440	51455	65611	29761
	min	2610	1184	1150	522	4520	2050	2610	1184
200 psig (13,8 bar G)	max	84530	38342	37247	16895	146375	66395	84530	38342
	min	2965	1345	1307	593	5134	2329	2965	1345
300 psig (20,7 bar G)	max	122666	55640	54052	24517	212411	96348	122666	55640
	min	3572	1620	1574	714	6185	2805	3572	1620
400 psig (27,6 bar G)	max	161236	73135	71047	32226	279200	126643	161236	73135
	min	4192	1901	1847	838	7259	3293	4192	1901
500 psig (34,5 bar G)	max	200468	90931	88334	40068	347134	157457	200468	90931
	min	5212	2364	2297	1042	9025	4094	5212	2364

Table 19. Saturated Steam Flow Rate Limits (assumes steam quality is 100%)

Process pressure	Flow rate limits	Minimum and maximum saturated steam flow rates for line sizes 10-in./DN 250 through 12-in./DN 300							
		10-in./DN 250				12-in./DN 300			
		Rosemount 8800D		Rosemount 8800DR		Rosemount 8800D		Rosemount 8800DR	
		lb/hr	kg/hr	lb/hr	kg/hr	lb/hr	kg/hr	lb/hr	kg/hr
15 psig (1,03 bar G)	max	35519	16111	22534	10221	50994	23130	35519	16111
	min	3175	1440	2015	914	4554	2066	3175	1440
25 psig (1,72 bar G)	max	46618	21146	29575	13415	66862	30328	46618	21146
	min	4570	2073	2308	1047	5218	2367	4570	2073
50 psig (3,45 bar G)	max	73748	33452	46787	21222	105774	47978	73748	33452
	min	4575	2075	2903	1317	6562	2976	4575	2075
100 psig (6,89 bar G)	max	126660	57452	80356	36449	181663	82401	126660	57452
	min	5996	2720	3804	1725	8600	3901	5996	2720
150 psig (10,3 bar G)	max	178808	81106	113440	51455	256457	116327	178808	81106
	min	7125	3232	4520	2050	10218	4635	7125	3232
200 psig (13,8 bar G)	max	230722	104654	146375	66395	330915	150101	230722	104654
	min	8092	3670	5134	2329	11607	5265	8092	3670
300 psig (20,7 bar G)	max	334810	151867	212411	96348	480203	217816	334810	151867
	min	9749	4422	6185	2805	13983	6343	9749	4422
400 psig (27,6 bar G)	max	440085	199619	279200	126643	631195	286305	440085	199619
	min	11442	5190	7259	3293	16411	7444	11442	5190
500 psig (34,5 bar G)	max	547165	248190	347134	157457	784775	355968	547165	248190
	min	14226	6453	9025	4094	20404	9255	14226	6453

Performance specifications

The following performance specifications are for all Rosemount models except where noted. Digital performance specifications applicable to both Digital HART and FOUNDATION Fieldbus output.

Flow accuracy

Includes linearity, hysteresis, and repeatability.

Liquids - for Reynolds numbers over 20000

Digital and pulse output

±0.65% of rate

Note

The accuracy for the 8800DR, line sizes 6- to 12-in. (150 to 300 mm), is ±1.0% of rate.

Analog output

Same as pulse output plus an additional 0.025% of span

Gas and steam - for Reynolds numbers over 15,000

Digital and pulse output

±1.0% of rate

Note: The accuracy for the 8800DR, line sizes 6 to 12-in. (150 mm to 300 mm), is ±1.35% of rate.

Analog output

Same as pulse output plus an additional 0.025% of span

Accuracy limitations for gas and steam:

For 1/2- and 1-in. (DN 15 and DN 25): max velocity of 220 ft/s (67.06 m/s)

For 1/2- to 4-in. (DN 15 to DN 200) Dual-style meters: max velocity of 100 ft/s (30.5 m/s)

Note

As the meter Reynolds Numbers decreases below the stated limit to 10,000 the accuracy error band will increase linearly to +/-2.0%. For Reynolds Numbers down to 5,000 the accuracy error band will increase linearly from +/-2.0% to +/-6.0%.

Process temperature accuracy

2.2 °F (1.2 °C) or 0.4% of reading (in °C), whichever is greater.

Note

For remote mount installations, add ±0.018 °F/ft. (±0.03 °C/m) of uncertainty to the temperature measurement.

Mass flow accuracy for temperature compensated steam mass flow

±2.0% of rate (Typical)

Repeatability

±0.1% of actual flow rate

Mass flow accuracy for temperature compensated liquid mass flow (water)

±0.70% of rate up to 500 °F (260 °C)

±0.85% of rate between 500 and 600 °F (260 and 316 °C)

Repeatability

±0.1% of actual flow rate

Mass flow accuracy for temperature compensated liquid mass flow (user-defined)

Dependent on user inputs

Repeatability

±0.1% of actual flow rate

Stability

±0.1% of rate over one year

Process temperature effect

Automatic K-factor correction with user-entered process temperature.

Table 20 indicates the percent change in K-factor per 100 °F (55.6 °C) in process temperature from reference temperature of 77 °F (25 °C).

Table 20. Process Temperature Effect

Material	Percent change in K-factor per 100 °F (55.6 °C)
316L @ < 77 °F (25 °C)	+ 0.23
316L @ > 77 °F (25 °C)	- 0.27
Nickel Alloy C < 77 °F (25 °C)	+ 0.22
Nickel Alloy C > 77 °F (25 °C)	- 0.22

Ambient temperature effect

Digital and pulse outputs

No effect

Analog output

±0.1% of span from -58 to 185 °F (-50 to 85 °C)

Vibration effect

An output with no process flow may be detected if sufficiently high vibration is present.

The meter design will minimize this effect, and the factory settings for signal processing are selected to eliminate these errors for most applications.

If an output error at zero flow is still detected, it can be eliminated by adjusting the low flow cutoff, trigger level, or low-pass filter.

As the process begins to flow through the meter, most vibration effects are quickly overcome by the flow signal.

Vibration specifications

Integral aluminum housings, remote aluminum housings, and remote SST housings

At or near the minimum liquid flow rate in a normal pipe mounted installation, the maximum vibration should be 0.087-in. (2,21 mm) double amplitude displacement or 1 g acceleration, whichever is smaller. At or near the minimum gas flow rate in a normal pipe mounted installation, the maximum vibration should be 0.043-in. (1,09 mm) double amplitude displacement or $1/2$ g acceleration, whichever is smaller.

Integral SST housing

At or near the minimum liquid flow rate in a normal pipe mounted installation, the maximum vibration should be 0.044-in. (1,11 mm) double amplitude displacement or $1/3$ g acceleration, whichever is smaller. At or near the minimum gas flow rate in a normal pipe mounted installation, the maximum vibration should be 0.022-in. (0,55 mm) double amplitude displacement or $1/6$ g acceleration, whichever is smaller.

Mounting position effect

Meter will meet accuracy specifications when mounted in horizontal, vertical, or inclined pipelines. Best practice for mounting in a horizontal pipe is to orient the shedder bar in the horizontal plane. This will prevent solids in liquid applications and liquid in gas/steam applications from disrupting the shedding frequency.

EMI/RFI effect

Meets EMC requirements to EU Directive 2004/108/EC.

HART analog

Output error less than $\pm 0.025\%$ of span with twisted pair from 80-1000 MHz for radiated field strength of 10 V/m; 1.4 - 2.0 GHz for radiated field strength of 3 V/m; 2.0 - 2.7 GHz for radiated field strength of 1 V/m. Tested per EN61326.

FOUNDATION Fieldbus and digital HART

No effect on the values that are being given if using HART digital signal or FOUNDATION Fieldbus. Tested per EN 61326.

Magnetic-field interference

HART analog

Output error less than $\pm 0.025\%$ of span at 30 A/m (rms). Tested per EN 61326.

FOUNDATION Fieldbus

No effect on digital output accuracy at 30 A/m (rms). Tested per EN 61326.

Series mode noise rejection

HART analog

Output error less than $\pm 0.025\%$ of span at 1 V rms, 60 Hz.

FOUNDATION Fieldbus

No effect on digital output accuracy at 1 V rms, 60 Hz.

Common mode noise rejection

HART analog

Output error less than $\pm 0.025\%$ of span at 30 V rms, 60 Hz.

FOUNDATION Fieldbus

No effect on digital output accuracy at 250 V rms, 60 Hz.

Power supply effect

HART analog

Less than 0.005% of span per volt

FOUNDATION Fieldbus

No effect on accuracy.

Physical specifications

NACE compliance

Materials of Construction meet NACE material recommendations per MR0175/ISO15156 for use in H₂S containing environments in oil field production. Materials of construction also meet NACE recommendations per MR0103-2003 for corrosive petroleum refining environments. MR0103 compliance requires Q25 option in model code.

Note

Certificate of compliance for MR0175/ISO15156 requires Q15 as a separate line item.

Electrical connections

1/2–14 or M20 3 1.5 conduit threads; screw terminals provided for 4–20 mA, FOUNDATION Fieldbus, and pulse output connections; communicator connections permanently fixed to terminal block.

Non-wetted materials

Housing

Low-copper aluminum (FM Type 4X, CSA Type 4X, IP66)
Optional SST housing

Paint

Polyurethane

Cover O-rings

Buna-N

Flanges

316/316L lap joint

Temperature sensor (MTA option)

Type-N Thermocouple

Process-wetted materials

Meter body

CF-3M cast stainless, N06022 wrought Nickel Alloy and CW2M cast Nickel Alloy. Also available in WCB and LCC cast carbon steel and 6A duplex stainless steel.

Flanges

316/316L stainless steel
Nickel Alloy N06022 Weld Neck
A105 forged carbon steel
LF2 forged carbon steel
UNS S32760 wrought duplex stainless steel

Collars

Nickel Alloy N06022
316/316L Stainless Steel

Surface finish of flanges and collars

Standard: To the requirements of the applicable flange standard.
Smooth: 63 to 125 μ inches
(1.6 to 3.1 μ meters) Ra roughness

Process connections

Mounts between the following flange configurations:

ASME B16.5: Class 150, 300, 600, 900, 1500

EN 1092-1: PN 10, 16, 25, 40, 64, 100, 160

JIS B2220: 10K, 20K, and 40K

Weld-end: Schedule 10, Schedule 40, Schedule 80, Schedule 160

Mounting

Integral (standard)

Electronics are mounted on meter body.

Remote (optional)

Electronics may be mounted remote from the meter body. Interconnecting coaxial cable available in nonadjustable 10, 20, 30, 33, and 50 ft (3,0, 6,1, 9,1, 10, and 15,2 m) lengths. Consult factory for non-standard lengths up to 75 ft (22,9 m). Remote mounting hardware includes a pipe mount bracket with one u-bolt. Armored remote cables are also available in lengths of 10, 20, 33, 50 and 75 feet. The armored remote option comes standard with glands/adapters to connect cable to meter body and transmitter housing. Remote cable is flame resistant in accordance with IEC 60332-3.

Temperature limitations for integral mounting

The maximum process temperature for integral mount electronics is dependent on the ambient temperature where the meter is installed. The electronics must not exceed 185 °F (85 °C). The following is for reference, please note that the pipe was insulated with 3 inches of ceramic fiber insulator.

Figure 1. Rosemount 8800 Vortex Flowmeter Ambient/Process Temperature Limits

Shows combinations of ambient and process temperatures needed to remain at or below 185 °F (85 °C) housing temperature.

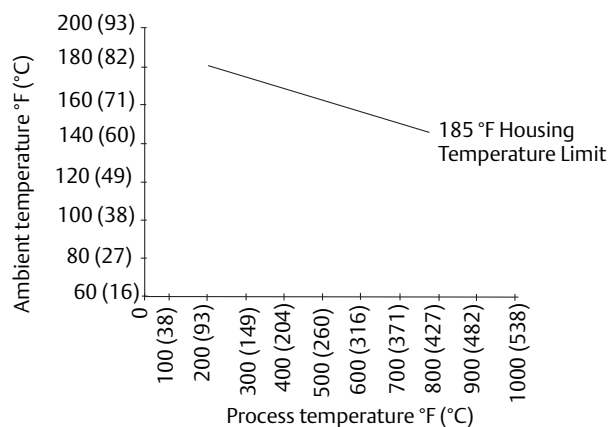

Meter and pipe insulated with 3 inches of ceramic fiber insulation.
Horizontal pipe and vertical meter position.

Pipe length requirements

The vortex meter may be installed with a minimum of ten diameters (D) of straight pipe length upstream and five diameters (D) of straight pipe length downstream.

Rated Accuracy is based on the number of pipe diameter from an upstream disturbance. No K-factor correction is required if the meter is installed with 35 D upstream and 5 D downstream. The value of the K-factor may shift up to 0.5% when the upstream straight pipe length is between 10D and 35D. Please see Technical Data Sheet (00816-0100-3250) on Installation Effects for optional K-factor corrections. This effect can be corrected in the electronics.

Tagging

The flowmeter will be tagged at no charge. All tags are stainless steel. The standard tag is permanently attached to the flowmeter. Character height is $\frac{1}{16}$ -in. (1,6 mm). A wired-on tag is available on request. Character height on the wire-on tag is 0.236-in. (6 mm). Wire on tags can contain five lines with an average of 19 characters per line at standard character height.

Flow calibration information

Flowmeter calibration and configuration information is provided with every flowmeter. For a certified copy of flow calibration data, Option Q4 must be ordered in the model number.

Product Certifications

Approved Manufacturing Locations

Rosemount Inc. — Eden Prairie, Minnesota, USA

Emerson Process Management BV - Ede, The Netherlands

Emerson Process Management Flow Technologies Company, Ltd
- Nanjing, Jiangsu Province, P.R. China

SC Emerson SRL - Cluj, Romania

Flameproof enclosure Ex d protection type in accordance with IEC 60079-1, EN 60079-1

- Transmitters with Flameproof enclosure type protection shall only be opened when power is removed.
- Closing of entries in the device must be carried out using the appropriate Ex d cable gland or blanking plug. Unless otherwise marked on housing, the standard conduit entry thread forms are 1/2-14 NPT.



Type n protection type in accordance with IEC 60079-15, EN60079-15

- Closing of entries in the device must be carried out using the appropriate Ex e or Ex n cable gland and metal blanking plug or any appropriate ATEX or IECEx approved cable gland and blanking plug with IP66 rating certified by an EU approved certification body.



European Directive Information

The CE Declaration of Conformity for all applicable European directives for this product can be found on our website at www.rosemount.com. A hard copy may be obtained by contacting our local sales office.

ATEX Directive

Rosemount Inc. complies with the ATEX Directive.

European Pressure Equipment Directive (PED)

Rosemount 8800D Vortex Flowmeter Line Size 40 mm to 300 mm

Certificate Number 4741-2014-CE-HOU-DNV
c 0575

Module H Conformity Assessment

Mandatory CE-marking for flowmeters in accordance with Article 15 of the PED can be found on the flowtube body. Flowmeter categories I – III use module H for conformity assessment procedures.

Rosemount 8800D Vortex Flowmeter Line Size 15 mm and 25 mm

Sound Engineering Practice

Flowmeters that are SEP are outside the scope of PED and cannot be marked for compliance with PED.

Hazardous Location Certifications

Rosemount 8800D

North American Certifications

Factory Mutual (FM)

- E5** Explosionproof-Intrinsically Safe for Class I, Division 1, Groups B, C, and D;
Dust-ignition proof for Class II/III, Division 1, Groups E, F, and G;
Temperature Code T6 (-50 °C ≤ Ta ≤ 70 °C)
Factory Sealed
Enclosure Type 4X, IP66
- I5** Intrinsically safe for use in Class I, II, III Division 1, Groups A, B, C, D, E, F, and G;
Non-incendive for Class I, Division 2, Groups A, B, C, and D
NIFW (Non-incendive Field Wiring) when installed per Rosemount Drawing 08800-0116
Temperature Code T4 (-50 °C ≤ Ta ≤ 70 °C) 4-20 mA HART
Temperature Code T4 (-50 °C ≤ Ta ≤ 60 °C) Fieldbus
Enclosure Type 4X, IP66
- IE** FISCO for Class I, II, III, Division 1, Groups A, B, C, D, E, F and G;
FNICO for Class 1 Division 2, Groups A, B, C, and D
Temperature Code T4 (-50 °C ≤ Ta ≤ 60 °C)
when installed per Rosemount control drawing 08800-0116
Enclosure Type 4X, IP66
- K5** E5 and I5 Combination

Special Conditions for Safe Use (X):

1. When fitted with 90V transient suppressors (T1 Option), the equipment is not capable of passing the 500V insulation test. This must be taken into account upon installation.
2. The Model 8800D Vortex Flowmeter when ordered with aluminum electronics housing is considered to constitute a potential risk of ignition by impact or friction. Care should be taken into account during installation and use to prevent impact or friction.

Canadian Standards Association (CSA)

- E6** Explosion-Proof for Class I, Division 1, Groups B, C, and D; Dust-ignition proof for Class II and Class III, Division 1, Groups E, F, and G
Class I, Zone 1, Ex d[ia] IIC
Temperature Code T6 (-50 °C ≤ Ta ≤ 70 °C)
Factory Sealed
Single Seal
Enclosure Type 4X
- I6** Intrinsically safe for use in Class I, II, III Division 1, Groups A, B, C, D, E, F, G;
Non-incendive for Class I, Division 2, Groups A, B, C and D
Temperature Code T4 (-50 °C ≤ Ta ≤ 70 °C) 4-20 mA HART
Temperature Code T4 (-50 °C ≤ Ta ≤ 60 °C) Fieldbus
Single Seal.
Enclosure Type 4X.
- IF** FISCO for Class I, Division 1, Groups A, B, C, and D;
FNICO for Class 1 Division 2, Groups A, B, C, and D.
Temperature Code T4 (-50 °C ≤ Ta ≤ 60 °C).
When installed per Rosemount drawing 08800-0112
Enclosure Type 4X

K6 E6 and I6 Combination

Combination Certifications

KB E5, I5, E6, and I6 Combination

European Certifications

ATEX Intrinsic Safety

EN 60079-0: 2012
EN 60079-11: 2012

- I1** Certification No. Baseefa05ATEX0084X
ATEX Marking
⊕ II 1 G Ex ia IIC T4 Ga (-60 °C ≤ Ta ≤ 70 °C) 4-20 HART
⊕ II 1 G Ex ia IIC T4 Ga (-60 °C ≤ Ta ≤ 60 °C) Fieldbus
cE 0575

4-20 mA HART entity parameters	Fieldbus entity parameters	FISCO input parameters
U _i = 30 VDC	U _i = 30 VDC	U _i = 17.5 VDC
I _i ⁽¹⁾ = 185 mA	I _i = 300 mA	I _i = 380 mA
P _i ⁽¹⁾ = 1.0 W	P _i = 1.3 W	P _i = 5.32 W
C _i = 0 μF	C _i = 0 μF	C _i = 0 μF
L _i < 0.97 mH	L _i < 10 μH	L _i < 10 μH

1. Total for transmitter.

ATEX FISCO

- IA** Certification No. Baseefa05ATEX0084X
ATEX Marking
⊕ II 1 G Ex ia IIC T4 Ga (-60 °C ≤ Ta ≤ 60 °C)
cE 0575

Special Conditions for Safe Use (X):

1. When fitted with 90V transient suppressors (T1 Option), the equipment is not capable of passing the 500V isolation test. This must be taken into account upon installation.
2. The enclosure may be made from aluminium alloy and given a protective polyurethane paint finish; however, care should be taken to protect it from impact or abrasion when located in Zone 0 environment. The polyurethane paint finish may constitute an electrostatic hazard and must only be cleaned with a damp cloth.
3. When the equipment is installed, particular precautions must be taken to ensure taking into account the effect of process fluid temperature, that the ambient temperature of the electrical housing of the equipment meets the marked protection type temperature range.

ATEX Type N Certification

EN 60079-0: 2012
EN 60079-11: 2012
EN 60079-15: 2010

- N1** Certification No. Baseefa05ATEX0085X
ATEX Marking
⊕ II 3 G Ex nA ic IIC T5 Gc (-50 °C ≤ Ta ≤ 70 °C) 4-20 mA HART
⊕ II 3 G Ex nA ic IIC T5 Gc (-50 °C ≤ Ta ≤ 60 °C) Fieldbus
Input Parameters:
Maximum Working Voltage = 42 VDC Max 4-20 mA HART
Maximum Working Voltage = 32 VDC Max Fieldbus

Special Conditions for Safe Use (X):

1. When fitted with 90V transient suppressors (T1 Option), the equipment is not capable of passing the 500V isolation test. This must be taken into account upon installation.
2. The enclosure may be made from aluminium alloy with a protective polyurethane paint finish. The polyurethane paint finish may constitute an electrostatic hazard and must only be cleaned with a damp cloth.
3. When the equipment is installed, particular precautions must be taken to ensure, taking into account the effect of process fluid temperature, that the ambient temperature of the electrical housing of the equipment meets the marked protection type temperature range.

ATEX Flameproof Certification

EN 60079-0: 2009
EN 60079-1: 2007
EN 60079-11: 2012

- E1** Certificate: KEMA99ATEX3852X
Integral Flowmeter marked:
⊕ II 1/2 G Ex d [ia] IIC T6 Ga/Gb (-50 °C ≤ Ta ≤ 70 °C)
Remote Transmitter marked:
⊕ II 2(1) G Ex d [ia Ga] IIC T6 Gb (-50 °C ≤ Ta ≤ 70 °C)
with meter body marked:
⊕ II 1 G Ex ia IIC T6 Ga (-50 °C ≤ Ta ≤ 70 °C)
42 VDC Max 4-20 mA HART
32 VDC Max Fieldbus
U_m = 250V

Installation instructions:

1. The cable and conduit entry devices shall be of a certified flameproof type Ex d, suitable for the conditions of use and correctly installed.
2. Unused apertures shall be closed with suitable blanking elements.
3. When the ambient temperature at the cable or conduit entries exceed 60 °C, cables suitable for at least 90 °C shall be used.
4. Remote mounted sensor; in type of protection EX ia IIC, only to be connected to the associated Model 8800D Vortex Flowmeter electronics. the maximum allowable length of the interconnecting cable is 152 m (500 ft).

Special Conditions for Safe Use (X):

1. For information regarding the dimensions of the flameproof joints, the manufacturer shall be contacted.
2. The Flowmeter shall be provided with special fasteners of property class A2-70 or A4-70.
3. Units marked with “Warning: Electrostatic Charging Hazard” may use non-conductive paint thicker than 0.2 mm. Precaution shall be taken to avoid ignition due to electrostatic charge on the enclosure.

K1 E1, I1, and N1 Combination

International IECEx Certifications

Intrinsic Safety

IEC 60079-0: 2011
IEC 60079-11: 2011

I7 Certificate No. IECEx BAS05.0028X
Ex ia IIC T4 Ga (-60 °C ≤ Ta ≤ 70 °C) 4-20 mA HART
(-60 °C ≤ Ta ≤ 60 °C) Fieldbus

4-20 mA HART entity parameters	Fieldbus entity parameters	FISCO input parameters
U _i = 30 VDC	U _i = 30 VDC	U _i = 17.5 VDC
I _i ⁽¹⁾ = 185 mA	I _i = 300 mA	I _i = 380 mA
P _i ⁽¹⁾ = 1.0 W	P _i = 1.3 W	P _i = 5.32 W
C _i = 0 μF	C _i = 0 μF	C _i = 0 μF
L _i < 0.97 mH	L _i < 10 μH	L _i < 10 μH

1. Total for transmitter.

FISCO

IG Certificate: IECEx BAS 05.0028X
Ex ia IIC T4 Ga (-60 °C ≤ Ta ≤ 60 °C)

Special Conditions for Safe Use (X):

1. When fitted with 90V transient suppressors (T1 Option), the equipment is not capable of passing the 500V isolation test. This must be taken into account upon installation.
2. The enclosure may be made from aluminium alloy and given a protective polyurethane paint finish; however, care should be taken to protect it from impact or abrasion when located in Zone 0 environment. The polyurethane paint finish may constitute an electrostatic hazard and must only be cleaned with a damp cloth.
3. When the equipment is installed, particular precautions must be taken to ensure, taking into account the effect of process fluid temperature, that the ambient temperature of the electrical housing of the equipment meets the marked protection type temperature range.

Type n Certification

IEC 60079-0: 2011
IEC 60079-11: 2011
IEC 60079-15: 2010

N7 Certificate No. IECEx BAS05.0029X
Ex nA ic IIC T5 Gc (-50 °C ≤ Ta ≤ 70 °C) 4-20 mA HART
Ex nA ic IIC T5 Gc (-50 °C ≤ Ta ≤ 60 °C) Fieldbus
Maximum Working Voltage = 42 VDC 4-20 mA HART
Maximum Working Voltage = 32 VDC Fieldbus

Special Conditions for Safe Use (X):

1. When fitted with 90V transient suppressors (T1 Option), the equipment is not capable of passing the 500V isolation test. This must be taken into account upon installation.
2. The enclosure may be made from aluminium alloy with a protective polyurethane paint finish. The polyurethane paint finish may constitute an electrostatic hazard and must only be cleaned with a damp cloth.
3. When the equipment is installed, particular precautions must be taken to ensure, taking into account the effect of process fluid temperature, that the ambient temperature of the electrical housing of the equipment meets the marked protection type temperature range.

Flameproof Certification

IEC 60079-0: 2007-10
IEC 60079-1: 2007-04
IEC 60079-11: 2011
IEC 60079-26: 2006

E7 Certificate: IECEx KEM05.0017X
Integral Flowmeter marked:
Ex d [ia] IIC T6 Ga/Gb (-50 °C ≤ Ta ≤ 70 °C)
Remote Transmitter marked:
Ex d [ia Ga] IIC T6 Gb(-50 °C ≤ Ta ≤ 70 °C)
with meter body marked:
Ex ia IIC T6 Ga (-50 °C ≤ Ta ≤ 70 °C)
42 VDC Max 4-20 mA HART
32 VDC Max Fieldbus
U_m = 250V

Installation instructions:

1. The cable and conduit entry devices shall be of a certified flameproof type Ex d, suitable for the conditions of use and correctly installed.
2. Unused apertures shall be closed with suitable blanking elements.
3. When the ambient temperature at the cable or conduit entries exceed 60 °C, cables suitable for at least 90 °C shall be used.
4. The remote mounted sensor may only be connected to the transmitter with the associated cable, supplied by the manufacturer.

Special Conditions for Safe Use (X):

1. For information regarding the dimensions of the flameproof joints, the manufacturer shall be contacted.
2. The Flowmeter shall be provided with special fasteners of property class A2-70 or A4-70.
3. Units marked with “Warning: Electrostatic Charging Hazard” may use non-conductive paint thicker than 0.2 mm. Precaution shall be taken to avoid ignition due to electrostatic charge on the enclosure.

Combination Certifications

K7 E7, I7, and N7 Combination

Chinese Certifications (NEPSI)

Flameproof Certification

- GB3836.1 – 2010
- GB3836.2 – 2010
- GB3836.4 – 2010
- GB3836.20 – 2010

E3 Certification No. GYJ12.1493X
 Ex ia / d IIC T6 Ga/Gb (Integral Transmitter)
 Ex d [ia Ga] IIC T6 Gb (Remote Transmitter)
 Ex ia IIC T6 Ga (Remote Sensor)
 Ambient temperature range: -50 °C ≤ Ta ≤ +70 °C
 Process temperature range: -202 °C to +427 °C
 Power Supply: 42 Vdc Max 4-20 mA HART
 Power Supply: 32 Vdc Max Fieldbus

Special Conditions for Safe Use (X):

1. The maximum allowable length of the interconnecting cable between transmitter and sensor is 152 m. The cable shall also be provided by Rosemount Inc., or by Emerson Process Management Flow Technologies Co., Ltd.
2. Suitable heat-resisting cables rated at least +80 °C shall be used when the temperature around the cable entry exceeds +60 °C.
3. Dimensions of flameproof joints are other than the relevant minimum or maximum specified in Table 3 of GB3836.2-2010. Contact manufacturer for details.
4. The Flowmeter is provided with special fasteners of property class A2-70 or A4-70.

5. Any friction should be prevented in order to avoid the risk of electrostatic charge on the enclosure due to non-conductive paint.
6. The earthing terminal should be connected to the ground reliably at site.
7. Do not open when energized.
8. The cable entry holes have to be connected by means of suitable entry device or stopping plugs with type of protection of Ex d IIC Gb the cable entry device and stopping plugs are approved in accordance with GB3836.1-2010 and GB3836.2-2010, and which are covered by a separate examination certificate, any unused entry hole is to be fitted with type of protection of Ex d IIC Gb flameproof stopping plug.
9. Users are forbidden to change the configuration to ensure the explosion protection performance of the equipment. Any faults shall be settled with experts from the manufacturer.
10. Precautions shall be taken to ensure that the electronic parts are within permissible ambient temperature considering the effect of the allowed fluid temperature.
11. During installation, operation and maintenance, users shall comply with the relevant requirements of the product instruction manual, GB3836.13-1997 “Electrical apparatus for explosive gas atmospheres Part 13: Repair and overhaul for apparatus used in explosive gas atmospheres”, GB3836.15-2000 “Electrical apparatus for explosive gas atmospheres Part 15: Electrical installations in hazardous areas (other than mines)”, GB3836.16-2006 “Electrical apparatus for explosive gas atmospheres Part 16: Inspection and maintenance of electrical installation (other than mines)”, and GB50257-1996 “Code for construction and acceptance of electrical device for explosion atmospheres and fire hazard electrical equipment installation engineering”.

I. S. Certification

- GB3836.1 – 2010
- GB3836.20 – 2010
- GB3836.4 – 2010
- GB12476.1 – 2010

I3 Certification No. GYJ12.1106X
 Ex ia IIC T4 Ga (-60 °C ≤ Ta ≤ + 70 °C) HART
 Ex ia IIC T4 Ga (-60 °C ≤ Ta ≤ + 60 °C) Fieldbus

4-20 mA HART entity parameters	Fieldbus entity parameters	FISCO input parameters
U _i = 30 VDC	U _i = 30 VDC	U _i = 17.5 VDC
I _i ⁽¹⁾ = 185 mA	I _i = 300 mA	I _i = 380 mA
P _i ⁽¹⁾ = 1.0 W	P _i = 1.3 W	P _i = 5.32 W
C _i = 0 μF	C _i = 0 μF	C _i = 0 μF
L _i ≤ 0.97 mH	L _i ≤ 10 μH	L _i ≤ 10 μH

1. Total for transmitter.

FISCO/FINCO

IH Certification No. IECEx BAS 05.0028X
Ex ia IIC T4 Ga (-60 °C ≤ T_a ≤ +60 °C)

Special Conditions for Safe Use (X):

1. The maximum allowable length of the interconnecting cable between transmitter and sensor is 152 m. The cable shall also be provided by manufacturer.
2. When transient protection terminal block applied to this product, during installation, users shall comply with Clause 12.2.4 in GB3836.15-2000 “Electrical apparatus for explosive gas atmospheres Part 15: Electrical installations in hazardous areas (other than mines).”
3. Suitable heat-resisting cables rated at least +80 °C shall be used when the temperature around the cable entry exceeds +60 °C.
4. Only be connected to the certified associated apparatus, the Vortex Flowmeter could be used in the explosive atmosphere. The connection should be complied with the requirements of the manual of the associated apparatus and the Vortex Flowmeter.
5. The enclosure should be taken to protect it from impact.
6. Any friction should be prevented in order to avoid the risk of electrostatic charge on the enclosure due to non-conductive paint.
7. The cable with shield is suitable for connection, and the shield should be connected to earth.
8. The enclosure shall be kept from the dust, but the dust shall not be blown by compressed air.
9. The cable entry holes have to be connected by means of suitable cable entry, the way of being installed shall be ensure that the equipment satisfies degree of protection IP66 according to GB4208-2008.
10. Users are forbidden to change the configuration to ensure the explosion protection performance of the equipment. Any faults shall be settled with experts from the manufacturer.
11. Precautions shall be taken to ensure that the electronic parts are within permissible ambient temperature considering the effect of the allowed fluid temperature.
12. During installation, operation and maintenance, users shall comply with the relevant requirements of the product instruction manual, GB3836.13- 1997 “Electrical apparatus for explosive gas atmospheres Part 13: Repair and overhaul for apparatus used in explosive gas atmospheres”, GB3836.15-2000 “Electrical apparatus for explosive gas atmospheres Part 15: Electrical installations in hazardous areas (other than mines)”, GB3836.16-2006 “Electrical apparatus for explosive gas atmospheres Part 16: Inspection and maintenance of electrical installation (other than mines)”, and GB50257-1996 “Code for construction and acceptance of electrical device for explosion atmospheres and fire hazard electrical equipment installation engineering”.

Type “n” Certification

GB3836.1 – 2010
GB3836.8 – 2003
GB3836.4 – 2010

Special Conditions for Safe Use (X):

1. The maximum allowable length of the interconnecting cable between transmitter and sensor is 152 m. The cable shall also be provided by the manufacturer.
2. Suitable heat-resisting cables rated at least +80 °C shall be used when the temperature around the cable entry exceeds +60 °C.
3. When transient protection terminal block (The Other Option is T1) applied to this product, during installation, users shall comply with Clause 12.2.4 in GB3836.15-2000 “Electrical apparatus for explosive gas atmospheres Part 15: Electrical installations in hazardous areas (other than mines).”
4. Any friction should be prevented in order to avoid the risk of electrostatic charge on the enclosure due to non-conductive paint.
5. Do not open when energized.
6. The cable entry holes have to be connected by means of suitable cable entry, the way of being installed shall be ensure that the equipment satisfies degree of protection IP54 according to GB4208-2008.
7. Users are forbidden to change the configuration to ensure the explosion protection performance of the equipment. Any faults shall be settled with experts from the manufacturer.
8. Precautions shall be taken to ensure that the electronic parts are within permissible ambient temperature considering the effect of the allowed fluid temperature.
9. During installation, operation and maintenance, users shall comply with the relevant requirements of the product instruction manual, GB3836.13- 1997 “Electrical apparatus for explosive gas atmospheres Part 13: Repair and overhaul for apparatus used in explosive gas atmospheres”, GB3836.15-2000 “Electrical apparatus for explosive gas atmospheres Part 15: Electrical installations in hazardous areas (other than mines)”, GB3836.16-2006 “Electrical apparatus for explosive gas atmospheres Part 16: Inspection and maintenance of electrical installation (other than mines)”, and GB50257-1996 “Code for construction and acceptance of electrical device for explosion atmospheres and fire hazard electrical equipment installation engineering”.

Combination Certifications: China

K3 E3, I3, and N3 Combination

Brazilian Certifications - INMETRO

I. S. Certification

ABNT NBR IEC 60079-0: 2008
 ABNT NBR IEC 60079-11: 2009
 ABNT NBR IEC 60079-26: 2008

I2 Certification Number: NCC 11.0699 X
 Ex ia IIC T4 Ga (-60 °C ≤ Ta ≤ + 70 °C) HART
 Ex ia IIC T6 Ga (-50 °C ≤ Ta ≤ + 60 °C) Fieldbus

IB Certification Number: NCC 11.0699 X
 Ex ia IIC T4 Ga (-60 °C ≤ Ta ≤ + 60 °C) FISCO

4-20 mA HART entity parameters	Fieldbus entity parameters	FISCO input parameters
$U_i = 30 \text{ VDC}$	$U_i = 30 \text{ VDC}$	$U_i = 17.5 \text{ VDC}$
$I_i^{(1)} = 185 \text{ mA}$	$I_i = 300 \text{ mA}$	$I_i = 380 \text{ mA}$
$P_i^{(1)} = 1.0 \text{ W}$	$P_i = 1.3 \text{ W}$	$P_i = 5.32 \text{ W}$
$C_i = 0 \mu\text{F}$	$C_i = 0 \mu\text{F}$	$C_i = 0 \mu\text{F}$
$L_i \leq 0.97 \text{ mH}$	$L_i \leq 10 \mu\text{H}$	$L_i \leq 10 \mu\text{H}$

1. Total for transmitter.

Special Conditions for Safe Use (X):

- When fitted with 90V transient suppressors, the equipment is not capable of passing the 500V insulation test. This must be taken into account upon installation.
- The enclosure may be made from aluminum alloy with a protective polyurethane paint finish; however, care should be taken to protect it from impact or abrasion when located in Zone 0. The polyurethane paint finish may constitute an electrostatic hazard and must only be cleaned with a damp cloth.
- When the equipment is installed, particular precautions must be taken to ensure, taking into account the effect of process fluid temperature, that the ambient temperature of the electrical housing of the equipment meets the marked protection type temperature range.

Flameproof Certification

ABNT NBR IEC 60079-0: 2008
 ABNT NBR IEC 60079-1: 2009
 ABNT NBR IEC 60079-11: 2009
 ABNT NBR IEC 60079-26: 2008

E2 Certification Number: NCC 11.0622 X
 Ex d [ia] IIC T6 Ga/Gb (Integral Transmitter)
 Ex d [ia Ga] IIC T6 Gb (Remote Transmitter)
 Ex ia IIC T6 Ga (Remote Sensor)
 Ambient temperature range: -50 °C ≤ Ta ≤ +70 °C
 Process temperature range: -202 °C to +427 °C
 Power Supply: 42 Vdc Max 4-20 mA HART
 Power Supply: 32 Vdc Max Fieldbus
 Transmitter Um = 250 V

Remote mounted sensor

In type of protection Ex ia IIC, only to be connected to the associated Model 8800D Vortex Flowmeter electronics. The maximum length of the interconnecting cable is 152 m (500 ft).

Special Conditions for Safe Use (X):

- For information regarding the dimensions of the flameproof joints, the manufacturer shall be contacted.
- The Flowmeter is provided with special fasteners of property class A2-70 of A4-70.
- Units marked with “Warning: Electrostatic Charging Hazard” may use non-conductive paint thicker than 0.2 mm. Precautions shall be taken to avoid ignition due to electrostatic charge of the enclosure.

Combined Certifications: INMETRO

K3 E2 and I2 Combination

Dimensional Drawings

Figure 2. Flanged-Style Flowmeter (1/2- through 12-in./15 mm through 300 mm Line Sizes)

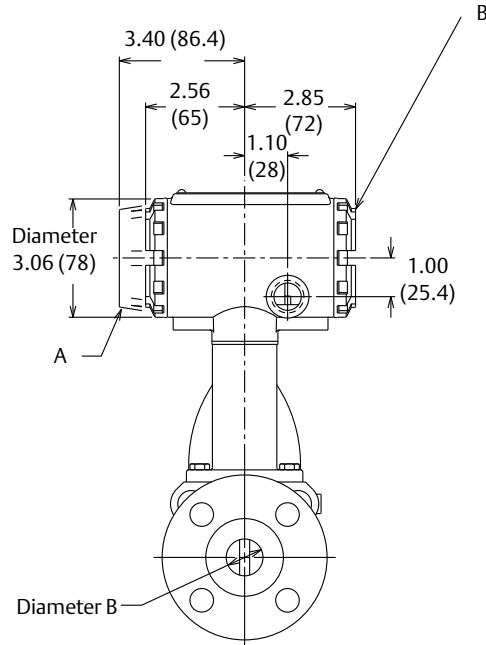

A. Display option
 B. Terminal cover

Diagram illustrated without MTA option

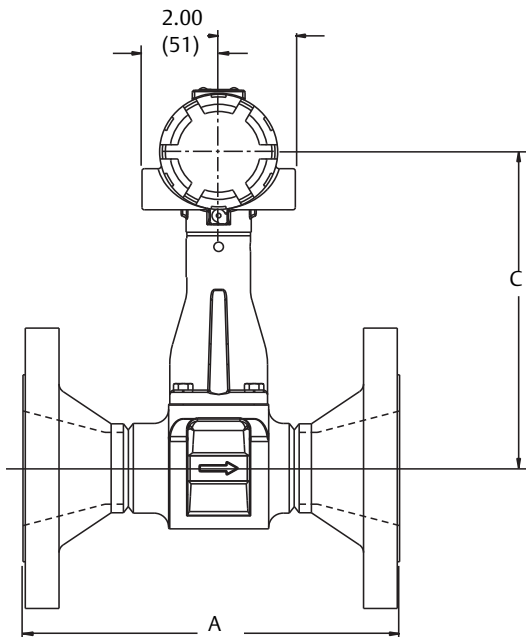
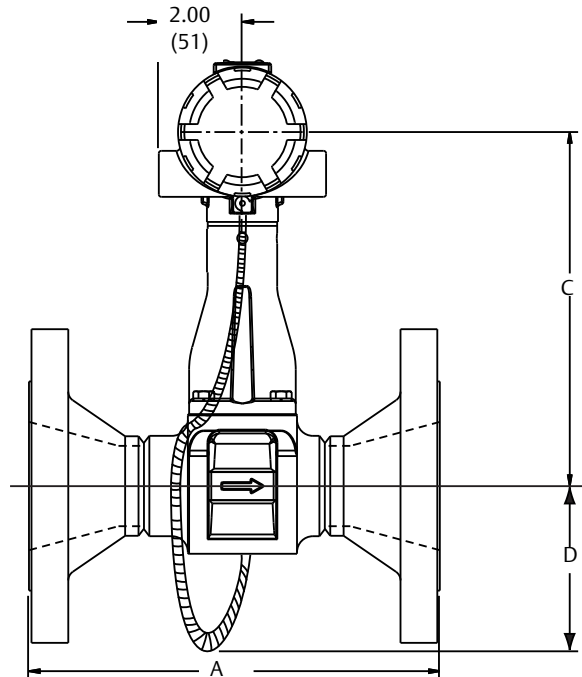

Diagram illustrated with MTA option



Dimensions are in inches (millimeters).

Table 21. Flanged-Style Flowmeter (1/2- through 2-in./15 mm through 50 mm Line Sizes)

Nominal size inch (mm)	Flange rating	Face-to-face A inch (mm)	A-ANSI RTJ inch (mm)	Diameter B inch (mm)	C inch (mm)	Weight lb (kg)	
1/2 (15)	Class 150	6.8 (173)	N/A	0.54 (13,7)	7.6 (193)	9.1 (4,1)	
	Class 300	7.2 (183)	7.6 (193)	0.54 (13,7)	7.6 (193)	10.4 (4,7)	
	Class 600	7.7 (196)	7.6 (193)	0.54 (13,7)	7.6 (193)	10.8 (4,9)	
	Class 900	8.3 (211)	8.3 (211)	0.54 (13,7)	7.6 (193)	15.3 (6,9)	
	PN 16/40	6.1 (155)	N/A	0.54 (13,7)	7.6 (193)	10.4 (4,7)	
	PN 100	6.6 (168)	N/A	0.54 (13,7)	7.6 (193)	12.4 (5,6)	
	JIS 10K/20K	6.3 (160)	N/A	0.54 (13,7)	7.6 (193)	10.2 (4,6)	
	JIS 40K	7.3 (185)	N/A	0.54 (13,7)	7.6 (193)	13.7 (6,2)	
	1 (25)	Class 150	7.5 (191)	8.0 (203)	0.95 (24,1)	7.7 (196)	12.3 (5,6)
Class 300		8.0 (203)	8.5 (216)	0.95 (24,1)	7.7 (196)	15.0 (6,8)	
Class 600		8.5 (216)	8.5 (216)	0.95 (24,1)	7.7 (196)	15.8 (7,2)	
Class 900		9.4 (239)	9.4 (239)	0.95 (24,1)	7.7 (196)	24.1 (11,1)	
Class 1500		9.4 (239)	9.4 (239)	0.95 (24,1)	7.7 (196)	24.4 (11,1)	
PN 16/40		6.2 (157)	N/A	0.95 (24,1)	7.7 (196)	13.6 (6,2)	
PN 100		7.7 (196)	N/A	0.95 (24,1)	7.7 (196)	19.6 (8,9)	
PN 160		7.7 (196)	N/A	0.95 (24,1)	7.7 (196)	19.6 (8,9)	
JIS 10K/20K		6.5 (165)	N/A	0.95 (24,1)	7.7 (196)	14.0 (6,3)	
JIS 40K		7.8 (198)	N/A	0.95 (24,1)	7.7 (196)	17.7 (7,9)	
1 1/2 (40)		Class 150	8.2 (208)	8.7 (221)	1.49 (37,8)	8.1 (206)	17.6 (8,0)
		Class 300	8.7 (221)	9.2 (234)	1.49 (37,8)	8.1 (206)	23.0 (10,4)
	Class 600	9.3 (236)	9.3 (236)	1.49 (37,8)	8.1 (206)	25.5 (11,6)	
	Class 900	10.3 (262)	10.3 (262)	1.49 (37,8)	8.1 (206)	36.6 (16,6)	
	Class 1500	10.3 (262)	10.3 (262)	1.49 (37,8)	8.1 (206)	36.6 (16,6)	
	PN 16/40	6.9 (175)	N/A	1.49 (37,8)	8.1 (206)	19.4 (8,8)	
	PN 100	8.2 (208)	N/A	1.49 (37,8)	8.1 (206)	28.0 (12,7)	
	PN 160	8.4 (213)	N/A	1.49 (37,8)	8.1 (206)	29.5 (13,4)	
	JIS 10K/20K	7.3 (185)	N/A	1.49 (37,8)	8.1 (206)	18.6 (8,4)	
	JIS 40K	8.4 (213)	N/A	1.49 (37,8)	8.1 (206)	25.5 (11,6)	
	2 (50)	Class 150	9.2 (234)	9.7 (246)	1.92 (48,8)	8.5 (216)	22.0 (10,0)
		Class 300	9.7 (246)	10.4 (264)	1.92 (48,8)	8.5 (216)	26.1 (11,8)
Class 600		10.5 (267)	10.6 (269)	1.92 (48,8)	8.5 (216)	29.8 (13,5)	
Class 900		12.7 (323)	12.9 (328)	1.92 (48,8)	8.5 (216)	59.5 (27,0)	
Class 1500		12.7 (323)	12.9 (328)	1.79 (45,5)	8.5 (216)	59.5 (27,0)	
PN 16/40		8.0 (203)	N/A	1.92 (48,8)	8.5 (216)	23.2 (10,5)	
PN 63/64		9.1 (231)	N/A	1.92 (48,8)	8.5 (216)	30.8 (13,9)	
PN 100		9.6 (244)	N/A	1.92 (48,8)	8.5 (216)	36.5 (16,6)	
PN 160		10.2 (259)	N/A	1.92 (48,8)	8.5 (216)	38.8 (17,6)	
JIS 10K		7.7 (195)	N/A	1.92 (48,8)	8.5 (216)	19.5 (8,8)	
JIS 20K		8.3 (210)	N/A	1.92 (48,8)	8.5 (216)	20.4 (9,3)	
JIS 40K		9.8 (249)	N/A	1.92 (48,8)	8.5 (216)	28.5 (12,9)	

Table 22. Flanged-Style Flowmeter (3- through 6-in./80 mm through 150 mm Line Sizes) (refer to previous drawing)

Nominal size inch (mm)	Flange rating	Face-to-face A inch (mm)	A ANSI RTJ inch (mm)	Diameter B inch (mm)	C inch (mm)	Weight lb (kg)
3 (80)	Class 150	9.9 (251)	10.4 (264)	2.87 (72,9)	9.1 (231)	37.2 (16,9)
	Class 300	10.6 (269)	11.2 (284)	2.87 (72,9)	9.1 (231)	46.5 (21,1)
	Class 600	11.4 (290)	11.5 (292)	2.87 (72,9)	9.1 (231)	52.6 (23,8)
	Class 900	12.9 (328)	13.0 (330)	2.87 (72,9)	9.1 (231)	76.1 (34,5)
	Class 1500	14.1 (358)	14.2 (361)	2.60 (66)	9.1 (231)	108.9 (49,4)
	PN 16/40	8.9 (226)	–	2.87 (72,9)	9.1 (231)	36.6 (16,6)
	PN 63/64	10.0 (254)	–	2.87 (72,9)	9.1 (231)	45.3 (20,6)
	PN 100	10.5 (267)	–	2.87 (72,9)	9.1 (231)	54.7 (24,8)
	PN 160	11.1 (282)	–	2.87 (72,9)	9.1 (231)	59.6 (27,0)
	JIS 10K	7.9 (201)	–	2.87 (72,9)	9.1 (231)	28.0 (12,7)
	JIS 20K	9.3 (236)	–	2.87 (72,9)	9.1 (231)	35.4 (16,1)
	JIS 40K	11.0 (279)	–	2.87 (72,9)	9.1 (231)	50.3 (22,8)
	4 (100)	Class 150	10.3 (262)	10.8 (274)	3.79 (96,3)	9.6 (244)
Class 300		11.0 (279)	11.6 (295)	3.79 (96,3)	9.6 (244)	71.5 (32,4)
Class 600		12.8 (325)	12.9 (328)	3.79 (96,3)	9.6 (244)	97.5 (44,2)
Class 900		13.8 (351)	13.9 (353)	3.79 (96,3)	9.6 (244)	120.8 (54,8)
Class 1500		14.5 (368)	14.6 (371)	3.40 (86,4)	9.6 (244)	162.6 (73,8)
PN 16		8.4 (213)	–	3.79 (96,3)	9.6 (244)	40.4 (18,3)
PN 40		9.4 (239)	–	3.79 (96,3)	9.6 (244)	49.5 (22,4)
PN 63/64		10.4 (264)	–	3.79 (96,3)	9.6 (244)	62.5 (28,3)
PN 100		11.3 (287)	–	3.79 (96,3)	9.6 (244)	78.9 (35,8)
PN 160		12.1 (307)	–	3.79 (96,3)	9.6 (244)	86.2 (39,1)
JIS 10K		8.7 (220)	–	3.79 (96,3)	9.6 (244)	37.5 (17,0)
JIS 20K		8.7 (220)	–	3.79 (96,3)	9.6 (244)	45.4 (20,6)
JIS 40K		11.8 (300)	–	3.79 (96,3)	9.6 (244)	75.8 (34,4)
6 (150)	Class 150	11.6 (295)	12.1 (307)	5.7 (144,8)	10.8 (274)	81 (37)
	Class 300	12.3 (312)	13.0 (330)	5.7 (144,8)	10.8 (274)	120 (55)
	Class 600	14.3 (363)	14.4 (366)	5.7 (144,8)	10.8 (274)	187 (55)
	Class 900	16.1 (409)	16.2 (411)	5.14 (130,6)	10.8 (274)	277.9 (126,0)
	Class 1500	18.6 (472)	18.8 (478)	5.14 (130,6)	10.8 (274)	375.8 (170,4)
	PN 16	8.9 (226)	–	5.7 (144,8)	10.8 (274)	66 (30)
	PN 40	10.5 (267)	–	5.7 (144,8)	10.8 (274)	86 (39)
	PN 63/64	12.1 (307)	–	5.7 (144,8)	10.8 (274)	130 (59)
	PN 100	13.6 (345)	–	5.7 (144,8)	10.8 (274)	160 (73)
	JIS 10K	10.6 (270)	–	5.7 (144,8)	10.8 (274)	70 (32)
	JIS 20K	10.6 (270)	–	5.7 (144,8)	10.8 (274)	88 (40)
	JIS 40K	14.2 (361)	–	5.7 (144,8)	10.8 (274)	166 (75)

Table 23. Flanged-Style Flowmeter (8- through 12-in./200 mm through 300 mm Line Sizes) (refer to previous drawing)

Nominal size inch (mm)	Flange rating	Face-to-face A inch (mm)	A ANSI RTJ inch (mm)	Diameter B inch (mm)	C inch (mm)	Weight lb (kg)
8 (200)	Class 150	13.5 (343)	14.0 (356)	7.55 (191,8)	11.7 (297)	141.6 (64,2)
	Class 300	14.3 (363)	14.9 (378)	7.55 (191,8)	11.7 (297)	198.7 (90,1)
	Class 600	16.5 (419)	16.7 (424)	7.55 (191,8)	11.7 (297)	298.6 (135,4)
	Class 900	18.8 (478)	18.9 (480)	6.62 (168,1)	11.7 (297)	479.2 (217,4)
	Class 1500	22.8 (579)	23.2 (589)	6.62 (168,1)	11.7 (297)	652.4 (295,9)
	PN 10	10.4 (264)	–	7.55 (191,8)	11.7 (297)	110.5 (50,1)
	PN 16	10.4 (264)	–	7.55 (191,8)	11.7 (297)	109.4 (49,6)
	PN 25	11.8 (300)	–	7.55 (191,8)	11.7 (297)	137.7 (62,5)
	PN 40	12.5 (318)	–	7.55 (191,8)	11.7 (297)	156.5 (71,0)
	PN 63/64	14.2 (361)	–	7.55 (191,8)	11.7 (297)	217.1 (98,5)
	PN 100	15.8 (401)	–	7.55 (191,8)	11.7 (297)	282.7 (128,2)
	JIS 10K	12.2 (310)	–	7.55 (191,8)	11.7 (297)	110.1 (49,9)
	JIS 20K	12.2 (310)	–	7.55 (191,8)	11.7 (297)	134.5 (61,0)
	JIS 40K	16.5 (419)	–	7.55 (191,8)	11.7 (297)	255.7 (116)
	10 (250)	Class 150	14.5 (368)	15.0 (381)	9.56 (243)	12.8 (325)
Class 300		15.8 (401)	16.4 (417)	9.56 (243)	12.8 (325)	286.2 (129,8)
Class 600		19.0 (483)	19.2 (488)	9.56 (243)	12.8 (325)	477.9 (219,9)
PN 10		11.9 (302)	–	9.56 (243)	12.8 (325)	157.1 (71,3)
PN 16		12.0 (305)	–	9.56 (243)	12.8 (325)	161.9 (73,5)
PN 25		13.5 (343)	–	9.56 (243)	12.8 (325)	198.6 (90,1)
PN 40		14.8 (376)	–	9.56 (243)	12.8 (325)	246.8 (111,9)
PN 63/64		16.4 (417)	–	9.56 (243)	12.8 (325)	308.2 (139,8)
PN 100		18.9 (480)	–	9.56 (243)	12.8 (325)	445.2 (201,9)
JIS 10K		14.5 (368)	–	9.56 (243)	12.8 (325)	174.5 (79,1)
JIS 20K		14.5 (368)	–	9.56 (243)	12.8 (325)	221.8 (100,6)
JIS 40K		18.1 (460)	–	9.56 (243)	12.8 (325)	378.5 (171,7)
12 (300)	Class 150	16.8 (427)	17.3 (439)	11.38 (289)	13.7 (348)	297.5 (134,9)
	Class 300	18.0 (457)	18.6 (472)	11.38 (289)	13.7 (348)	415.7 (188,6)
	Class 600	20.5 (521)	20.6 (523)	11.38 (289)	13.7 (348)	595.4 (270,1)
	PN 10	13.1 (333)	–	11.38 (289)	13.7 (348)	204.1 (92,6)
	PN 16	13.9 (353)	–	11.38 (289)	13.7 (348)	224.6 (101,9)
	PN 25	15.0 (381)	–	11.38 (289)	13.7 (348)	269.4 (122,2)
	PN 40	16.8 (427)	–	11.38 (289)	13.7 (348)	347.9 (157,8)
	PN 63/64	18.8 (478)	–	11.38 (289)	13.7 (348)	431.2 (195,6)
	PN 100	21.2 (538)	–	11.38 (289)	13.7 (348)	644.1 (292,2)
	JIS 10K	15.7 (399)	–	11.38 (289)	13.7 (348)	222.9 (101,1)
	JIS 20K	15.7 (399)	–	11.38 (289)	13.7 (348)	284.2 (128,9)
	JIS 40K	19.6 (498)	–	11.38 (289)	13.7 (348)	493.8 (224,0)

Figure 3. Rosemount 8800DR Reducer Flowmeter (1- through 12-in./25 mm through 300 mm Line Sizes)

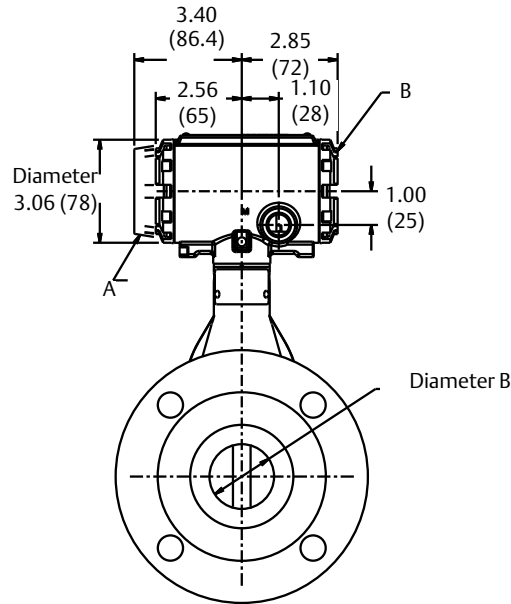

- A. Display option
- B. Terminal cover

Diagram illustrated without MTA option

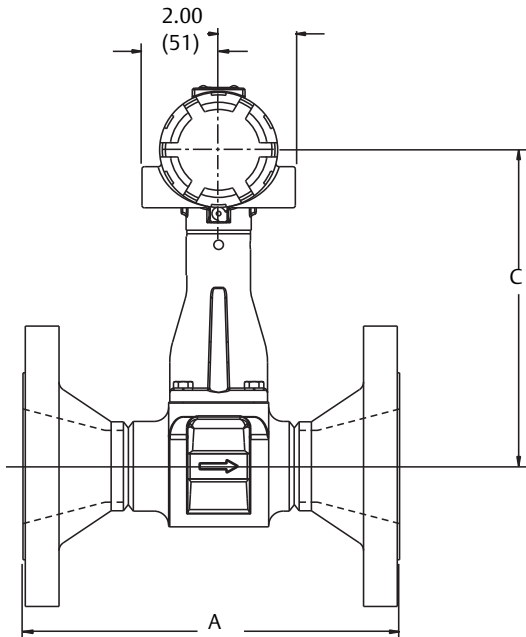
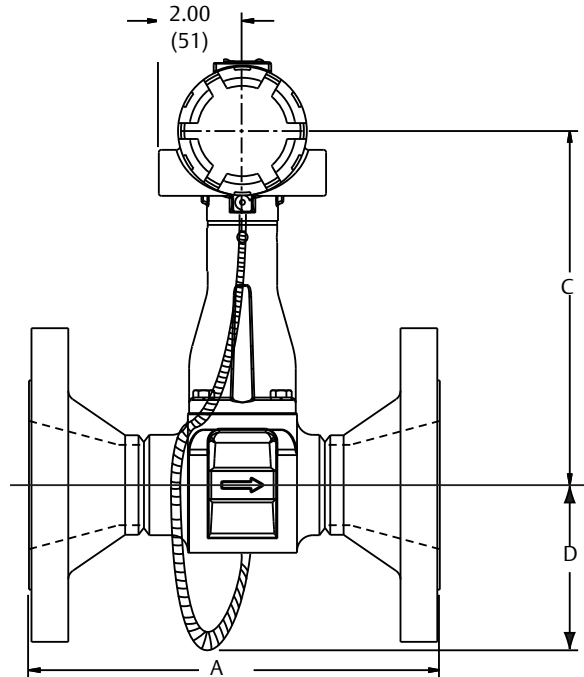

Diagram illustrated with MTA option



Dimensions are in inches (millimeters).

Table 24. Reducer Flowmeter (1- through 3-in./25 mm through 80 mm Line Sizes)

Nominal size inch (mm)	Flange rating	Face-to-face A inch (mm)	A-ANSI RTJ inch (mm)	Diameter B inch (mm)	C inch (mm)	Weight lb (kg)
1 (25)	Class 150	7.5 (191)	8.0 (203)	0.54 (13,7)	7.6 (193)	11.56 (5,24)
	Class 300	8.0 (203)	8.5 (216)	0.54 (13,7)	7.6 (193)	14.22 (6,45)
	Class 600	8.5 (216)	8.5 (216)	0.54 (13,7)	7.6 (193)	15.11 (6,85)
	Class 900	9.4 (239)	9.4 (239)	0.54 (13,7)	7.6 (193)	20.70 (9,40)
	PN 16/40	6.2 (157)	-	0.54 (13,7)	7.6 (193)	12.64 (5,73)
	PN 100	7.7 (196)	-	0.54 (13,7)	7.6 (193)	18.44 (8,36)
1 ½ (40)	Class 150	8.2 (208)	8.7 (221)	0.95 (24,1)	7.7 (196)	15.81 (7,17)
	Class 300	8.7 (221)	9.2 (234)	0.95 (24,1)	7.7 (196)	21.20 (9,62)
	Class 600	9.3 (236)	9.3 (236)	0.95 (24,1)	7.7 (196)	23.77 (10,78)
	Class 900	10.3 (262)	10.3 (262)	0.95 (24,1)	7.7 (196)	34.98 (15,87)
	PN 16/40	6.9 (175)	-	0.95 (24,1)	7.7 (196)	17.50 (7,94)
	PN 100	8.2 (208)	-	0.95 (24,1)	7.7 (196)	26.20 (11,88)
2 (50)	PN 160	8.4 (213)	-	0.95 (24,1)	7.7 (196)	27.67 (12,55)
	Class 150	9.2 (234)	9.7 (246)	1.49 (37,8)	8.1 (206)	22.61 (10,26)
	Class 300	9.7 (246)	10.4 (264)	1.49 (37,8)	8.1 (206)	26.76 (12,14)
	Class 600	10.5 (267)	10.6 (269)	1.49 (37,8)	8.1 (206)	30.59 (13,88)
	Class 900	12.7 (323)	12.9 (328)	1.49 (37,8)	8.1 (206)	60.76 (27,56)
	PN 16/40	8.0 (203)	-	1.49 (37,8)	8.1 (206)	23.52 (10,67)
3 (80)	PN 63/64	9.1 (231)	-	1.49 (37,8)	8.1 (206)	31.28 (14,19)
	PN 100	9.6 (244)	-	1.49 (37,8)	8.1 (206)	37.25 (16,90)
	PN 160	10.2 (259)	-	1.49 (37,8)	8.1 (206)	39.64 (17,98)
	Class 150	9.9 (251)	10.4 (264)	1.92 (48,8)	8.5 (216)	33.15 (15,04)
	Class 300	10.6 (269)	11.2 (284)	1.92 (48,8)	8.5 (216)	42.66 (19,35)
	Class 600	11.4 (290)	11.5 (292)	1.92 (48,8)	8.5 (216)	49.46 (22,43)
3 (80)	Class 900	12.9 (328)	13.0 (330)	1.92 (48,8)	8.5 (216)	73.28 (33,24)
	PN 16/40	8.9 (226)	-	1.92 (48,8)	8.5 (216)	33.30 (15,10)
	PN 63/64	10.0 (254)	-	1.92 (48,8)	8.5 (216)	42.45 (19,25)
	PN 100	10.5 (267)	-	1.92 (48,8)	8.5 (216)	52.21 (23,68)
	PN 160	11.1 (282)	-	1.92 (48,8)	8.5 (216)	57.94 (26,28)

Table 25. Reducer Flowmeter (4- through 12-in./100 mm –300 mm Line Sizes) (refer to previous drawing)

Nominal size inch (mm)	Flange rating	Face-to-face A inch (mm)	A ANSI RTJ inch (mm)	Diameter B inch (mm)	C inch (mm)	Weight lb (kg)
4 (100)	Class 150	10.3 (262)	10.8 (274)	2.87 (72,9)	9.1 (231)	46.33 (21,01)
	Class 300	11.0 (279)	11.6 (295)	2.87 (72,9)	9.1 (231)	67.04 (30,41)
	Class 600	12.8 (325)	12.9 (328)	2.87 (72,9)	9.1 (231)	94.26 (42,76)
	Class 900	13.8 (351)	13.9 (353)	2.87 (72,9)	9.1 (231)	118.04 (53,54)
	PN 16	8.4 (213)	–	2.87 (72,9)	9.1 (231)	36.36 (16,49)
	PN 40	9.4 (239)	–	2.87 (72,9)	9.1 (231)	45.89 (20,81)
	PN 63/64	10.4 (264)	–	2.87 (72,9)	9.1 (231)	59.72 (27,09)
	PN 100	11.3 (287)	–	2.87 (72,9)	9.1 (231)	76.73 (34,80)
6 (150)	PN 160	12.1 (307)	–	2.87 (72,9)	9.1 (231)	84.73 (38,43)
	Class 150	11.6 (295)	12.1 (307)	3.79 (96,3)	9.6 (244)	70.27 (31,87)
	Class 300	12.3 (312)	13.0 (330)	3.79 (96,3)	9.6 (244)	113.09 (51,30)
	Class 600	14.3 (363)	14.4 (366)	3.79 (96,3)	9.6 (244)	185.13 (83,97)
	Class 900	16.1 (409)	16.2 (411)	3.79 (96,3)	9.6 (244)	246.33 (111,73)
	PN 16	8.9 (226)	–	3.79 (96,3)	9.6 (244)	59.20 (26,85)
	PN 40	10.5 (267)	–	3.79 (96,3)	9.6 (244)	81.94 (37,17)
	PN 63/64	12.1 (307)	–	3.79 (96,3)	9.6 (244)	125.36 (56,86)
8 (200)	PN 100	13.6 (345)	–	3.79 (96,3)	9.6 (244)	162.29 (73,61)
	PN 160	14.7 (373)	–	3.79 (96,3)	9.6 (244)	187.91 (85,23)
	Class 150	13.5 (343)	14.0 (356)	5.70 (144,8)	10.8 (274)	124 (56)
	Class 300	14.3 (363)	14.9 (378)	5.70 (144,8)	10.8 (274)	186 (84)
	Class 600	16.5 (419)	16.7 (424)	5.70 (144,8)	10.8 (274)	295 (134)
	PN 10	10.4 (264)	–	5.70 (144,8)	10.8 (274)	91 (41)
	PN 16	10.4 (264)	–	5.70 (144,8)	10.8 (274)	91 (41)
	PN 25	11.8 (300)	–	5.70 (144,8)	10.8 (274)	124 (56)
10 (250)	PN 40	12.5 (318)	–	5.70 (144,8)	10.8 (274)	145 (66)
	PN 63/64	14.2 (361)	–	5.70 (144,8)	10.8 (274)	211 (96)
	PN 100	15.8 (401)	–	5.70 (144,8)	10.8 (274)	283 (128)
	Class 150	14.5 (368)	15.0 (381)	7.55 (191,8)	11.7 (297)	182.45 (82,76)
	Class 300	15.8 (401)	16.4 (417)	7.55 (191,8)	11.7 (297)	281.66 (127,76)
	Class 600	19.0 (483)	19.2 (488)	7.55 (191,8)	11.7 (297)	489.89 (222,21)
	PN 10	11.9 (302)	–	7.55 (191,8)	11.7 (297)	138.63 (62,88)
	PN 16	12.0 (305)	–	7.55 (191,8)	11.7 (297)	148.58 (67,39)
12 (300)	PN 25	13.5 (343)	–	7.55 (191,8)	11.7 (297)	191.00 (86,64)
	PN 40	14.8 (376)	–	7.55 (191,8)	11.7 (297)	245.85 (111,52)
	PN 63/64	16.4 (417)	–	7.55 (191,8)	11.7 (297)	314.13 (142,49)
	PN 100	18.9 (480)	–	7.55 (191,8)	11.7 (297)	463.49 (210,24)
	Class 150	16.8 (427)	17.3 (439)	9.56 (242,8)	12.8 (325)	281.98 (127,90)
	Class 300	18.0 (457)	18.6 (472)	9.56 (242,8)	12.8 (325)	412.18 (186,96)
	Class 600	20.5 (521)	20.6 (523)	9.56 (242,8)	12.8 (325)	609.89 (296,64)
	PN 10	13.1 (333)	–	9.56 (242,8)	12.8 (325)	188.28 (85,40)
12 (300)	PN 16	13.9 (353)	–	9.56 (242,8)	12.8 (325)	211.79 (96,07)
	PN 25	15.0 (381)	–	9.56 (242,8)	12.8 (325)	262.45 (119,05)
	PN 40	16.8 (427)	–	9.56 (242,8)	12.8 (325)	349.92 (158,72)
	PN 63/64	18.8 (478)	–	9.56 (242,8)	12.8 (325)	444.21 (201,49)
	PN 100	21.2 (538)	–	9.56 (242,8)	12.8 (325)	672.07 (304,85)

Figure 4. Wafer-Style (1/2- through 8-in./15 mm through 200 mm Line Sizes)

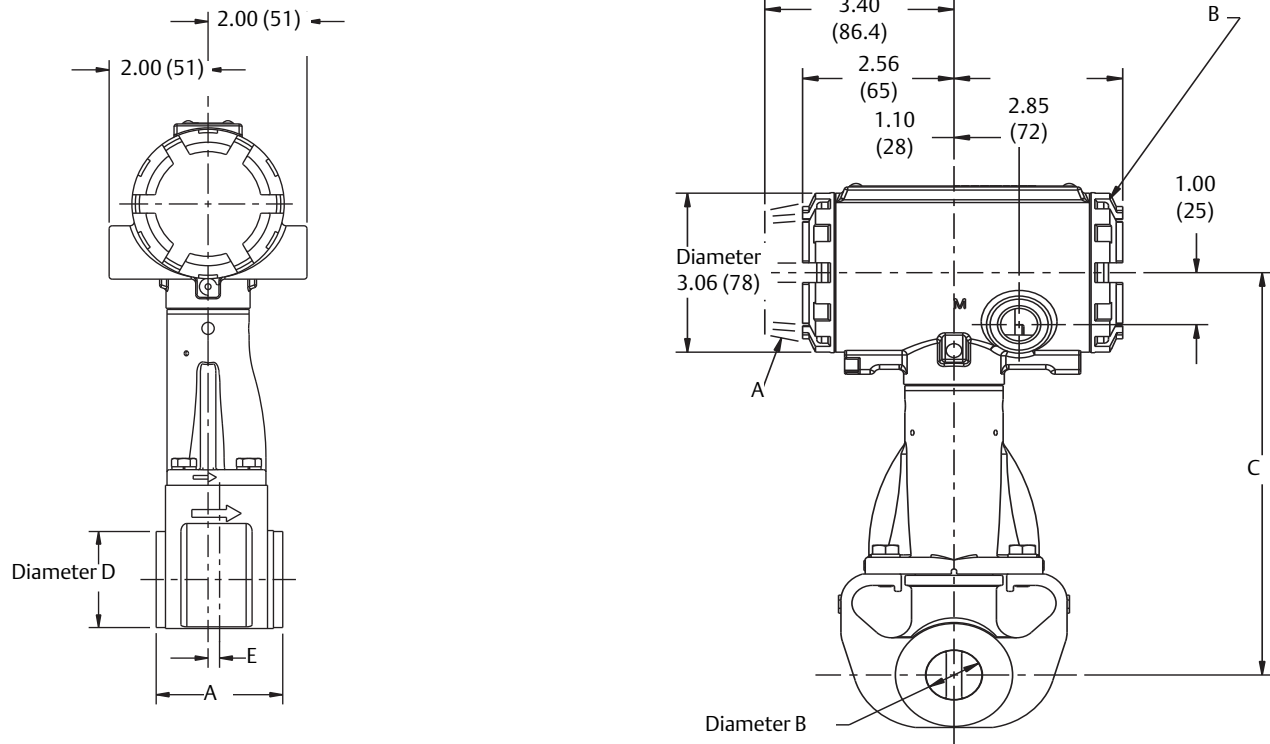

A. Display Option

B. Terminal Cover

Dimensions are in inches (millimeters).
 Electronics housing may be rotated in 90 degree increments.

Table 26. Rosemount 8800D Wafer-Style Meter

Nominal size inch (mm)	Face-to-face A inch (mm)	Diameter B inch (mm)	C inch (mm)	E inch (mm)	Weight lb (kg) ⁽¹⁾
1/2 (15)	2.56 (65)	0.52 (13,2)	7.63 (194)	0.17 (4,3)	6.8 (3,1)
1 (25)	2.56 (65)	0.95 (24,1)	7.74 (197)	0.23 (5,9)	7.4 (3,4)
1 1/2 (40)	2.56 (65)	1.49 (37,8)	8.14 (207)	0.18 (4,6)	10.0 (4,5)
2 (50)	2.56 (65)	1.92 (49)	8.85 (225)	0.12 (3)	10.6 (4,8)
3 (80)	2.56 (65)	2.87 (73)	9.62 (244)	0.25 (6)	13.6 (6,2)
4 (100)	3.42 (87)	3.79 (96)	10.48 (266)	0.44 (11)	21.4 (9,7)
6 (150)	5.00 (127)	5.70 (145)	10.29 (261)	0.30 (7,6)	36 (16)
8 (200)	6.60 (168)	7.55 (192)	11.22 (285)	0.70 (17,8)	62 (28)

1. Add 0.2 lb (0,1 kg) for display option.

Figure 5. Vortex Dual-Sensor Style Flowmeter (1/2- through 4-in. /15 mm through 100 mm Line Sizes)

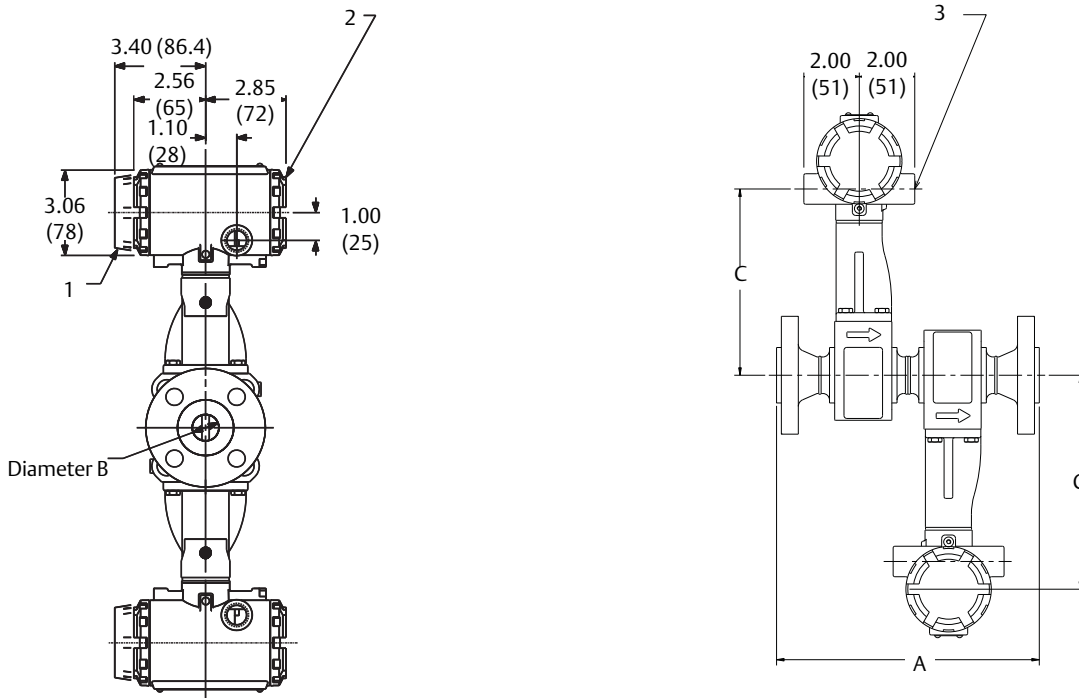

1. Display option
2. Terminal cover

3. Electrical connection

Figure 6. Vortex Dual-Sensor Style Flowmeter (6- through 12-in./150 mm through 300 mm Line Sizes)

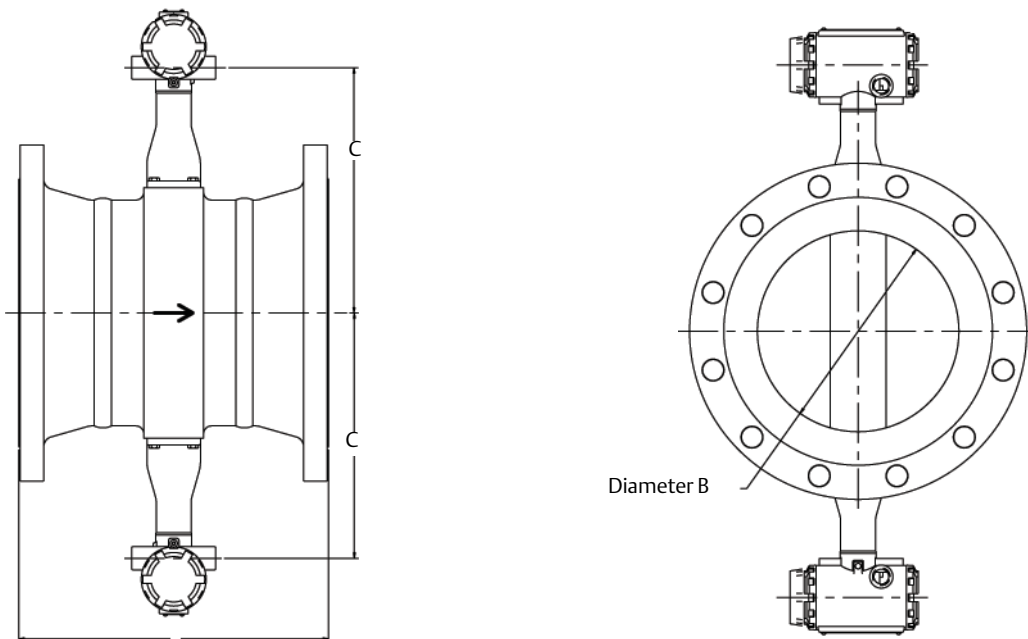

Dimensions are in inches (millimeters).

Table 27. Vortex Dual-Sensor Style Flowmeter (1/2- through 3-in./15 mm through 80 mm Line Sizes)

Nominal size inch (mm)	Flange rating	Face-to-face A inch (mm)	A ANSI RTJ inch (mm)	Diameter B inch (mm)	C inch (mm)	Weight lb (kg)
½ (15)	Class 150	11.9 (302)	–	0.54 (13,7)	7.6 (193)	16.2 (7,4)
	Class 300	12.3 (312)	12.7 (323)	0.54 (13,7)	7.6 (193)	17.4 (7,9)
	Class 600	12.8 (325)	12.7 (323)	0.54 (13,7)	7.6 (193)	17.9 (8,1)
	Class 900	13.4 (340)	13.4 (340)	0.54 (13,7)	7.6 (193)	22.7 (10,3)
	PN 16/40	11.2 (284)	–	0.54 (13,7)	7.6 (193)	17.4 (7,9)
	PN 100	11.7 (297)	–	0.54 (13,7)	7.6 (193)	19.4 (8,8)
1 (25)	JIS 10K/20K	11.4 (290)	–	0.54 (13,7)	7.6 (193)	17.3 (7,8)
	JIS 40K	12.4 (315)	–	0.54 (13,7)	7.6 (193)	20.8 (9,4)
	Class 150	15.0 (381)	15.6 (396)	0.95 (24,1)	7.7 (196)	20.7 (9,4)
	Class 300	15.6 (396)	16.1 (409)	0.95 (24,1)	7.7 (196)	23.3 (10,6)
	Class 600	16.1 (409)	16.1 (409)	0.95 (24,1)	7.7 (196)	24.2 (11,0)
	Class 900	16.9 (429)	16.9 (429)	0.95 (24,1)	7.7 (196)	32.8 (14,9)
1½ (40)	Class 1500	16.9 (429)	16.9 (429)	0.95 (24,1)	7.7 (196)	32.8 (14,9)
	PN 16/40	13.8 (351)	–	0.95 (24,1)	7.7 (196)	21.9 (9,9)
	PN 100	15.3 (389)	–	0.95 (24,1)	7.7 (196)	28.0 (12,7)
	PN 160	15.3 (389)	–	0.95 (24,1)	7.7 (196)	28.0 (12,7)
	JIS 10K/20K	14.0 (356)	–	0.95 (24,1)	7.7 (196)	22.3 (10,1)
	JIS 40K	15.4 (391)	–	0.95 (24,1)	7.7 (196)	26.08 (11,8)
2 (50)	Class 150	11.3 (287)	11.8 (300)	1.49 (37,8)	8.1 (206)	27.0 (12,3)
	Class 300	11.8 (300)	12.3 (312)	1.49 (37,8)	8.1 (206)	32.4 (14,7)
	Class 600	12.4 (315)	12.4 (315)	1.49 (37,8)	8.1 (206)	34.8 (15,8)
	Class 900	13.4 (340)	13.4 (340)	1.49 (37,8)	8.1 (206)	45.9 (20,8)
	Class 1500	13.4 (340)	13.4 (340)	1.49 (37,8)	8.1 (206)	45.9 (20,8)
	PN 16/40	9.9 (251)	–	1.49 (37,8)	8.1 (206)	28.7 (13,0)
2½ (60)	PN 100	11.3 (287)	–	1.49 (37,8)	8.1 (206)	37.4 (17,0)
	PN 160	11.4 (290)	–	1.49 (37,8)	8.1 (206)	38.8 (17,6)
	JIS 10K/20K	10.3 (262)	–	1.49 (37,8)	8.1 (206)	27.9 (12,6)
	JIS 40K	11.5 (292)	–	1.49 (37,8)	8.1 (206)	34.9 (15,8)
	Class 150	13.0 (330)	13.5 (343)	1.92 (48,8)	8.5 (216)	31.9 (14,5)
	Class 300	13.5 (343)	14.0 (356)	1.92 (48,8)	8.5 (216)	35.9 (16,3)
3 (75)	Class 600	14.3 (363)	14.3 (363)	1.92 (48,8)	8.5 (216)	39.4 (17,9)
	Class 900	16.5 (419)	16.7 (424)	1.92 (48,8)	8.5 (216)	69.1 (31,4)
	Class 1500	15.6 (396)	15.7 (399)	1.67 (42,4)	8.5 (216)	72.4 (32,9)
	PN 16/40	11.8 (300)	–	1.92 (48,8)	8.5 (216)	32.8 (14,9)
	PN 63/64	12.9 (328)	–	1.92 (48,8)	8.5 (216)	40.4 (18,3)
	PN 100	13.4 (340)	–	1.92 (48,8)	8.5 (216)	46.2 (20,9)
3½ (90)	PN 160	13.9 (353)	–	1.92 (48,8)	8.5 (216)	48.4 (21,9)
	JIS 10K	11.5 (292)	–	1.92 (48,8)	8.5 (216)	29.1 (13,2)
	JIS 20K	12.0 (305)	–	1.92 (48,8)	8.5 (216)	30.0 (13,6)
	JIS 40K	13.6 (345)	–	1.92 (48,8)	8.5 (216)	38.1 (13,6)

Table 27. Vortex Dual-Sensor Style Flowmeter (1/2- through 3-in./15 mm through 80 mm Line Sizes)

3 (80)	Class 150	14.3 (363)	14.8 (376)	2.87 (72,9)	9.1 (231)	50.6 (23,0)
	Class 300	15.0 (381)	15.7 (399)	2.87 (72,9)	9.1 (231)	59.9 (27,2)
	Class 600	15.8 (401)	15.9 (404)	2.87 (72,9)	9.1 (231)	65.9 (29,9)
	Class 900	17.3 (439)	17.4 (442)	2.87 (72,9)	9.1 (231)	88.4 (40,8)
	Class 1500	18.5 (470)	18.7 (475)	2.60 (66,0)	9.1 (232)	123.8 (56,2)
	PN 16/40	13.4 (340)	–	2.87 (72,9)	9.1 (231)	50.0 (22,7)
	PN 63/64	14.5 (367)	–	2.87 (72,9)	9.1 (231)	58.7 (26,6)
	PN 100	14.9 (378)	–	2.87 (72,9)	9.1 (231)	68.0 (30,9)
	PN 160	15.6 (396)	–	2.87 (72,9)	9.1 (231)	73.4 (33,3)
	JIS 10K	12.3 (312)	–	2.87 (72,9)	9.1 (231)	41.4 (18,8)
	JIS 20K	13.7 (348)	–	2.87 (72,9)	9.1 (231)	48.8 (22,1)
	JIS 40K	15.5 (394)	–	2.87 (72,9)	9.1 (231)	63.7 (28,9)

Table 28. Vortex Dual-Sensor Style Flowmeter (4- through 12-in./100 mm through 300 mm Line Sizes)

Nominal size inch (mm)	Flange rating	Face-to-face A inch (mm)	A ANSI RTJ inch (mm)	Diameter B inch (mm)	C inch (mm)	Weight lb (kg)	
4 (100)	Class 150	15.2 (386)	15.7 (399)	3.79 (96,3)	9.6 (244)	69.7 (31,6)	
	Class 300	16.0 (406)	16.6 (422)	3.79 (96,3)	9.6 (244)	88.9 (40,8)	
	Class 600	17.7 (450)	17.9 (454)	3.79 (96,3)	9.6 (244)	116 (52,5)	
	Class 900	18.7 (475)	18.9 (480)	3.79 (96,3)	9.6 (244)	139 (63,1)	
	Class 1500	20.0 (509)	20.2 (512)	3.40 (86,4)	9.6 (244)	184 (83,3)	
	PN 16	13.3 (338)	–	3.79 (96,3)	9.6 (244)	58.7 (26,6)	
	PN 40	14.4 (366)	–	3.79 (96,3)	9.6 (244)	67.8 (30,8)	
	PN 63/64	15.4 (391)	–	3.79 (96,3)	9.6 (244)	80.8 (36,7)	
	PN 100	16.3 (414)	–	3.79 (96,3)	9.6 (244)	97.2 (44,1)	
	PN 160	17.1 (434)	–	3.79 (96,3)	9.6 (244)	104 (47,4)	
	JIS 10K	13.6 (345)	–	3.79 (96,3)	9.6 (244)	55.8 (25,3)	
	JIS 20K	13.6 (345)	–	3.79 (96,3)	9.6 (244)	63.8 (28,9)	
	JIS 40K	16.8 (427)	–	3.79 (96,3)	9.6 (244)	94.2 (42,7)	
	6 (150)	Class 150	11.6 (295)	12.1 (307)	5.7 (144,8)	10.8 (274)	85 (39)
		Class 300	12.3 (312)	13.0 (330)	5.7 (144,8)	10.8 (274)	124 (57)
Class 600		14.3 (363)	14.4 (366)	5.7 (144,8)	10.8 (274)	191 (87)	
Class 900		16.1 (409)	16.2 (411)	5.14 (130,6)	10.8 (274)	282 (128)	
Class 1500		18.6 (472)	18.8 (478)	5.14 (130,6)	10.8 (274)	380 (173)	
PN 16		8.9 (226)	–	5.7 (144,8)	10.8 (274)	70 (32)	
PN 40		10.5 (267)	–	5.7 (144,8)	10.8 (274)	90 (41)	
PN 63/64		12.1 (307)	–	5.7 (144,8)	10.8 (274)	134 (61)	
PN 100		13.6 (345)	–	5.7 (144,8)	10.8 (274)	164 (75)	
JIS 10K		10.6 (269)	–	5.7 (144,8)	10.8 (274)	74 (34)	
JIS 20K		10.6 (269)	–	5.7 (144,8)	10.8 (274)	92 (42)	
JIS 40K		14.2 (361)	–	5.7 (144,8)	10.8 (274)	170 (77)	

Table 28. Vortex Dual-Sensor Style Flowmeter (4- through 12-in./100 mm through 300 mm Line Sizes)

8 (200)	Class 150	13.5 (343)	14.0 (356)	7.55 (191,8)	11.7 (297)	146 (66)
	Class 300	14.3 (363)	14.9 (378)	7.55 (191,8)	11.7 (297)	203 (92)
	Class 600	16.5 (419)	16.7 (424)	7.55 (191,8)	11.7 (297)	303 (138)
	Class 900	18.8 (478)	18.9 (480)	6.62 (168,1)	11.7 (297)	484 (220)
	Class 1500	22.8 (580)	23.2 (589)	6.62 (168,1)	11.7 (297)	657 (299)
	PN 10	10.4 (264)	-	7.55 (191,8)	11.7 (297)	115 (52)
	PN 16	10.4 (264)	-	7.55 (191,8)	11.7 (297)	114 (52)
	PN 25	11.8 (300)	-	7.55 (191,8)	11.7 (297)	142 (65)
	PN 40	12.5 (318)	-	7.55 (191,8)	11.7 (297)	161 (73)
	PN 63/64	14.2 (361)	-	7.55 (191,8)	11.7 (297)	221 (101)
	PN 100	15.8 (401)	-	7.55 (191,8)	11.7 (297)	287 (130)
	JIS 10K	12.2 (310)	-	7.55 (191,8)	11.7 (297)	114 (52)
	JIS 20K	12.2 (310)	-	7.55 (191,8)	11.7 (297)	139 (63)
	JIS 40K	16.5 (419)	-	7.55 (191,8)	11.7 (297)	260 (118)
10 (250)	Class 150	14.5 (368)	15.0 (381)	9.56 (243)	12.8 (325)	202 (91,6)
	Class 300	15.8 (401)	16.4 (417)	9.56 (243)	12.8 (325)	290 (132)
	Class 600	19.0 (483)	19.2 (488)	9.56 (243)	12.8 (325)	482 (219)
	PN 10	11.9 (302)	-	9.56 (243)	12.8 (325)	161 (73,2)
	PN 16	12.0 (305)	-	9.56 (243)	12.8 (325)	166 (75,4)
	PN 25	13.5 (343)	-	9.56 (243)	12.8 (325)	203 (92,0)
	PN 40	14.8 (376)	-	9.56 (243)	12.8 (325)	251 (114)
	PN 63/64	16.4 (417)	-	9.56 (243)	12.8 (325)	312 (142)
	PN 100	18.9 (480)	-	9.56 (243)	12.8 (325)	450 (204)
	JIS 10K	14.5 (368)	-	9.56 (243)	12.8 (325)	179 (81,1)
	JIS 20K	14.5 (368)	-	9.56 (243)	12.8 (325)	226 (103)
	JIS 40K	18.1 (460)	-	9.56 (243)	12.8 (325)	383 (174)
12 (300)	Class 150	16.8 (427)	17.3 (439)	11.38 (289)	13.7 (348)	302 (137)
	Class 300	18.0 (457)	18.7 (475)	11.38 (289)	13.7 (348)	420 (191)
	Class 600	20.5 (521)	20.7 (526)	11.38 (289)	13.7 (348)	600 (272)
	PN 10	13.1 (331)	-	11.38 (289)	13.7 (348)	208 (94,5)
	PN 16	13.9 (353)	-	11.38 (289)	13.7 (348)	229 (104)
	PN 25	15.0 (381)	-	11.38 (289)	13.7 (348)	274 (124)
	PN 40	16.8 (427)	-	11.38 (289)	13.7 (348)	352 (160)
	PN 63/64	18.8 (478)	-	11.38 (289)	13.7 (348)	435 (198)
	PN 100	21.2 (538)	-	11.38 (289)	13.7 (348)	648 (294)
	JIS 10K	15.7 (399)	-	11.38 (289)	13.7 (348)	227 (103)
	JIS 20K	15.7 (399)	-	11.38 (289)	13.7 (348)	288 (131)
	JIS 40K	19.6 (498)	-	11.38 (289)	13.7 (348)	498 (226)

Figure 7. Vortex Weld-End Style Flowmeter (1/2- through 4-in. [15 mm – 100 mm] Line Sizes)

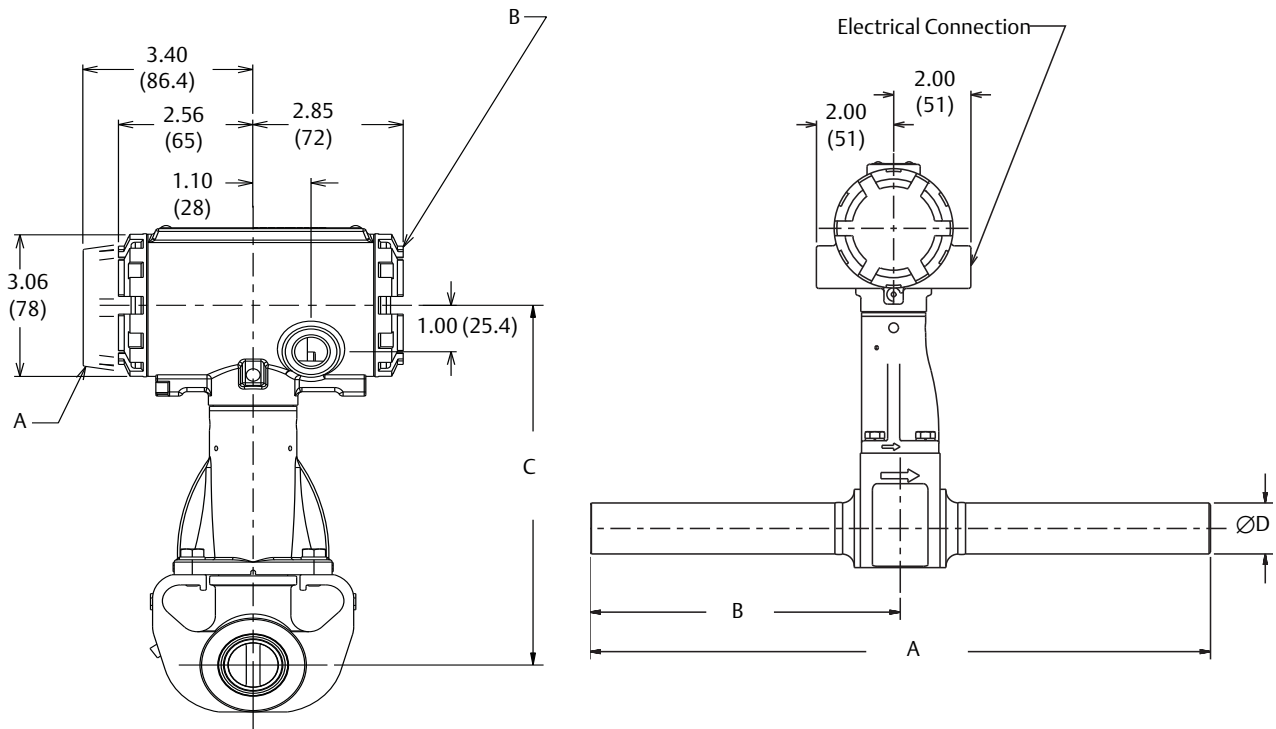

A. Display Option
 B. Terminal Cover

Table 29. Vortex Weld-End Style Flowmeter (1/2- through 4-in. [15 mm - 100 mm] Line Sizes)

Nominal size in. (mm)	A in. (mm)	B in. (mm)	C ± 0.20 in. (5.1 mm)	Diameter D ± 0.031 in. (0.79 mm)
0.5	16.0 (406)	8.0 (203)	7.63 (194)	.840 (21.34)
1	16.0 (406)	8.0 (203)	7.74 (197)	1.315 (33.40)
1.5	16.0 (406)	8.0 (203)	8.14 (207)	1.900 (48.26)
2	16.0 (406)	8.0 (203)	8.49 (216)	2.375 (60.33)
3	16.0 (406)	8.0 (203)	9.05 (230)	3.500 (88.90)
4	16.0 (406)	8.0 (203)	9.60 (244)	4.500 (114.30)

Figure 8. Remote Mount Transmitters

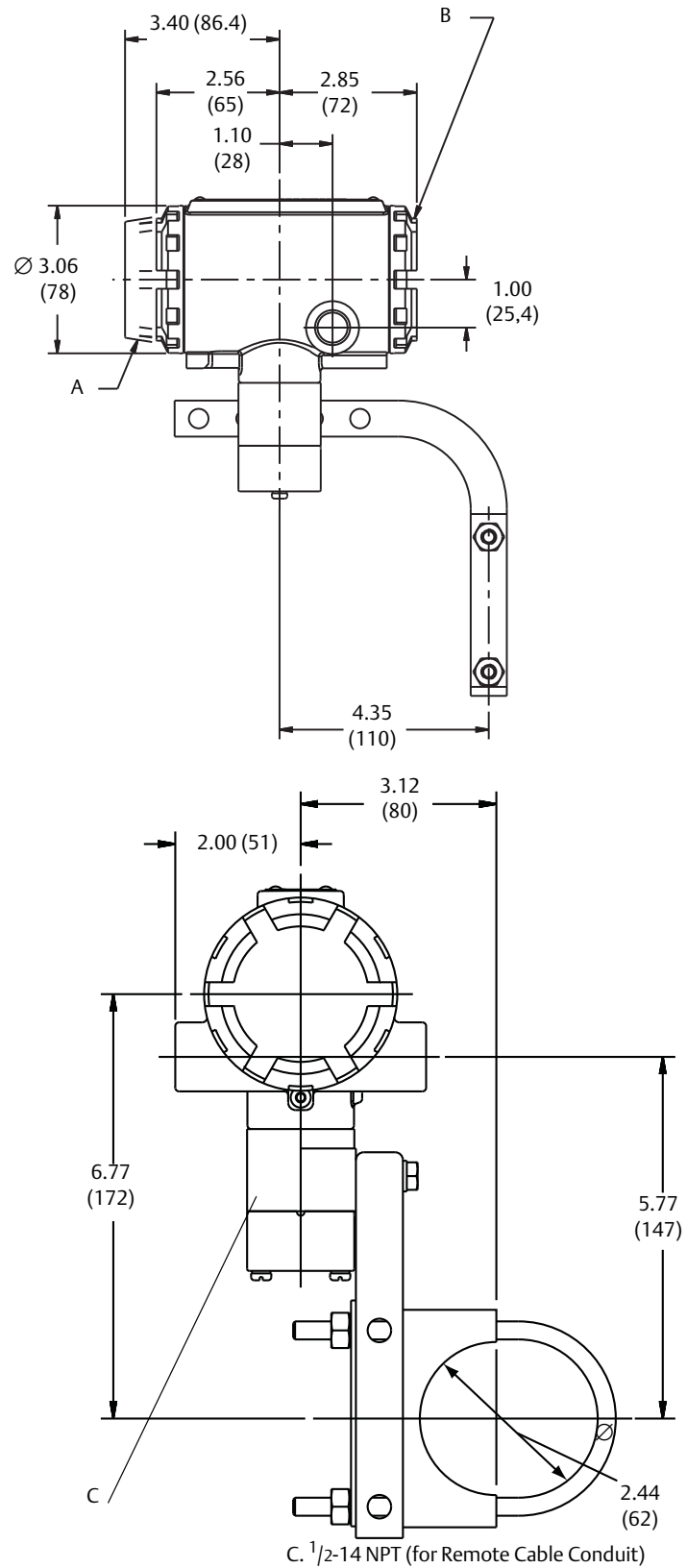

Note
Consult factory for SST installation.
Dimensions are in inches (millimeters).

A. Display Option
B. Terminal Cover

C. 1/2-14 NPT (for Remote Cable Conduit)

Figure 9. Remote Mount Wafer-Style Flowmeters ($1\frac{1}{2}$ - through 8-in./15 mm through 200 mm Line Sizes)

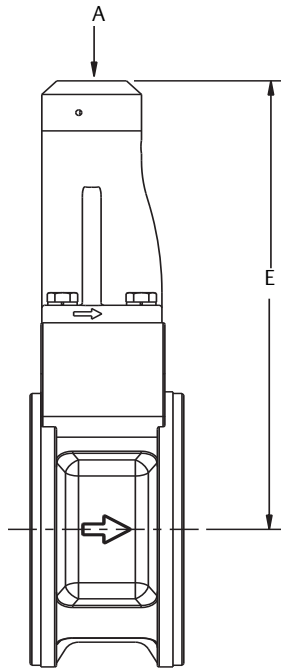

A. $1\frac{1}{2}$ -14 NPT (for Remote Cable Conduit)

Table 30. Rosemount 8800D Wafer-Style Meter

Nominal size inch (mm)	E Wafer style inch (mm)
$\frac{1}{2}$ (15)	6.3 (160)
1 (25)	6.5 (165)
$1\frac{1}{2}$ (40)	6.7 (191)
2 (50)	7.5 (191)
3 (80)	8.3 (211)
4 (100)	9.2 (234)
6 (150)	9.5 (241)
8 (200)	10.4 (264)

Figure 10. Flanged-and Dual Sensor Flanged-Style Remote Mount Flowmeters (1/2- through 12-inch/15 mm through 300 mm Line Sizes)

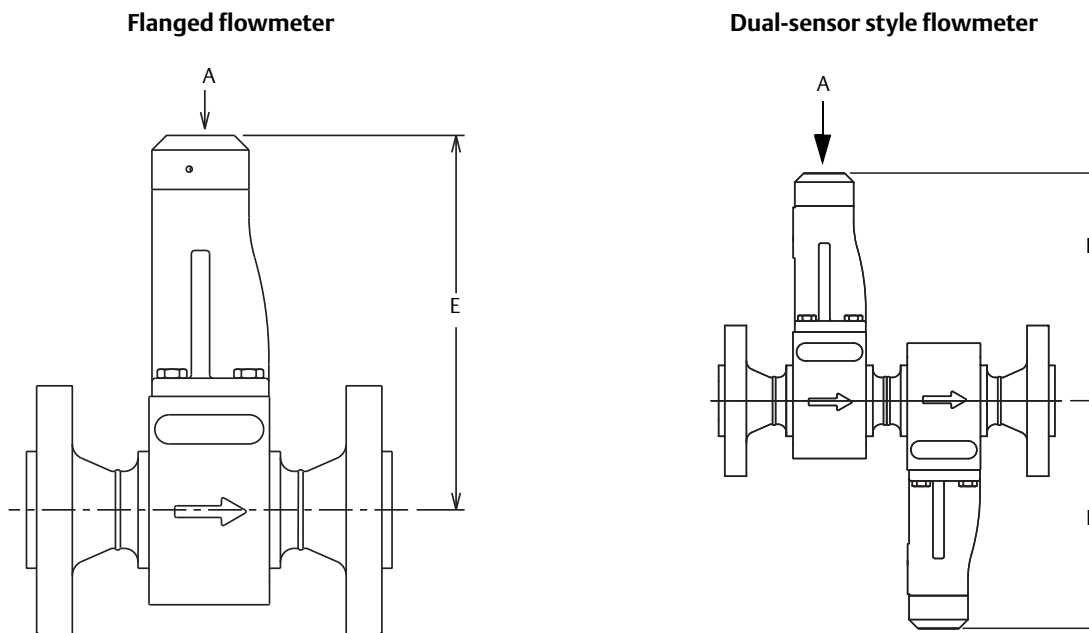

A. 1/2-14 NPT (for Remote Cable Conduit)

Table 31. Remote Mount, Flanged-and Dual Sensor Flowmeter Dimensions

Nominal size inch (mm)	E Flange style inch (mm)
1/2 (15)	6.4 (162)
1 (25)	6.5 (165)
1 1/2 (40)	6.8 (173)
2 (50)	7.2 (183)
3 (80)	7.8 (198)
4 (100)	8.3 (211)
6 (150)	9.5 (241)
8 (200)	10.4 (264)
10 (250)	11.4 (290)
12 (300)	12.3 (313)

Global Headquarters

Emerson Process Management

6021 Innovation Blvd.
Shakopee, MN 55379, USA
+1 800 522 6277 or +1 303 527 5200
+1 303 530 8459
Flow.Support@Emerson.com

North America Regional Office

Emerson Process Management

7070 Winchester Circle
Boulder, CO 80301 USA
+1 800 522 6277 or +1 303 527 5200
+1 303 530 8459
Flow.Support@Emerson.com

Latin America Regional Office

Emerson Process Management

Multipark Office Center
Turrubares Building, 3rd & 4th floor
Guachipelin de Escazu, Costa Rica
+1 506 2505-6962
+1 954 846 5121
Flow.Support@Emerson.com

Europe Regional Office

Emerson Process Management Flow B.V.

Neonstraat 1
6718 WX Ede
The Netherlands
+31 (0) 318 495555
+31 (0) 318 495556
Flow.Support@Emerson.com

Asia Pacific Regional Office

Emerson Process Management Asia Pacific Pte Ltd

1 Pandan Crescent
Singapore 128461
+65 6777 8211
+65 6777 0947
APflow.support@emerson.com

Middle East and Africa Regional Office

Emerson Process Management

Emerson FZE P.O. Box 17033,
Jebel Ali Free Zone - South 2
Dubai, United Arab Emirates
+971 4 8118100
+971 4 8865465
FlowTechnicalSupport@emerson.com

Standard Terms and Conditions of Sale can be found at
www.rosemount.com/terms_of_sale.

The Emerson logo is a trade mark and service mark of Emerson Electric Co. Rosemount, and the Rosemount logotype are trademarks of Rosemount Inc. AMS is a registered trademarks of Rosemount Inc.

CriticalProcess, DeltaV, MultiVariable, and Reducer Vortex are trademarks of Rosemount Inc.

PlantWeb is a registered trademark of one of the Emerson Process Management group of companies.

HART and FOUNDATION Fieldbus are registered trademarks of the FieldComm Group.

eufofast and minifast are registered trademarks of TURCK.

NACE is a registered trademark of NACE International.

All other marks are the property of their respective owners.

© 2015 Rosemount Inc. All rights reserved.